



PTS-2 forecourt controller

TECHNICAL GUIDE

Review date: 17 April, 2026

CONTENT

REVISION HISTORY	6
PURPOSE OF THE DOCUMENT	7
APPOINTMENT	8
TECHNICAL CHARACTERISTICS	9
General specification	9
Peripheral hardware	9
Communication	9
Configuration	9
COMPLETE SET	10
SUPPORTED BRANDS OF FUEL DISPENSERS AND REGISTER METERS*	11
SUPPORTED BRANDS OF ATG SYSTEMS AND PROBES*	12
SUPPORTED BRANDS OF PRICE BOARDS*	12
SUPPORTED BRANDS OF READERS*	12
BOARD CONNECTORS, INTERFACES AND DIMENSIONS	13
COMMUNICATION PORTS	14
CONFIGURATION DIP-switch	15
SD FLASH CARD	16
DEBUG PORT	17
CONNECTION TO CONTROL SYSTEMS USING ETHERNET INTERFACE	17
CONNECTION TO CONTROL SYSTEMS USING RS-232 INTERFACE	18
WEB-SERVER	19
General information	19
Connection to web-server	20
Device information page	21
Configuration page	23
Pumps control page	42
Tanks monitoring page	44
Reporting page	46
Logging	56
Self-diagnostics page	58
Firmware update page	60
BUILT-IN PUMPS SIMULATOR	62
BUILT-IN PROBES SIMULATOR	64
FILES STORED ON SD FLASH DISK	66
Example of PUMPTRN.CSV file:	66
Example of TANKMSR.CSV file:	66
Example of TANKDLV.CSV file:	67
Example of GPSRECS.CSV file:	67
Example of ALERTS.CSV file:	67
Example of TAGS.CSV file:	67
Example of tank calibration chart file NNCALIB.CSV (NN – tank number):	68
CONFIGURATION FILE pts_config_XX.js	71
GPS MODULE	74
RESET OF CONFIGURATION	76
CONNECTION TO DISPENSERS	77
CONNECTION TO ATG SYSTEMS AND PROBES	83
TANKS AUTOMATIC CALIBRATION	89

CONNECTION TO PRICE BOARDS	94
CONNECTION TO RFID READERS AND AVI SYSTEMS.....	98
WIRELESS COMMUNICATION	105
AUTOMATIC OPERATION ON SITE	106
COMMUNICATION TO REMOTE SERVER.....	109
Resolving possible problems in communication to a remote server	115
Test of communication with a remote server	116
FUEL DELIVERY TRUCKS CONTROL AND GPS TRACKING	118
CONVERSION BETWEEN PUMPS COMMUNICATION PROTOCOLS	119
CONVERSION BETWEEN PROBES COMMUNICATION PROTOCOLS	120
MONITORING OVER PETROL STATION ACTIVITY AND ALERTS	121
INSTALLATION REQUIREMENTS	122
PTS-2 CONTROLLER SOFTWARE DEVELOPMENT KIT (SDK).....	124
PTS-2 controller SDK appointment.....	124
PTS-2 controller SDK structure	125
PTS-2 controller SDK technical features	125
Specification	125
PTS-2 controller SDK connections scheme.....	126
UniPump pumps software simulator.....	127
Purpose.....	127
Main view	127
Configuration.....	128
UniProbe ATG probes software simulator	130
Purpose.....	130
Main view	130
Configuration.....	131
.NET Core API and open-source application.....	133
Step-by-step configuration of the PTS-2 controller SDK	134
Purpose.....	134
Step 1. Assembling PTS-2 controller SDK cabling and connection to computer	134
Step 2. Starting of PTS-2 controller web-server	135
Step 3. Configuration of pump ports.....	135
Step 4. Configuration of probes ports	136
Step 5. Configuration of PTS-2 controller parameters	137
Step 6. Configuration of pumps parameters	138
Step 7. Configuration of probe parameters	139
Step 8. Configuration of fuel grades.....	140
Step 9. Configuration of tanks.....	141
Step 10. Configuration of pump nozzles	142
Step 11. Configuration of pumps software simulator	143
Step 12. Configuration of ATG probes software simulator	144
Step 13. Control over pumps and ATG probes	145
Step 14. Saving of pumps sales and tank measurements to database with reports generation	147
Step 15. Reading of pump totals automatically in end of filling	149
Step 16. Automatic pumps authorization on nozzle up	152
Step 17. Testing of operation with PTS-2 controller from Postman utility	152
EXAMPLES OF CONNECTION TO FUEL DISPENSERS	153
Gilbarco dispenser connection scheme (2-wire current loop interface)	154
Gilbarco dispenser connection scheme (RS-485 interface).....	157

Wayne Dresser dispenser connection scheme (RS-485 interface)	158
Wayne Dresser dispenser connection scheme (current loop interface).....	159
TATSUNO (Japan) dispenser connection scheme.....	160
TATSUNO Europe (former Benc) dispenser connection scheme	161
Tokheim dispenser connection scheme (3-wire current loop interface).....	162
Tokheim dispenser connection scheme (RS-485 interface)	165
Tokheim India dispenser connection scheme	167
Nuovo Pignone dispenser connection scheme (RS-485 interface)	168
Nuovo Pignone dispenser connection scheme (4-wire current loop interface)	169
Logitron dispenser connection scheme (3-wire current loop interface)	170
Bennett dispenser connection scheme (RS-485 interface)	171
Bennett dispenser connection scheme (2-wire current loop interface)	172
Batchen Email dispenser connection scheme	173
Scheidt & Bachmann T20 dispenser connection scheme.....	174
Neotec dispenser connection scheme	175
Coptron dispenser connection scheme.....	176
Midco dispenser connection scheme.....	177
Petrotec dispenser connection scheme	178
Galileo dispenser connection scheme.....	179
Prowalco dispenser connection scheme	180
Emgaz Dragon / Fornovo LPG dispenser with EsiWelma pumphed connection scheme.....	181
Maser dispenser connection scheme.....	182
Petposan-S4 / Meksan-S4 / Europump-S4 / Yenen dispensers connection scheme	183
Yenen dispensers connection scheme	184
Petposan-Beta / Europump-Beta dispensers connection scheme.....	185
EuroPump dispenser connection scheme	186
Mekser dispenser connection scheme	187
Fuelsis dispenser connection scheme	188
Mepsan Unimep dispenser connection scheme	189
Meksan / Wayne SU86 dispenser connection scheme	190
Baransay dispenser connection scheme	191
Durulsan dispenser connection scheme.....	192
2A LPG dispenser connection scheme.....	193
Falcon dispenser connection scheme.....	194
Tiger dispenser connection scheme	195
Korea EnE (LG EnE) dispenser connection scheme	196
Dong Hwa Prime dispenser connection scheme	197
Gallagher (PEC) dispenser connection scheme	198
Compac dispenser connection scheme	199
Safe dispenser connection scheme	200
MS Gas dispenser connection scheme	201
Shibata dispenser connection scheme	202
Aspro Develco dispenser connection scheme.....	203
HongYang dispenser connection scheme.....	204
Lanfeng dispenser connection scheme	206
Sanki dispenser connection scheme	207
Datian Machines dispenser connection scheme	209
Eaglestar dispenser connection scheme	210
Blue Sky dispenser connection scheme.....	211

Censtar dispenser connection scheme.....	212
Knipflow dispenser connection scheme.....	213
Changlong dispenser connection scheme.....	214
Zcheng Genuine Machines dispenser connection scheme.....	215
Bailong dispenser connection scheme.....	216
Ecotec dispenser connection scheme.....	217
Topaz dispenser connection scheme.....	218
Shelf dispenser connection scheme.....	219
UniCon dispenser connection scheme.....	220
Mechanical dispensers connection scheme.....	221
EXAMPLES OF CONNECTION TO ATG SYSTEMS.....	222
Gilbarco Veeder Root TLS consoles connection scheme.....	222
Start Italiana console connection scheme.....	222
Start Italiana wired probes connection scheme.....	223
Start Italiana wireless probes connection scheme.....	223
Alisonic wired probes connection scheme.....	224
Alisonic wireless probes connection scheme.....	224
Struna ATG system connection scheme.....	225
OPW Site Sentinel ATG system connection scheme.....	225
Colibri ATG system connection scheme.....	226
Fafnir ATG system connection scheme.....	226
Hectronic ATG probes connection scheme.....	227
Vega radar level meters.....	227
Windbell magnetostrictive probes connection scheme.....	228
North Falcon wired probes connection scheme.....	229
North Falcon wireless probes connection scheme.....	229
EXAMPLES OF CONNECTION TO PRICE POLES.....	230
PWM price poles connection scheme.....	230
BEVER Innovations price signs connection scheme.....	230
EXAMPLES OF CONNECTION TO READERS AND AVI SYSTEMS.....	231
VRD-485 RFID readers connection scheme.....	231
MINGTE AVI system controller connection scheme.....	231
ORDER INFORMATION.....	232

REVISION HISTORY

REV	DATE	BY	SECTIONS	DESCRIPTION
R01	2019.06.07	Evgeniy Vasyliiev	All	First release of PTS-2 board revision
R02	2020.03.03	Evgeniy Vasyliiev	All sections reviewed and added	Added new sections for upload of data to remote server and tanks calibration charts, all existing sections reviewed.
R03	2020.10.21	Evgeniy Vasyliiev	Configuration sections updates	Updates related to new configuration options added.
R04	2021.03.23	Evgeniy Vasyliiev	Configuration sections updates	Updates related to new configuration options added.
R05	2021.07.09	Evgeniy Vasyliiev	All	Revised due to lots of changes in development made.
R06	2021.12.12	Evgeniy Vasyliiev	Updated firmware version for support of price-boards and RFID readers	Added support for readers and price-boards, web server screenshots updated, GPS module description updated.
R07	2022.02.10	Evgeniy Vasyliiev	Reviewed the document structure, added communication to remote server chapter, some new pumps connection schemes	Added support for WebSocket protocol, added some new pumps connection schemes,
R08	2022.09.27	Evgeniy Vasyliiev	Reviewed the document structure, added communication to remote server chapter, some new pumps connection schemes	Added support for in-tank deliveries, alerts and status storage and upload to a remote server, added some new pumps connection schemes.
R09	2023.02.24	Evgeniy Vasyliiev	PTS-2 controller SDK	PTS-2 controller SDK structure updated
R10	2023.04.17	Evgeniy Vasyliiev	PTS-2 controller new board modifications	PTS-2 controller new PCB board, PTS-2 PRO controller PCB board
R11	2023.04.25	Evgeniy Vasyliiev	PTS-2 controller new board modifications	Added description of the PTS-2 controller configuration for various applications
R12	2026.04.06	Evgeniy Vasyliiev	Tank automatic calibration section	Rewritten a section related to tank automatic calibration

PURPOSE OF THE DOCUMENT

This Technical Guide is intended for studying of PTS-2 forecourt controller for petrol stations. It contains basic information regarding its

- technical characteristics
- supported communication protocols of fuel dispensers, ATG systems, price boards, readers
- board interfaces and connectors
- configuration
- description, configuration and connection of PTS-2 controller software development kit (SDK)
- schemes of connection to various fuel dispensers, ATG systems, price-boards and readers

Information regarding connection to specific forecourt equipment (fuel dispensers, ATG systems, price-boards and readers) and correspondent configuration of PTS-2 controller can be received upon request to Technotrade LLC company.

Due to a reason that PTS-2 controller firmware is constantly being developed in direction of improvement of its possibilities, changes are possible in final version, which are not described in given Technical Guide.

During the system development process given Technical Guide is also expanded and updated and new chapters are added. The latest version of this Technical Guide can be downloaded from the PTS-2 controller web-page: <http://www.technotrade.ua/pts2-forecourt-controller.html>.

Technotrade LLC hereby permits reproduction of this document as may be required by any of the customers or OEMs wishing to use it.

This document has been carefully prepared and is believed to be accurate. However, Technotrade LLC, its employees and its agents do not assume responsibility for its use either directly or indirectly. Technotrade LLC shall not be liable for technical or editorial errors or omissions which may appear in this document. Technotrade LLC reserves a right to make changes to this document at any time without notice. Prospective users of this document should contact Technotrade LLC at the time they wish to use PTS-2 forecourt controller together with their products to become aware of any updates that may apply.

In case if you find any mistakes, omissions in this document or have any suggestions on improvements to this document, please feel free to e-mail them to our support mailbox: support@technotrade.ua. We will be grateful to you for this valuable information.

All technical questions regarding the PTS-2 forecourt controller are welcome to be asked on support mailbox: support@technotrade.ua. Our support team will be glad to help you.

Also, you can call to us or visit us on:

Technotrade LLC

Ukraine, 04082 Kiev, Priorska str. 10, office 1

Tel: +38 044 502 46 55, +38 044 502 46 77

Web: www.technotrade.ua

Mail: mail@technotrade.ua

APPOINTMENT

PTS-2 forecourt controller is a powerful modern forecourt controller for provision of control over:

- petroleum, LPG and CNG dispensers
- automatic tank gauge systems and probes
- price signs
- RFID readers and AVI systems

Its dimensions are extremely small with a size of a credit card, which makes its suitable for installation inside any third-party hardware.

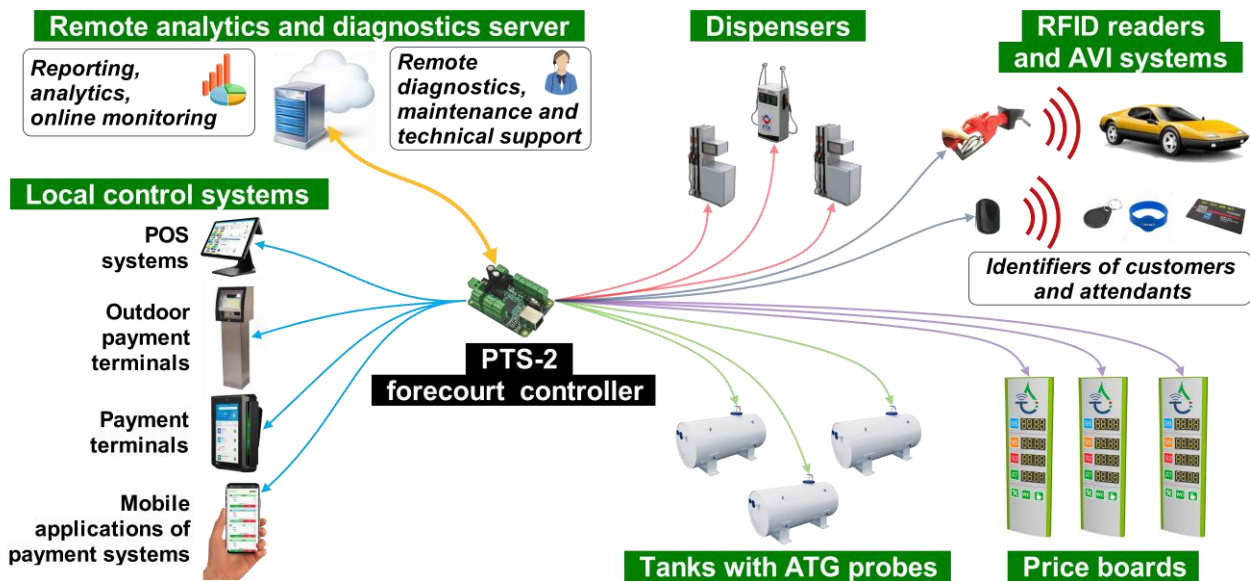

PTS-2 controller knows communication protocols of a great variety of dispensers, ATG systems and probes, price boards, RFID readers and AVI systems allowing to control over any of them in a common way regardless of the brand or communication protocol used, so using the PTS-2 controller any management system (POS system, OPT, mobile application) can use a common way for provision of control over any supported brands in the same way and should not matter what are the brands of the equipment installed because the PTS-2 controller undertakes all communication with equipment using their native communication protocols and takes into account all the peculiarities. This completely simplifies work for a developer of control system: by having implemented communication protocol of the PTS-2 controller you gain ability to provide control over any of dispensers, ATG systems and probes, price boards and readers supported by PTS-2 controller in a common way, so the time required for development of the POS system, cash register, payment terminal or mobile applications is significantly reduced.

PTS-2 controller leads internal database for pumps sales, tanks measurements, in-tank deliveries, alerts, GPS records, fuel attendants' and customers' tags. It allows to generate reports using a web browser and also can automatically upload all the registered records to any remote cloud server, allowing to easily remotely receive all detailed reports real-time from the petrol stations, petroleum depots and fuel delivery trucks.

Dimensions of the PTS-2 controller are extremely small with a size of a credit card, which makes its suitable for installation inside any third-party hardware.

TECHNICAL CHARACTERISTICS

General specification

##	PARAMETER	VALUE
1	Power supply voltage	12 V DC
2	Maximal current consumption	700 mA max
3	Temperature range	-40°C ... +60°C
4	Weight	200 g
5	Overall dimensions	85 x 58 x 30 mm

Peripheral hardware

##	PARAMETER	VALUE
1	Battery type	CR2032 3V DC
2	SD card	microSD, class 10

Communication

##	PARAMETER	VALUE
1	Input protocol for Ethernet port	jsonPTS protocol: JSON-based communication protocol (proprietary of Technotrade LLC)
2	Input protocol for PC port (RS-232 interface)	UniPump protocol: binary communication protocol (proprietary of Technotrade LLC)
3	Security	SSL/TLS 1.2

Configuration

##	PARAMETER	VALUE
1	Quantity of pump ports	4
2	Quantity of pumps supported	up to 120
3	Quantity of probe ports	3
4	Quantity of probes supported	up to 20
5	Quantity of fuel grades	up to 20
6	Quantity of tanks	up to 20
7	Quantity of users	up to 10
8	Quantity of pump transaction records	100000
9	Quantity of tank measurements records	100000
10	Quantity of price boards supported	up to 5
11	Quantity of products per each price board	up to 10
12	Quantity of RFID readers supported	up to 120
13	Quantity of RFID tags supported	No limit
14	Internationalization (language of web interface)	English Spanish Russian Ukrainian

COMPLETE SET

There are 2 main versions of the PTS-2 controller:

- *PTS-2 controller* based on STM32F427 microcontroller
- *PTS-2 PRO controller* (advanced version) based on STM32H743/STM32H753 microcontroller

Depending on the order code (see section [Order information](#)) PTS-2 controller can be supplied either in a view of electrical board (variant of controller supply *PTS2-PCB-z* or *PTS2PRO-PCB-z*), or installed in a mounting box with cables inputs and a power switching button (variant of controller supply *PTS2-BOX-z* or *PTS2PRO-BOX-z*).



Variant of controller supply in a view of electrical board (PTS2-PCB-z or PTS2PRO-PCB-z)



Variant of controller supply installed in a metal box with cables inputs and a power switching button (variant of controller supply PTS2-BOX-z or PTS2PRO-BOX-z)

SUPPORTED BRANDS OF FUEL DISPENSERS AND REGISTER METERS*

- | | | |
|---------------------------|-----------------------------------|------------------------------|
| 1. 2A | 55. HAKO | 108. PROWALCO |
| 2. ACTRONIC | 56. HITACHI | 109. PUMP CONTROL |
| 3. ADAST (ADAMOV SYSTEMS) | 57. HONG YANG | 110. PUMPTRONICS |
| 4. AG WALKER | 58. IFSF (dispensers) | 111. REAL-TECH |
| 5. AGIRA | 59. IMW | 112. RIX |
| 6. ANGI International | 60. INTERMECH | 113. S.A.M.P.I. |
| 7. ARIEL | 61. IPT | 114. SAFE |
| 8. ASPRO | 62. JANASI | 115. SALZKOTTEN |
| 9. ASSYTECH | 63. JAPAN ENERJUMP | 116. SANKI |
| 10. ASTRON | 64. JAPAN TECH | 117. SATAM EQUALIS S |
| 11. AZT | 65. KAISAI | 118. SAVEL |
| 12. BAILONG | 66. KALVACHA | 119. SEA BIRD |
| 13. BARANSAY | 67. KIEVNIIGAZ | 120. SCHEIDT&BACHMANN |
| 14. BATCHEN | 68. KOREA ENE | 121. SHELF |
| 15. BENNETT | 69. KPG-2 | 122. SHIBATA |
| 16. BERNET | 70. KRAUS | 123. SICHUAN |
| 17. BLUE SKY | 71. KRIPFLOW | 124. SLAVUTICH |
| 18. CENSTAR | 72. KWANGSHIN | 125. SOMO PETRO |
| 19. CETIL | 73. LAFON | 126. STABILIZING |
| 20. CFT Clean Fuel | 74. LANFENG | 127. STAR |
| 21. CHANGLONG | 75. LAOXU | 128. STAR-HIGH |
| 22. COMPAC | 76. LEARED | 129. TATSUNO (JAPAN) |
| 23. COPTRON | 77. LIQUID CONTROLS | 130. TATSUNO EUROPE (BENC) |
| 24. CORITEC | 78. LG ENE | 131. TATTAN |
| 25. CZAR | 79. LOGITRON | 132. TAURUS |
| 26. DATIAN MACHINES | 80. MAIDE | 133. TEAM |
| 27. DEM G. SPYRIDES | 81. MASER | 134. TEKSER |
| 28. DEVELCO | 82. MEKSAN / WAYNE SU86 | 135. TERABAYT TEXNO SERVIS |
| 29. DIGITAL FLOW | 83. MEKSER | 136. TIGER |
| 30. DINT | 84. MEPSAN | 137. TOKHEIM |
| 31. DONG HWA PRIME | 85. MIDCO | 138. TOKHEIM INDIA |
| 32. DURULSAN | 86. MIDCOM | 139. TOKICO |
| 33. EAGLESTAR | 87. MITHRA FUELING | 140. TOMINAGA |
| 34. EASTAR | 88. MM PETRO (ZAP) | 141. TOPAZ |
| 35. ECOTEC | 89. MOTOGAZ | 142. TOTAL CONTROL SYSTEMS |
| 36. EHAD | 90. MOUNTAIN CHINA | 143. TRANSPONDER |
| 37. EKOSIS | 91. MRT | 144. TRUE TECH |
| 38. EMGAZ DRAGON | 92. MS GAS | 145. UCAR ELEKTRIC |
| 39. ENDURANCE | 93. MUXTRONICS | 146. UESTCO |
| 40. EPCO | 94. NARA | 147. UNICON-TIT |
| 41. ESIWELMA | 95. NET FUN LEADER | 148. VANZETTI |
| 42. EUROPUMP | 96. NUOVA MIGAS | 149. WAYNE DRESSER |
| 43. FALCON LPG | 97. NUOVO PIGNONE | 150. WAYNE PIGNONE |
| 44. FLOW | 98. ONSUN | 151. WELLDONE MACHINES |
| 45. FORNOVO GAS | 99. ORCA | 152. WERTCO COMPANY TEC |
| 46. FUELQUIP | 100. PEC (GALLAGHER FUEL SYSTEMS) | 153. WINTEC ENERGY |
| 47. FUELSIS | 101. PARKER | 154. YENEN |
| 48. FUREN HIGHTECH | 102. PECO | 155. ZCHENG GENUINE MACHINES |
| 49. GALILEO | 103. PEGASUS | 156. ZHEJIANG ZHISHENG RUIHE |
| 50. GASLIN | 104. PETPOSAN | 157. ZHONGSHENG |
| 51. GERKON | 105. PETROEQUIP | |
| 52. GESPASA | 106. PETROMECCANICA | |
| 53. GILBARCO | 107. PETROTEC | |
| 54. GREENFIELD | | |

* Some dispensers may demand using interface converter boards to RS-485 interface (depends on electronics of used pumphead in dispenser).

SUPPORTED BRANDS OF ATG SYSTEMS AND PROBES*

- | | | |
|--------------------------|------------------------|--------------------------------|
| 1. ACCU | 23. HONG YANG | 45. PHOENIX |
| 2. ALISONIC | 24. HUMANENTEC | 46. POKCENSER |
| 3. ANHUI QIDIAN | 25. IFSF (ATG systems) | 47. QINGDAO GUIHE |
| 4. ASSYTECH | 26. INCON | 48. RCS EPSILON |
| 5. AXIONICS | 27. JOYO | 49. RIKA |
| 6. BLUESKY | 28. JUBO | 50. SANSHEN |
| 7. CENSTAR | 29. KACISE | 51. SBEM |
| 8. DOVER | 30. KANGYU | 52. SENSOR |
| 9. DUT-E | 31. KUNLUN | 53. SINOTECH |
| 10. EAGLESTAR | 32. LABKO | 54. SKE LEVEL GAUGE |
| 11. EBW | 33. LIGO | 55. START ITALIANA |
| 12. EMERSON ROSEMOUNT | 34. MECHATRONICS | 56. STRUNA |
| 13. ENRAF | 35. MEPSAN UNIMEP | 57. TECHNOTON |
| 14. ESCORT FD | 36. METRIKEMP | 58. TENET |
| 15. FAFNIR | 37. MTS ATG SENSORS | 59. UBTECK |
| 16. FIRSTRATE | 38. ND | 60. UNIPROBE |
| 17. FRANKLIN FUELING | 39. NORTH FALCON | 61. VEGA |
| 18. GAMICOS | 40. O.L.E. | 62. VEPAMON |
| 19. GILBARCO VEEDER ROOT | 41. OKET | 63. WINDBELL |
| 20. HCKK | 42. OMNICOMM | 64. XT SENSORS |
| 21. HECTRONIC | 43. OMNTEC | 65. ZCHENG GENUINE
MACHINES |
| 22. HOLYKELL | 44. OPW | |

SUPPORTED BRANDS OF PRICE BOARDS*

- | | | |
|----------------------|-----------------------|--|
| 1. AVS | 7. HECTRONIC | 13. QSERV |
| 2. BEVER INNOVATIONS | 8. MENTALITY | 14. RGB TECHNOLOGIES |
| 3. BODET | 9. NOVYC | 15. SHENZHEN JUMING
ELECTRONICS (UMLED) |
| 4. COMSIGHT | 10. PANELES LEDS PERU | 16. TOP SCREENS |
| 5. GILBARCO | 11. PCA | 17. U-GREAT LED |
| 6. GLARE-LED | 12. PWM | |

SUPPORTED BRANDS OF READERS*

- | | | |
|------------------|--|-----------------------|
| 1. CHAFON UHF | 5. LINKSPRITE ISO-18000-6B,
ISO-18000-6C (EPC G2) | 8. OTI PETROSMART AVI |
| 2. GATEX AVI | | 9. RDR-485 |
| 3. HECTRONIC AVI | 6. LOOPTAG AVI | 10. VIOTYS AVI |
| 4. HID AVI | 7. MINGTE AVI | 11. VRD-485 |

* Communication parameters (baud rate, parity control, data and stop bits) are configured for probes, price boards and readers ports in PTS-2 controller independently from used communication protocol.

BOARD CONNECTORS, INTERFACES AND DIMENSIONS

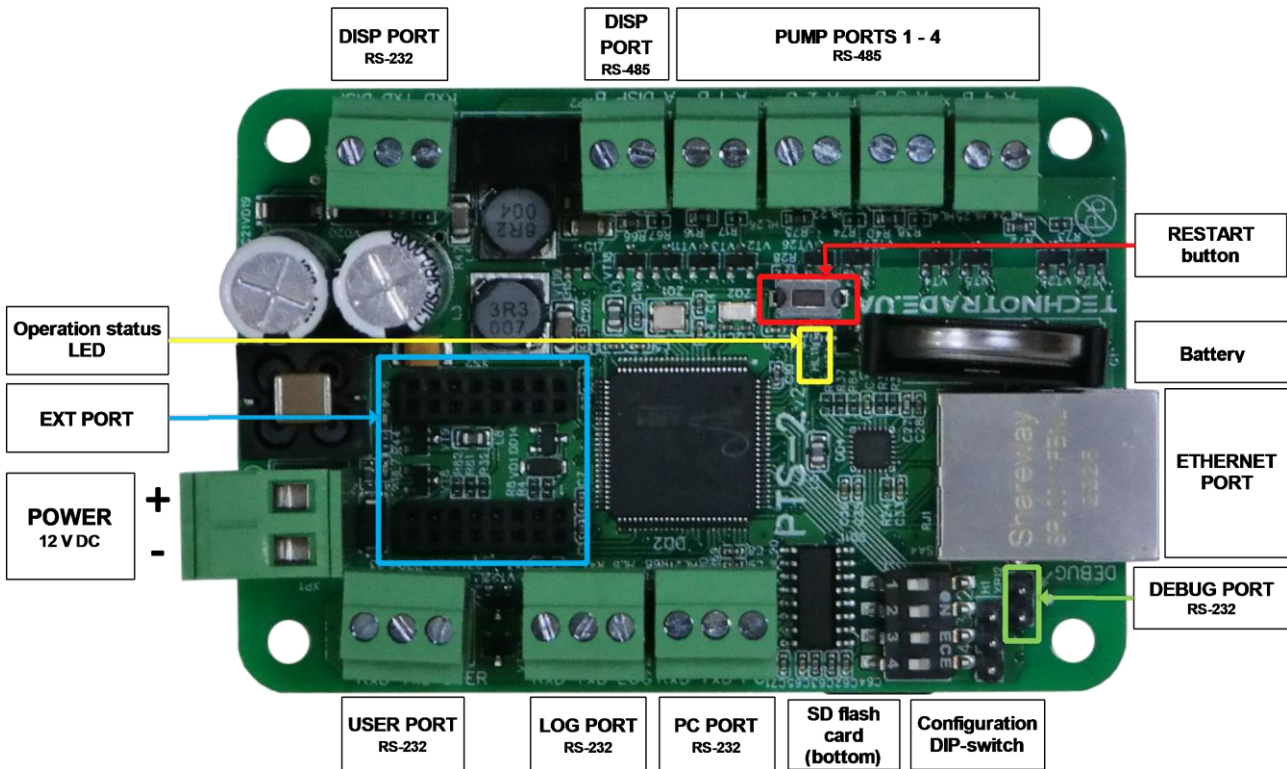

PTS-2 controller is supplied together with terminal blocks for each of the connectors for screwing of connection wires.

NOTE! Operation status LED is yellow LED, blinking during operation. In case if the system loaded correctly and there are no errors found – then the yellow LED blinks with toggling its state (on/off) each second. However, if it is blinking fast (toggling its state each 100 ms) – then there is a problem at system load and it cannot operate.

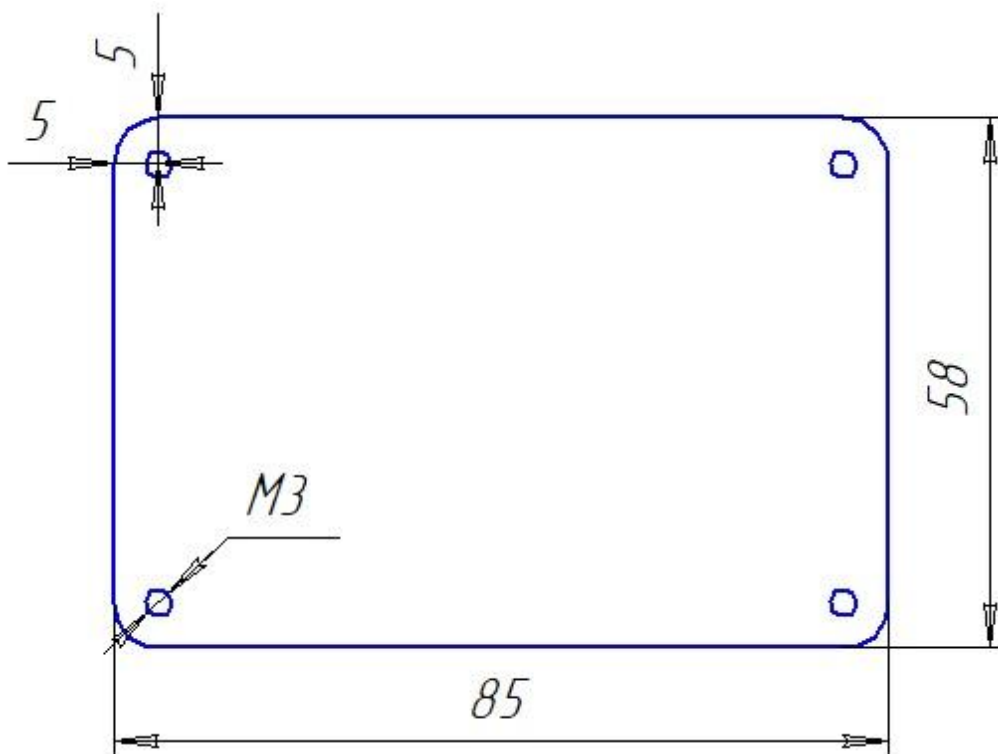

COMMUNICATION PORTS

PORT NAME	INTERFACE	APPOINTMENT
ETHERNET	Ethernet	Communication with control systems, monitoring systems, analytics systems, upload of data to remote server
PC PORT	RS-232 (3 wires: TxD, RxD, Gnd)	Connection with control system.
PUMP PORTS	Pump port 1 RS-485 (2 wires: line A, line B)	1. Connection with dispensers using configurable proprietary communication protocols. 2. Communication with control systems using popular pumps communication protocol.
	Pump port 2 RS-485 (2 wires: line A, line B)	
	Pump port 3 RS-485 (2 wires: line A, line B)	<i>It is required to use shielded cable, which shield is connected to ground on the side of connected pump.</i>
	Pump port 4 RS-485 (2 wires: line A, line B)	
PROBE PORTS	LOG port RS-232 (3 wires: TxD, RxD, Gnd)	1. Connection with ATG systems (probes) using configurable proprietary communication protocols. 2. Communication with control systems using popular probes communication protocol.
	USER port RS-232 (3 wires: TxD, RxD, Gnd)	
	DISP port (RS-485) RS-485 (2 wires: line A, line B)	
	DISP port (RS-232) RS-232 (3 wires: TxD, RxD, Gnd)	
DEBUG PORT	RS-232 (2 wires: TxD, Gnd)	Debugging of operation.
EXT PORT	RS-232 (3 wires: TxD, RxD, Gnd)	Connection to GPS receiver and other optional separate boards.

NOTE! It is strictly prohibited to connect any of the cables' shields to ports of PTS-2 controller.

Manufacturer reserves a right to bring in modifications in construction of controller for improving of its technical and functional characteristics, so supplied version of controller may differ from described in given technical guide.

WARNING! This is a class A product. In a domestic environment this product may cause radio interference in which case the user may be required to take adequate measures.

CONFIGURATION DIP-SWITCH

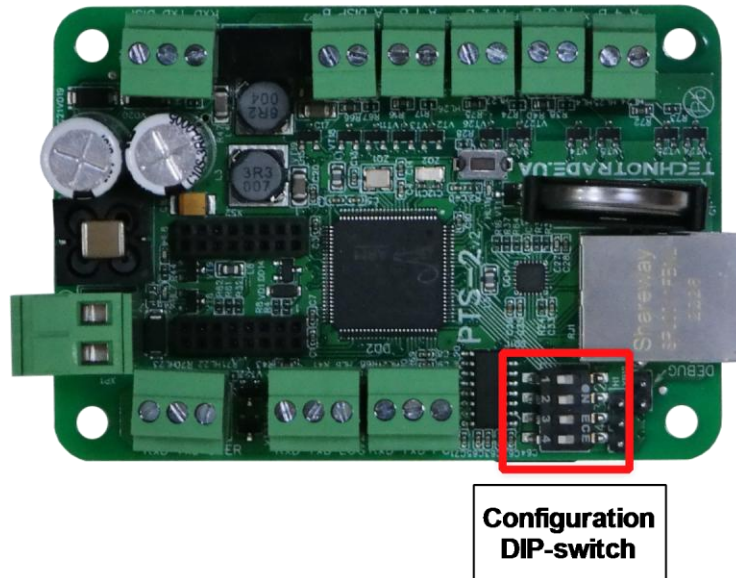

PTS-2 controller has a 4-position configuration DIP-switch, located on top of the PCB board. Appointment of the switches is the following:

1. **DIP-1 switch:**

- OFF position: communication through Ethernet using HTTPS protocol (by defaults port is 443)
- ON position: communication through Ethernet using HTTP protocol (by defaults port is 80)

2. **DIP-2 switch:**

- OFF position: digest authentication
- ON position: basic authentication

3. **DIP-3 switch:**

- OFF position: normal startup
- ON position: format of SD flash card on startup

4. **DIP-4 switch:**

- OFF position: normal startup
- ON position: reset of all configuration to default factory settings on startup

In case if both DIP-3 and DIP-4 switches are set to ON position same time – then on startup the PTS-2 controller does not format the SD-flash card, but resets all the configurations to default factory settings, after that the PTS-2 controller checks SD flash disk for a file *Config.js* containing backup of the configuration and if such file exists – then PTS-2 controller restores the configuration from it automatically. Thus, the configuration of the PTS-2 controller can be restored by placing the *Config.js* file to root of SD flash card and setting both DIP-3 and DIP-4 switches to ON position on startup.

NOTE! Configuration set on the DIP-switch is applied on startup. So, in case if the DIP-switch configuration is changed during the PTS-2 controller operation – it does not lead to any effect until the PTS-2 controller is restarted.

SD FLASH CARD

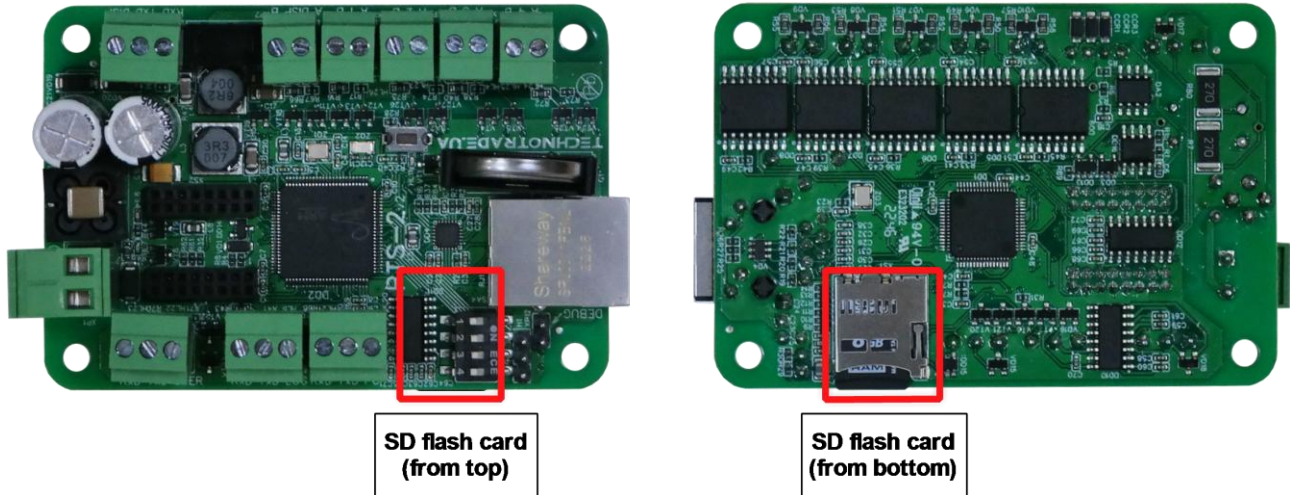

PTS-2 controller supports operation with SD flash card for leading the FAT32 file system.

SD flash disk is used for storing database files with pumps sales, tanks measurements, in-tank deliveries, alert records, GPS records, tank calibration charts, tags list, system log, configuration, settings, others. List of files and their structure are described in section [Files stored on SD flash disk](#).

NOTE! Operation status LED on PTS-2 controller board shows error, blinking fast and toggling its state each 100 ms in case if:

- SD flash disk is inserted incorrectly
- SD flash disk is not formatted to FAT32 file system or its file system is damaged

In this case it is necessary to recheck that the SD flash disk is inserted correctly and has a valid FAT32 file system. Also, it is possible to format the SD flash disk using DIP-3 switch of the configuration DIP-switch (see section [Configuration DIP-switch](#)).

NOTE! PTS-2 controller can operate without the SD card inserted. In this case PTS-2 controller ignores any operations with the SD card if any are configured to be used in it.

DEBUG PORT



Sometimes when it is difficult to find a reason of the problem, we might need to see debugging messages sent by the PTS-2 controller. For this it is possible to connect to a DEBUG port using some COM-port terminal. Communication settings are 115200 baud rate, 8 data bits, 1 stop bit, none parity.

CONNECTION TO CONTROL SYSTEMS USING ETHERNET INTERFACE

Connection to the control systems can be done through Ethernet port.

Scheme of connections:

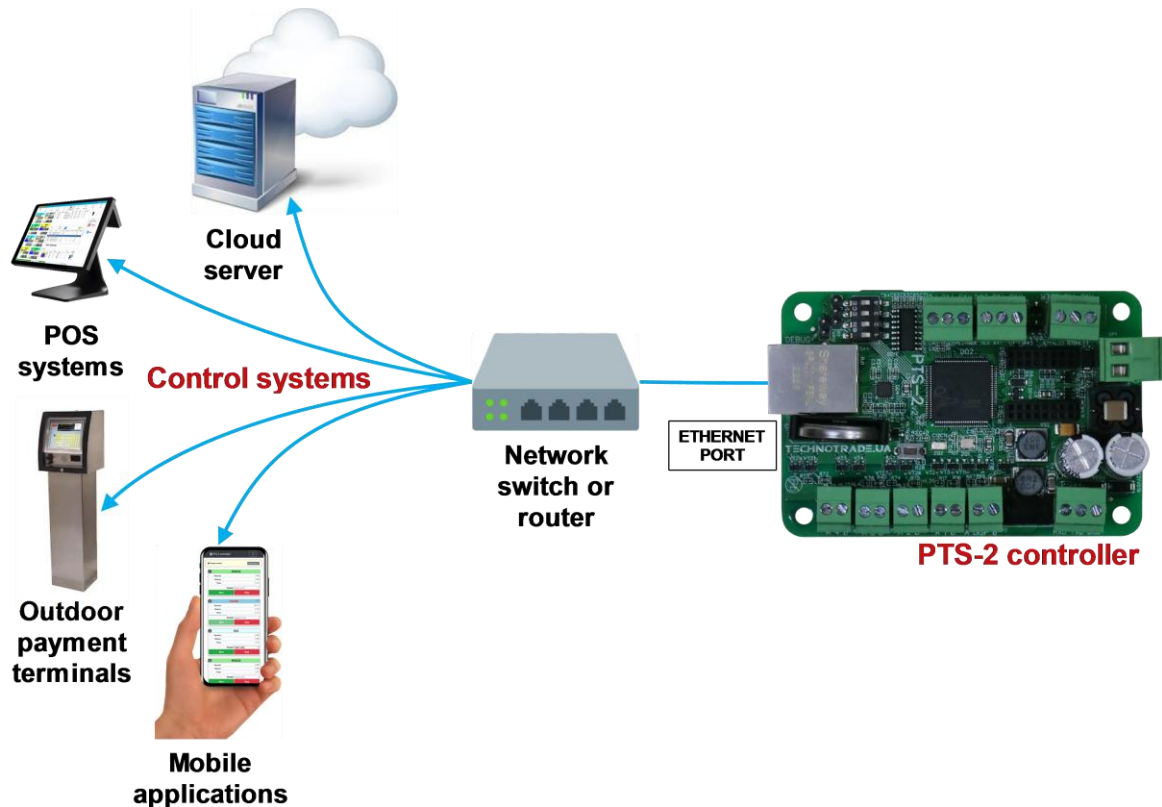

Communication with the PTS-2 controller is made using commands and responses described in jsonPTS communication protocol (own proprietary protocol of Technotrade LLC) – see document “*jsonPTS communication protocol specification for PTS-2 controller*” for more information.

CONNECTION TO CONTROL SYSTEMS USING RS-232 INTERFACE

Connection to the control system (POS system, cash register, OPT terminal, etc) can be also done through the PC port, which has the RS-232 interface (3 wires: TxD, RxD, Gnd).

Scheme of connections:

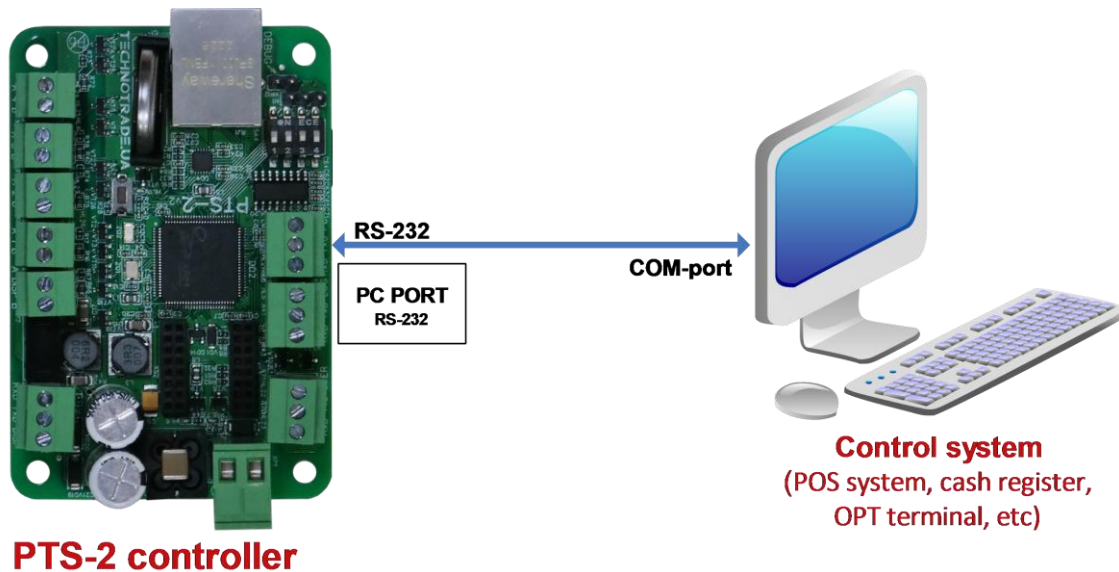

Pinout of cable used for connection RS-232 ports of PTS-2 controller to computer:

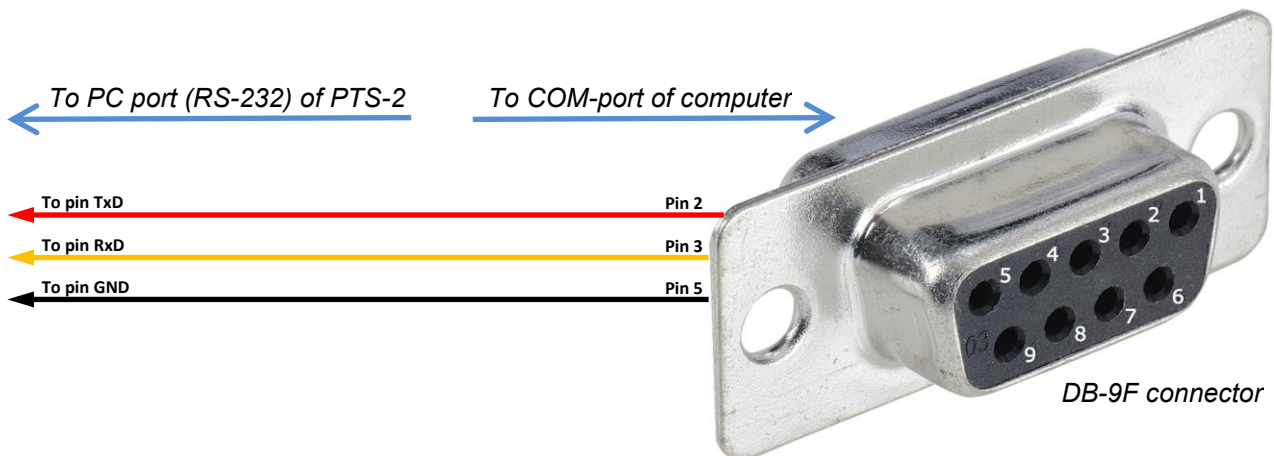

In case if the control system does not have a COM-port – it is possible to use any type of converter to COM-port (like USB-to-COM, Ethernet-to-COM, Bluetooth-to-COM, other converters).

Communication with the PTS-2 controller is made using commands and responses described in UniPump communication protocol (own proprietary protocol of Technotrade LLC) – see document “*UniPump communication protocol specification for PTS-2 controller over fuel dispensers and ATG systems*” for more information. Thus, PTS-2 controller provides conversion of the common communication protocol UniPump into various proprietary communication protocols of fuel dispensers and ATG systems.

Control over PTS-2 controller in this case is done same way as with PTS-1 controller (<http://www.technotrade.ua/fuel-pump-controller.html>). This mode is left intentionally for backward compatibility. The only difference in this mode is that PTS-2 controller supports control over up to 120 dispensers and up to 20 probes using the same UniPump protocol unlike PTS-1 controller, which is limited to 16 pumps and 16 probes maximum.

WEB-SERVER

General information

PTS-2 controller comes with a built-in web-server, which allows following possibilities:

- check of firmware information: firmware version and communication protocols included, system state, battery state, SD flash card state, unique identification number, GPS data, others
- configuration of pumps and ATG probes ports, price boards and readers, fuel grades, tanks and calibration charts, linking of pumps' nozzles to fuel grades and tanks, wireless receivers, users, parameters, others
- monitoring and control over dispensers and
- monitoring over tanks
- generation of reports on pumps sales, tanks measurements, in-tank deliveries, tanks reconciliation and GPS records and alerts
- logging of PTS-2 controller communication exchange with connected equipment
- self-diagnostics of the PTS-2 controller board and its peripheral units
- update of firmware

Web-server has adoptive user interface and was developed to suit to various types of mobile devices: computers, laptops, tablets, smartphones.

The screenshot displays the web interface for the PTS-2 controller. The header shows 'PTS-2 controller ver. 2023.04.12 13:24:54' and a user 'admin' with a 'Logout' link. The main content is organized into several sections:

- Device information:** A green header bar.
- FIRMWARE RELEASE:** Shows 'Release date/time: 2023.04.12 13:24:54'.
- DEVICE IDENTIFIER:** Shows 'ID: 003F003E3034511631323737'.
- PUMP PROTOCOLS:** A table with 10 entries:

Index	Communication protocol
1	Adast Easycall
2	UniPump
3	DART Complex
4	MM Petro ZAP RS-485
5	Gilbarco Two-Wire
6	Tokheim UDC
7	Tatsuno Benc PDE
8	Develco
9	Graf PMII
10	PumpControl

 Showing 1 to 10 of 66 entries.
- PROBE PROTOCOLS:** A table with 10 entries:

Index	Communication protocol
1	Gilbarco Veeder Root
2	Start Italiana SMT-XMT
3	Petrovend4
4	Struna Kedr spec. 1.4
5	Fafnir Visy-Quick
6	Assytech
7	ATG Simulator
8	Hectronic HLS
9	UniProbe
10	Vega

 Showing 1 to 10 of 35 entries.
- PRICE BOARD PROTOCOLS:** A section header at the bottom left.
- READER PROTOCOLS:** A section header at the bottom right.

Built-in web-server uses requests and responses described in *jsonPTS communication protocol* (own proprietary protocol of Technotrade LLC).

Communication to web-server is done using HTTP or HTTPS protocols depending on the position of switch 1 of configuration DIP-switch on the PTS-2 controller board (please check section [Configuration DIP-switch](#) for more information).

Connection to web-server

Default factory communication settings for PTS-2 controller:

- **IP-address:** 192.168.1.117
- **Network mask:** 255.255.255.0
- **Gateway:** 192.168.1.13
- **HTTP port:** 80
- **HTTPS port:** 443

Communication settings can be modified on [Configuration page](#) > [Settings](#) tab of web-server. Also, you can anytime reset the parameters to default using DIP-4 switch of configuration DIP-switch on the PTS-2 controller board (please check section [Configuration DIP-switch](#) for more information).

In order to initially connect to PTS-2 controller web-server for the first time from your computer we recommend to directly connect it to the PTS-2 controller using Ethernet interface and in network settings of the computer to set in configuration same network parameters as the PTS-2 controller has by defaults (just use a different IP-address), for example:

- **IP-address:** 192.168.1.10
- **Network mask:** 255.255.255.0
- **Gateway:** 192.168.1.13

After opening a web-browser in order to get to the web-server of the PTS-2 controller type in the address line one of the following addresses depending on the position of the DIP-1 switch defining usage of HTTP or HTTPS (please check section [Configuration DIP-switch](#) for more information):

- <http://192.168.1.117> (if DIP-1 is set to ON position)
- <https://192.168.1.117> (if DIP-1 is set to OFF position)

NOTE! PTS-2 controller is using a self-signed certificate, so at connection in web-browser using HTTPS protocol it may ask whether you trust the web-site or not.

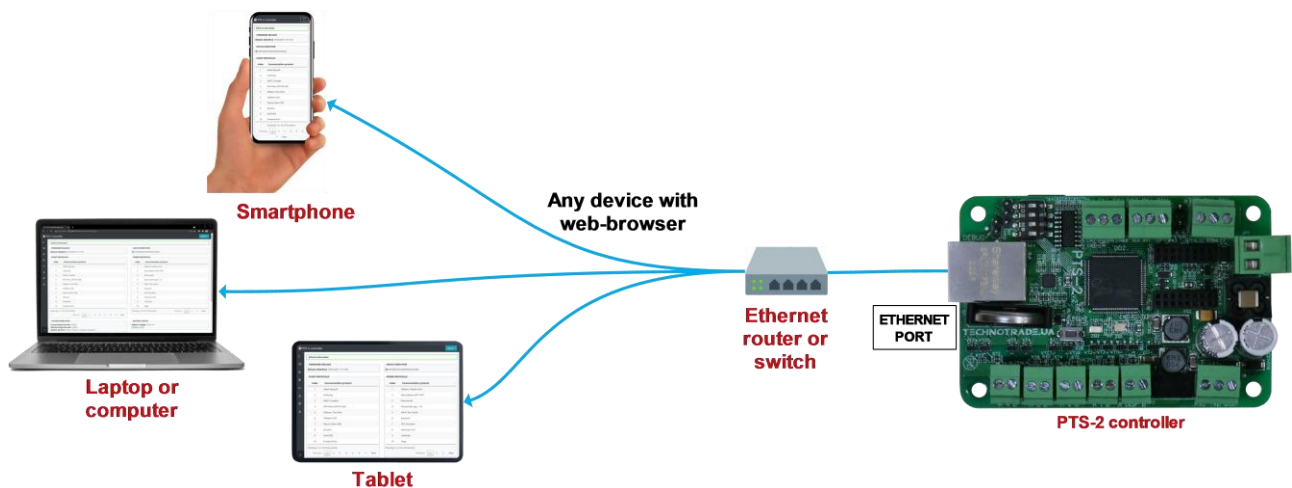

PTS-2 controller leads users and their permissions. For login into the web-server you should know the user credentials.

Default credentials for access to web-server are:

- **login:** *admin*
- **password:** *admin*

Sign in

http://192.168.1.117

Your connection to this site is not private

Username

Password

Device information page

Device information page serves for showing general information about PTS-2 controller firmware and hardware. You can check version of firmware and list of communication protocols included in it and also check state of battery, board unique identification number (used at upload of data to remote server) and SD flash disk memory state and files on it, at this any file can be downloaded from SD flash disk, GPS receiver status.

PTS-2 controller

ver. 2023.04.12 13:24:54

admin

[Logout](#)

i

i Device information

FIRMWARE RELEASE

Release date/time: 2023.04.12 13:24:54

DEVICE IDENTIFIER

ID: 003F003E3034511631323737

PUMP PROTOCOLS

Index	Communication protocol
1	Adast Easycall
2	UniPump
3	DART Complex
4	MM Petro ZAP RS-485
5	Gilbarco Two-Wire
6	Tokheim UDC
7	Tatsuno Benc PDE
8	Develco
9	Graf PMII
10	PumpControl

Showing 1 to 10 of 66 entries

Previous 1 2 3 4 5 6 7 Next

PROBE PROTOCOLS

Index	Communication protocol
1	Gilbarco Veeder Root
2	Start Italiana SMT-XMT
3	Petrovend4
4	Struna Kedr spec. 1.4
5	Fafnir Visy-Quick
6	Assytech
7	ATG Simulator
8	Hectronic HLS
9	UniProbe
10	Vega

Showing 1 to 10 of 35 entries

Previous 1 2 3 4 Next

PRICE BOARD PROTOCOLS

READER PROTOCOLS

PTS-2 controller
ver. 2023.04.12 13:24:54 admin
Logout

Showing 1 to 2 of 2 entries

3	Top Screens
4	Gilbarco Remote Price Sign
5	Novyc RS-232 protocol

Showing 1 to 5 of 5 entries

BATTERY STATE
Battery voltage: 3.055 mV
Battery is OK.

CPU TEMPERATURE
CPU temperature: 41 °C

SD FLASH DISK
Used memory: 1632 KB
Total memory: 8 GB

Files:

- 01CALIB.CSV: 2814 B ([download](#), [delete](#))
- ALERTS.CSV: 166241 B ([download](#), [delete](#))
- CONFIG.JS: 52098 B ([download](#), [delete](#))
- PORTLOG.BIN: 24865 B ([download](#), [delete](#))
- PTSLOG.TXT: 796401 B ([download](#), [delete](#))
- PUMPTRN.CSV: 1812 B ([download](#), [delete](#))
- SD_TEST.TXT: 19 B ([download](#), [delete](#))
- SETTINGS.INI: 675 B ([download](#), [delete](#))
- TAGS.CSV: 197 B ([download](#), [delete](#))
- TANKDLV.CSV: 7069 B ([download](#), [delete](#))
- TANKMSR.CSV: 10212 B ([download](#), [delete](#))
- _PORTLOG.BIN: 166755 B ([download](#), [delete](#))

GPS RECEIVER DATA

Date/time: 12.04.2023 12:54:34
Latitude: 5029.8919 DD°MM.mmmm' North
Longitude: 03029.9247 DDD°MM.mmmm' East
Speed over ground: 0.9 km/h
Course over ground: 174.18°
Mode: Autonomous

SYSTEM OPERATION

Current heap free size: 13136 B
Minimal heap free size: 13048 B
System up time: 0 days, 0 hours, 0 minutes, 19 seconds

PTS-2 controller developed by Technotrade LLC

NOTE! Pay attention that the PTS-2 controller is using latest version of the firmware. Latest version of firmware can be received upon request from Technotrade LLC company or downloaded from Technotrade LLC company website.

NOTE! In case if battery voltage is lower than required (lower than 3 V DC) – then it is strictly required to replace the battery with a new one, otherwise the PTS-2 controller may not keep the system date and time correctly, which will lead to problems with saving of records to database, automatic detection of in-tank deliveries and other operations requiring to know present time.

NOTE! PTS-2 controller may work without SD flash disk inserted, but at this all operations concerning saving of data to SD flash disk will not be performed by PTS-2 controller. It is recommended to always use the SD flash disk.

Configuration page

Configuration page contains all the settings of PTS-2 controller, which are divided in tabs.

Settings tab

On Settings tab you can configure following settings:

- system date and time for PTS-2 controller with a possibility to automatically synchronize with a time server and settings the UTC offset: time is used in many operations in PTS-2 controller including saving of records to database, calculation of in-tank deliveries, internal operations. For PTS-2 controller to lead time correctly there should be a battery inserted in the board.
- network settings of PTS-2 controller (IP-address, network mask, gateway, ports for HTTP and HTTPS, DNS servers)
- remote server configuration, to where the PTS-2 controller can upload data or establish WebSocket communication (IP-address, domain name, URI, user credentials, port, selection of data for upload, WebSocket communication)
- backup and restore configuration
- daily files processing time
- restart button for instant PTS-2 controller restart

NOTE! As default port for HTTP is 80 and default port for HTTPS is 443, it allows not to enter any port in web-browser address line at addressing to PTS-2 controller when these ports are configured, for example address <http://192.168.1.117> automatically equals <http://192.168.1.117:80> and <https://192.168.1.117> automatically equals <https://192.168.1.117:443>.

NOTE! In order for automatic time synchronization to work and also upload of data to remote server to work the gateway value should be configured in accordance to the network, to which PTS-2 controller is connected.

The screenshot displays the web interface of the PTS-2 controller. At the top, the header shows 'PTS-2 controller ver. 2023.04.12 13:24:54' and a user profile 'admin Logout'. The main navigation bar includes tabs for 'Configuration', 'Pumps', 'Probes', 'Parameters', 'Grades', 'Tanks', 'Nozzles', 'Boards', 'Readers', 'Wireless', and 'Users'. The 'Settings' tab is selected, showing the following configuration options:

- DATE/TIME**
 - System date/time:** 12.04.23 17:24:07. Description: Sets system date/time in format dd.MM.yy hh:mm:ss.
 - Auto sync:** A toggle switch is currently turned on. Description: Automatic synchronization with time server.
 - UTC offset:** A dropdown menu is set to '+', with sub-selects for '3 h' and '0 min'. Below are 'Get' and 'Set' buttons.
- NETWORK SETTINGS**
 - IP-address:** 192.168.1.117. Description: Sets IP-address in IPv4 in format xxx.xxx.xxx.xxx.
 - Network mask:** 255.255.255.0. Description: Sets network mask in format xxx.xxx.xxx.xxx.
 - Gateway:** 192.168.1.13. Description: Sets gateway in format xxx.xxx.xxx.xxx.

PTS-2 controller
ver. 2023.04.26 17:32:15
admin
Logout

REMOTE SERVER SETTINGS

Server IPv4 address

Sets IP-address in IPv4 in format xxx.xxx.xxx.xxx. If there is no static IP-address available - then set here value 0.0.0.0 and below set the server domain name.

Domain name

Domain name (if exists)

Server user

Credentials for remote server access are taken from user configuration

Use device identifier as login

Timeout of server response

Sets the maximum period in seconds to wait for a message from the server (response in case of data upload data or a new request in case of WebSocket communication)

Data upload

Upload pump transactions

Sets polling by the controller to remote server for upload of performed pump transactions

Server request URI

Server request URI without starting slash

Uploaded records number: 5 [Reset](#)

Total records number: 5

Websocket communication

Use Websocket communication

Sets to use communication between the controlles and a remote server using Websocket protocol

Server request URI

Server request URI without starting slash

PTS-2 controller
ver. 2023.04.12 13:24:54
admin
Logout

Upload status

Sets periodic polling by the controller to remote server for informing about state and check of communication

Server request URI

Server request URI without starting slash

Period between uploading status requests

in seconds

Server port

Secret key

Secret key used for messages signature. Usage of digital signature ensures messages' authentication and integrity. Parameter is optional. Set the flag if necessary to update the value, if the flag is not set - then a previously entered value is to be used.

Update previously entered value

Server communication status ✔

Get

Set

NOTE! Read more about communication to a remote server in section [Communication to remote server](#).

The screenshot displays the web interface for the PTS-2 controller. At the top, it shows 'PTS-2 controller ver. 2023.04.12 13:24:54' and 'admin Logout'. The interface is divided into several sections:

- Get/Set:** Two buttons at the top for retrieving or setting configuration.
- BACKUP/RESTORE CONFIGURATION:** A section showing 'CONFIG.JS: 52098 B (download)'. It includes a 'Select file' input with a 'Browse' button and a success message: 'Configuration file uploaded successfully!' with a '100%' progress bar. Below this are 'Backup' and 'Restore' buttons.
- DAILY FILES PROCESSING TIME:** A section with a 'Daily files processing time' input field set to '03:00'. A description states: 'Sets time for files processing stored on SD flash disk of the controller. Files are processed once a day at the specified time, the process may take several minutes.' Below this is a toggle for 'Make automatic backup of controller configuration' which is currently turned on. A description for the toggle says: 'Sets automatic daily backup of controller configuration.' At the bottom of this section are 'Get' and 'Set' buttons.
- RESTART:** A section with a 'Restart controller' button.

At the bottom left, it says '>> PTS-2 controller developed by Technotrade LLC' and at the bottom right, there is an upward arrow icon.

BACKUP/RESTORE CONFIGURATION field allows to save all the PTS-2 configuration to a file named *Config.js* and download it to save. Also, any time it is possible to upload the configuration file *Config.js* and restore configuration from it to the controller.

NOTE! During firmware update backup of configuration is made automatically in order to restore it correctly after the firmware is updated.

DAILY FILES PROCESSING TIME field is used to set the time when the controller is able to process the files stored on SD flash disk in order to optimize them, normally this procedure takes up to a minute and is done only sometimes when any problems with the files is found.

Pumps tab

This tab allows to configure each pump port (4 pump ports totally) to separate communication protocol and baud rate. Also, you can configure each of the pumps (up to 120) to its own pump port and assign it a physical address (communication address configured inside the dispenser). You can configure many dispensers to the same port.

PTS-2 controller
ver. 2023.04.12 13:24:54

admin
Logout

Configuration

Settings Pumps Probes Parameters Grades Tanks Nozzles Boards Readers Wireless Users

Get

PUMP PORTS CONFIGURATION

Edit	Port	Protocol	Baud rate
	1	33. DART Simplex	4. 9600
	2	5. Gilbarco Two-Wire	3. 5787
	3	0. -----	0. -----
	4	15. Tatsuno SS-LAN	5. 19200

Set

PUMPS CONFIGURATION

Edit	Pump	Pump port	Physical address
	1	1 port	2 address
	2	1 port	3 address
	3	2 port	7 address
	4	2 port	11 address
	5	4 port	1 address
	6	4 port	2 address
	7	4 port	3 address
	8	0 -----	0 -----
	9	0 -----	0 -----
	10	0 -----	0 -----

Showing 1 to 10 of 50 entries

Previous 1 2 3 4 5 Next

Configuration of pump ports includes setting of communication protocol and baud rate for each of the pump ports and also assigning of pumps to each of the pump ports. Each of the pumps can be assigned to any of the pump ports and requires specification of the pump physical address.

Physical address of the pump means communication address (also named as ID or pump number) of the real fueling place, which is programmed or set in configuration of the fuel dispenser fueling place.

Edit record

Protocol: 15. Tatsuno SS-LAN

Baud rate: 5. 19200

Update

Probes tab

This tab allows to configure each probe port (up to 3 probe ports) to separate communication protocol and baud rate. Also, you can configure each of the probes (up to 20) to its own probe port and assign it a physical address (communication address set in probe or in ATG console). You can configure many probes to the same port.

The screenshot shows the 'Probes' configuration tab in the PTS-2 controller interface. It is divided into two main sections: 'Get' and 'Set'.

PROBE PORTS CONFIGURATION (Get):

Edit	Port	Protocol	Baud rate
	DISP	24. Fafnir Torrix RS-485	4. 9600
	LOG	0. -----	0. -----
	USER	1. Gilbarco Veeder Root	4. 9600

PROBES CONFIGURATION (Set):

Edit	Probe	Probe port	Physical address
	1	USER	1
	2	USER	2
	3	DISP	1
	4	DISP	2
	5	DISP	3
	6	0 -----	0
	7	0 -----	0
	8	0 -----	0
	9	0 -----	0
	10	0 -----	0

Showing 1 to 10 of 50 entries
 Previous 1 2 3 4 5 Next

Configuration of probe ports includes setting of communication protocol and baud rate for each of the probe ports and also assigning of probes to each of the probe ports. Each of the probes can be assigned to any of the probe ports and requires specification of the probe physical address.

Physical address of the probe means address of the ATG system probe, which is programmed or set in configuration of the ATG system console or in probe (in some models of probes address mean serial number stated on the probe label).

✕

Edit record

Protocol: 1. Gilbarco Veeder Root

Baud rate: 4. 9600

Update

Parameters tab

On this tab you can configure parameters for

- PTS-2 controller
- pumps
- probes
- price-boards
- readers

All parameters are listed in a table with detailed description. Default parameters values are specified in a separate column. If you press a button *Set default* – then default values for all parameters will be applied.

Parameters are specific settings used in PTS-2 controller. List of parameters depends on firmware version of PTS-2 controller. The whole list of parameters is stored in separate files *Pts_config_xx.js* (xx – name of used language), please see section [Configuration files Pts_config_xx.js](#) in this document for more details.

PTS-2 controller parameters

PTS-2 controller parameters define specific system settings for operation of the PTS-2 controller in general.

The screenshot shows the 'Parameters' configuration page for the PTS-2 controller. The page has a dark sidebar on the left with navigation icons. The top bar displays 'PTS-2 controller ver. 2023.04.12 19:28:39' and 'admin Logout'. Below the top bar is a 'Configuration' header with a gear icon. A horizontal menu contains tabs for 'Settings', 'Pumps', 'Probes', 'Parameters' (active), 'Grades', 'Tanks', 'Nozzles', 'Boards', 'Readers', 'Wireless', and 'Users'. Below the menu are three buttons: 'Get', 'Set', and 'Set default'. A 'Device' dropdown menu is set to 'Controller'. The main content area features a table with columns 'Description', 'Default', and 'Value'. The table is divided into sections, with the first section being '1. GENERAL SETTINGS'. The parameters listed are:

Description	Default	Value
1. GENERAL SETTINGS		
1.1. GUI language Sets languages used for graphical user interface of web-server.	English	English
1.2. Volume measurement units Sets measurement units used in system for volume.	Liters	Liters
1.3. Temperature measurement units Sets measurement units used in system for temperature.	Degrees Celcius	Degrees Celcius
1.4. Base temperature for product temperature-compensated volume Sets the base temperature for calculation of temperature-compensated volume of product in tank based on present volume, temperature and fuel grade temperature expansion coefficient.	15 degrees Celcius	15 degrees Celcius
1.5. Stop pumps on power failure Sets whether stop command should be automatically sent to pumps in case of controller power failure detection.	0	<input type="checkbox"/>
1.6. In the end of filling price on pump should be displayed equal to price of the used fuel grade Sets whether the price on the pump in the end of filling should be set to default price configured for used		

Parameters are grouped into the following sections:

- *GENERAL SETTINGS* describe general things like used language, units of measurements, etc.
- *SD FLASH DISK SETTINGS* describe parameters related to SD flash disk like saving to database
- *PORT FLEXIBLE COMMUNICATION SETTINGS* provide setting of communication parameters for ports
- *DECIMAL DIGITS SYSTEM SETTINGS* set the number of decimal digits in volume, amount and price
- *GPS SETTINGS* allow to configure parameters for the GPS module
- *LOGGING SETTINGS* are used for managing the logs, which is useful in problematic situations.
- *READER SETTINGS* allow to set how long the tag identifier should be stored after successful reading.
- *NON-ADDRESSABLE INTERFACE CONVERTERS OPERATION SETTINGS* are used for operation with NA interface converters (<https://www.technotrade.ua/non-addressable-interface-converter.html>).

Pump parameters

PTS-2 controller foresees specific configuration parameters for each of the pumps. Pump parameters are divided into:

- specific parameters for used pump protocol – such parameters depend on the used communication protocol and are different for different communication protocols
- common parameters, which are same for all pumps regardless of the used communication protocol

The screenshot shows the 'Parameters' configuration page in the PTS-2 controller web interface. The page title is 'PTS-2 controller' with version '2023.04.12' and time '19:28:39'. The user is logged in as 'admin'. The navigation menu includes 'Settings', 'Pumps', 'Probes', 'Parameters', 'Grades', 'Tanks', 'Nozzles', 'Boards', 'Readers', 'Wireless', and 'Users'. The 'Parameters' section has three buttons: 'Get', 'Set', and 'Set default'. Below these buttons, there are three dropdown menus: 'Device' (set to 'Pump'), 'Number' (set to '1'), and 'Protocol' (set to '33. DART Simplex'). There is a toggle switch for 'Get parameters values automatically' which is currently turned on. The main content area is a table with columns 'Description', 'Default', and 'Value'. The table is divided into sections: '1. PUMP PROTOCOL SPECIFIC PARAMETERS', '1.1. Nozzles quantity on pump side', '1.2. Use money total counters', '1.3. No FILLING state during dispensing', '1.4. S4 computer is used', '1.5. Enable fast communication', and '1.6. Unite commands at authorization'.

Description	Default	Value
1. PUMP PROTOCOL SPECIFIC PARAMETERS		
1.1. Nozzles quantity on pump side Sets quantity of nozzles used on pump side.	6	3
1.2. Use money total counters Sets whether the money amount total counters should be requested from the dispenser (set in case if they are supported by the dispenser).	No	Using command code 0x65 (bit ▾)
1.3. No FILLING state during dispensing Sets whether a pump does not return FILLING state during dispensing.	0	<input type="checkbox"/>
1.4. S4 computer is used Sets whether a pumphead is using S4 computer.	0	<input type="checkbox"/>
1.5. Enable fast communication Sets whether fast communication with pump should be used. May be not supported by some pumps!	0	<input checked="" type="checkbox"/>
1.6. Unite commands at authorization		

Common parameters divide into following sections:

- *PUMP AUTHORIZATION SETTINGS* – contains various configurations for authorization (for example, to authorize the pump only after nozzle up, automatic authorization and other)
- *TAG VERIFICATION SETTINGS* – contains parameters for operation with tags on the pumps (for example to always verify a tag before sending authorization to the pump)
- *TIMER SETTINGS* – contains timing configurations of the pumps (for example how long to keep the pump authorized without any activity on it)
- *PUMP MULTIPLIERS* – contains settings for adjusting the values of volume, price and amount in case of specific pump display configurations
- *PUMP NOZZLE READERS SETTINGS FOR AUTOMATIC VEHICLES IDENTIFICATION SYSTEM* – contains settings for the AVI system readers installed on the pump nozzles

Probe parameters

PTS-2 controller foresees specific configuration parameters for each of the probes. Probe parameters are divided into:

- specific parameters for used probe protocol – such parameters depend on the used communication protocol and are different for different communication protocols
- common parameters, which are same for all probes regardless of the used communication protocol

The screenshot shows the 'Parameters' configuration page in the PTS-2 controller interface. The page is titled 'Configuration' and has a navigation menu with options like Settings, Pumps, Probes, Parameters, Grades, Tanks, Nozzles, Boards, Readers, Wireless, and Users. The 'Parameters' tab is active, and the 'Get' button is highlighted. Below the navigation, there are fields for 'Device' (Probe), 'Number' (1), and 'Protocol' (1. Gilbarco Veeder Root). A toggle switch for 'Get parameters values automatically' is turned on. The main content area is a table with columns 'Description', 'Default', and 'Value'.

Description	Default	Value
1. PROBE GENERAL SETTINGS		
1.1. Probe offset from tank bottom, mm Sets offset between probe bottom edge and tank's bottom in millimeters, this setting is used for automatic calculation of product and water volume based on tanks' calibration charts.	0	5
1.2. Negative probe offset from tank bottom, mm Sets negative value for offset between probe bottom edge and tank's bottom.	0	<input type="checkbox"/>
1.3. Probe water float minimal level, mm Sets minimal water level, which can be detected by the probe in millimeters. For lesser water level the controller will provide 0 for water level. This parameter is needed for some magnetostrictive probes, in which due to the construction of the water float in the bottom of the probe informs some water level value even if there is no water present.	0	5
1.4. Automatic calculation of product volume Sets to enable automatic calculation of product volume in tanks based on tanks' calibration charts. This option needs tanks to have calibration charts configured in controller.	0	<input checked="" type="checkbox"/>

In common parameters it is possible to configure different settings, for example:

- probe offset from a tank's bottom
- automatic calculation of product volume based on tank's calibration chart
- automatic calculation of product temperature compensated volume
- automatic registration of in-tank deliveries
- automatic calculation of product mass
- automatic check of alarms
- automatic tank leakage detection
- others

Price board parameters

PTS-2 controller foresees specific configuration parameters for each of the price boards. Price board parameters are divided into:

- specific parameters for used price board protocol – such parameters depend on the used communication protocol and are different for different communication protocols
- common parameters, which are same for all price boards regardless of the used communication protocol

The screenshot displays the 'Parameters' configuration page in the PTS-2 controller interface. The page is titled 'Configuration' and includes a sidebar with various system components. The 'Parameters' section is highlighted, and the 'Get' button is active. The 'Device' is set to 'Price board', 'Number' is '1', and 'Protocol' is '1. PWM In-House'. A toggle for 'Get parameters values automatically' is enabled. The main content area shows a table of parameters for price board general settings.

Description	Default	Value
1. PRICE BOARD GENERAL SETTINGS		
1.1. Price multiplier for display 1 Sets multiplier for price value for display 1.	x1	x1
1.2. Price multiplier for display 2 Sets multiplier for price value for display 2.	x1	x1
1.3. Price multiplier for display 3 Sets multiplier for price value for display 3.	x1	x1
1.4. Price multiplier for display 4 Sets multiplier for price value for display 4.	x1	x1
1.5. Price multiplier for display 5 Sets multiplier for price value for display 5.	x1	x1
1.6. Price multiplier for display 6 Sets multiplier for price value for display 6.	x1	x1

In common parameters it is possible to configure multipliers for the price displays, which allow to move the displayed price value on price display to left or right direction.

Reader parameters

PTS-2 controller foresees specific configuration parameters for each of the readers. Reader parameters are divided into:

- specific parameters for used reader protocol – such parameters depend on the used communication protocol and are different for different communication protocols
- common parameters, which are same for all readers regardless of the used communication protocol

The screenshot displays the 'Parameters' configuration page for a reader in the PTS-2 controller web interface. The interface includes a top navigation bar with 'admin' and 'Logout' links, and a sidebar with various configuration options. The main content area is titled 'Configuration' and contains several tabs: Settings, Pumps, Probes, Parameters (selected), Grades, Tanks, Nozzles, Boards, Readers, Wireless, and Users. Below the tabs are three buttons: 'Get', 'Set', and 'Set default'. The 'Set' button is active, and the configuration fields are populated with 'Device: Reader', 'Number: 1', and 'Protocol: 1. VRD-485'. A toggle switch for 'Get parameters values automatically' is turned on. The main configuration area is a table with columns for 'Description', 'Default', and 'Value'.

Description	Default	Value
1. READER PROTOCOL SPECIFIC PARAMETERS		
1.1. Reader type Sets type of reader used.	VRD-485 (EM-marine)	VRD-485M (EM-marine + Mifare)
1.2. Include EM-marine chip manufacture ID to tag Sets to include the Em-marine chip manufacturer ID to the first byte of read tag.	0	<input checked="" type="checkbox"/>
1.3. Include Mifare chip type to tag Sets to include the Mifare chip type to the first two bytes of read tag.	0	<input checked="" type="checkbox"/>

PTS-2 controller developed by Technotrade LLC

Grades tab

This tab allows to configure fuel grades used in the PTS-2 controller. This includes settings of fuel grade name, price per liter/gallon and setting of temperature-expansion coefficient. Also, if there are blended fuel grades – then it is possible to set here the tanks, from which it is mixed (prior to this it is needed to configure tanks on [Tanks](#) tab).

Edit	No.	Name	Price	Temperature expansion coefficient	Blended tank 1	Blend percentage	Blended tank 2
	1	Petrol	1.11	0.0011	0	0	0
	2	Diesel	1.05	0.00082	0	0	0
	3	LPG	0.87	0.00245	0	0	0
	4	Kerosene	1.01	0.00087	0	0	0
	5		0	0.00000	0	0	0
	6		0	0.00000	0	0	0
	7		0	0.00000	0	0	0
	8		0	0.00000	0	0	0
	9		0	0.00000	0	0	0
	10		0	0.00000	0	0	0

NOTE! Number of decimal digits in price is configured in parameters of PTS-2 controller on tab [Parameters](#).

NOTE! Temperature-expansion coefficient is needed for automatic calculation of temperature-compensated volume in tanks and also dispensed by pumps.

For general liquids a linear correction factor can be applied to give volumetric flow at base condition. The thermal expansion coefficient for liquids is determined empirically and can be found in chemical engineering texts. Thermal coefficients of expansion at 15 °C for various liquids:

PRODUCT	COEFFICIENT OF EXPANSION / °C	PRODUCT	COEFFICIENT OF EXPANSION / °C
<i>LPG propane</i>	0.00290	<i>Crude oil (bass strait)</i>	0.00087
<i>LPG butane</i>	0.00200	<i>Benzene</i>	0.00120
<i>Aviation gasoline</i>	0.00120	<i>Toluene</i>	0.00110
<i>Petrol</i>	0.00110	<i>Xylene</i>	0.00100
<i>Aviation jet a-1</i>	0.00094	<i>White spirit</i>	0.00095
<i>Lightning kerosene</i>	0.00094	<i>Mineral turpentine</i>	0.00087
<i>Power kerosene</i>	0.00087	<i>Lube oils:</i>	
<i>Heating oil</i>	0.00087	<i>SAE10</i>	0.00077
<i>Automotive distillate</i>	0.00084	<i>SAE20</i>	0.00076
<i>Industrial diesel fuel</i>	0.00082	<i>SAE30</i>	0.00076
<i>Fuel oil high sulphur</i>	0.00070	<i>SAE40</i>	0.00074
<i>Fuel oil low sulphur</i>	0.00075	<i>SAE50</i>	0.00074
<i>Bitumen</i>	0.00063	<i>Water</i>	0.00031

Tanks tab

This tab allows to configure tanks: to set tank's fuel grade, height, alarms. Also, you can assign a calibration chart for each of the tanks and check it.

Get					Set				
Edit	Tank	Fuel grade	Height, mm	Critical high product alarm, mm	High product alarm, mm	Low product alarm, mm	Critical low product alarm, mm	High water alarm, mm	Stop pumps at reaching the critical low product height
	1	Grade 1 (Petrol, price: 1.11)	3750	3700	3650	150	100	50	Yes
	2	Grade 2 (Diesel, price: 1.05)	3250	3200	3150	150	100	50	Yes
	3	Grade 3 (LPG, price: 0.87)	1750	1700	1650	100	50	0	No
	4	Grade 4 (Kerosene, price: 1.01)	2750	2700	2650	150	100	50	Yes
	5	0	0	0	0	0	0	0	No
	6	0	0	0	0	0	0	0	No
	7	0	0	0	0	0	0	0	No

Edit record

Fuel grade: Grade 1 (Petrol, price: 1.11) ▼

Height, mm:

Critical high product alarm, mm:

High product alarm, mm:

Low product alarm, mm:

Critical low product alarm, mm:

High water alarm, mm:

Stop pumps at reaching the critical low product height: Yes No

NOTE! It is assumed that tanks' IDs completely correspond to probes' IDs in meaning: tank 1 corresponds to probe 1, tank 2 – to probe 2, tank N – to probe N.

It is possible to apply alarms for high and low product and water levels and also to set to stop pumps automatically when the product level lowers below the critical low value.

For assigning a tank calibration chart it is necessary to select a row in a table for specific tank and in field under a tanks table to select a path to the tank calibration chart file.

The screenshot shows the PTS-2 controller web interface. At the top, it displays 'PTS-2 controller ver. 2021.12.13 10:38:43' and 'admin Logout'. Below this is a table with columns for tank ID, grade, price, and various numerical values. The table shows 10 rows, with the first row selected. Below the table, there is a pagination control showing 'Showing 1 to 10 of 50 entries 1 row selected' and 'Previous 1 2 3 4 5 Next'. A modal window titled 'TANK CALIBRATION CHART' is open, showing 'Tank number: 1' and 'Calibration chart file: 01CALIB.CSV: 5712 B (download)'. The modal has an 'Upload new file:' section with a 'Browse' button. Below that is a 'Check volume:' section with 'Input level in millimeters:' and a text input field containing '100'. A 'Calculate volume' button is present, and the result shows 'Calculated volume (liters, gallons, other): 441'.

Tank ID	Grade	Price
4	Grade 4 (LPG, price: 0.87)	1750	1700	1650	100	50	0	Yes	
5	0	0	0	0	0	0	0	No	
6	0	0	0	0	0	0	0	No	
7	0	0	0	0	0	0	0	No	
8	0	0	0	0	0	0	0	No	
9	0	0	0	0	0	0	0	No	
10	0	0	0	0	0	0	0	No	

Button *Calculate volume* allows to check tank's calibration chart by checking volume for any level entered.

The screenshot shows the 'TANK CALIBRATION CHART' modal after a file upload. It displays 'Tank number: 1' and 'Calibration chart file: 01CALIB.CSV: 5712 B (download)'. The 'Upload new file:' section shows a file named '01Calib.csv' uploaded successfully, with a progress bar at 100%. Below that is the 'Check volume:' section with 'Input level in millimeters:' and a text input field containing '131'. A 'Calculate volume' button is present, and the result shows 'Calculated volume (liters, gallons, other): 700'.

NOTE! It is possible to set a calibration chart for the tank after configuration of tanks is saved.

NOTE! Structure of tank calibration chart files is described in section [Files stored on SD flash disk.](#)

Nozzles tab

This tab allows to configure linkage of pump nozzles to fuel grades and to tanks (optional).

PTS-2 controller
ver. 2023.04.15 16:52:28 admin
Logout

Configuration

Settings Pumps Probes Parameters Grades Tanks **Nozzles** Boards Readers Wireless Users

Get				Set									
Edit	Pump	Grade noz. 1	Tank noz. 1	Grade noz. 2	Tank noz. 2	Grade noz. 3	Tank noz. 3	Grade noz. 4	Tank noz. 4	Grade noz. 5	Tank noz. 5	Grade noz. 6	Tank noz. 6
	1	Grade 1 (Petrol, price: 1.11)	Tank 1 (Petrol)	Grade 2 (Diesel, price: 1.05)	Tank 2 (Diesel)	0	0	0	0	0	0	0	0
	2	Grade 2 (Diesel, price: 1.05)	Tank 2 (Diesel)	Grade 1 (Petrol, price: 1.11)	Tank 1 (Petrol)	0	0	0	0	0	0	0	0
	3	Grade 1 (Petrol, price: 1.11)	Tank 1 (Petrol)	Grade 2 (Diesel, price: 1.05)	Tank 2 (Diesel)	Grade 4 (Kerosene, price: 1.01)	Tank 4 (Kerosene)	0	0	0	0	0	0
	4	Grade 4 (Kerosene, price: 1.01)	Tank 4 (Kerosene)	Grade 2 (Diesel, price: 1.05)	Tank 2 (Diesel)	Grade 1 (Petrol, price: 1.11)	Tank 1 (Petrol)	0	0	0	0	0	0
	5	Grade 3 (LPG,	Tank 3	0	0	0	0	0	0	0	0	0	0

Edit record

Fuel grade for nozzle 1:

Tank for nozzle 1 (optionally):

Fuel grade for nozzle 2:

Tank for nozzle 2 (optionally):

Fuel grade for nozzle 3:

Tank for nozzle 3 (optionally):

Fuel grade for nozzle 4:

Tank for nozzle 4 (optionally):

Fuel grade for nozzle 5:

Tank for nozzle 5 (optionally):

Fuel grade for nozzle 6:

Boards tab

This tab allows to configure ports for communication with price boards, you can configure each of the price boards (up to 5) to its own port and assign it a physical address (communication address configured inside the price board). You can configure many price boards to the same port.

The screenshot shows the 'Boards' configuration page in the PTS-2 controller interface. At the top, there's a navigation bar with options like Settings, Pumps, Probes, Parameters, Grades, Tanks, Nozzles, **Boards**, Readers, Wireless, and Users. Below this, there are 'Get' and 'Set' buttons. The main content area is divided into two sections:

PRICE BOARD PORTS CONFIGURATION

Edit	Port	Protocol	Baud rate
	DISP	1. PWM In-House	6. 1200
	LOG	0.	0.
	USER	0.	0.

PRICE BOARDS CONFIGURATION

Edit	Price board	Port	Physical address	Grade 1	Grade 2	Grade 3	Grade 4	Grade 5	Grade 6	Grade 7	Grade 8	Grade 9	Grade 10
	1	DISP	1 address	Grade 1 (Petrol, price: 1.11)	Grade 2 (Diesel, price: 1.05)	Grade 4 (Kerosene, price: 1.01)	Grade 3 (LPG, price: 0.87)	0	0	0	0	0	0
	2	0----	0-----	0	0	0	0	0	0	0	0	0	0
	3	0----	0-----	0	0	0	0	0	0	0	0	0	0

Configuration of ports includes setting of communication protocol and baud rate for each of the ports and also assigning the price boards to each of the ports. Each of the price boards should be also assigned grades, which prices it has to show on its displays (up to 10 prices per the price board). Price board configuration table also displays price boards' statuses (online state and errors present in communication using icons).

Edit record

Price board port:

Communication address:

Fuel grade 1:

Fuel grade 2:

Fuel grade 3:

Fuel grade 4:

Fuel grade 5:

Fuel grade 6:

Fuel grade 7:

Fuel grade 8:

Fuel grade 9:

Fuel grade 10:

Readers tab

This tab allows to configure ports for communication with readers, you can configure each of the readers (up to 120) to its own port and assign it a physical address (communication address configured inside the reader). You can configure many readers to the same port.

The screenshot displays the 'Readers' configuration page in the PTS-2 controller interface. The top navigation bar includes 'Settings', 'Pumps', 'Probes', 'Parameters', 'Grades', 'Tanks', 'Nozzles', 'Boards', 'Readers', 'Wireless', and 'Users'. The 'Readers' tab is active. Below the navigation, there are 'Get' and 'Set' buttons. The main content area is divided into two sections: 'READER PORTS CONFIGURATION' and 'READERS CONFIGURATION'.

READER PORTS CONFIGURATION

Edit	Port	Protocol	Baud rate
	DISP	1. VRD-485	4. 9600
	LOG	0.	0.
	USER	0.	0.

READERS CONFIGURATION

Edit	Reader	Port	Physical address	Pump	Online	Error
	1	DISP	1 address	0	✓	
	2	0.	0.	0		
	3	0.	0.	0		
	4	0.	0.	0		
	5	0.	0.	0		
	6	0.	0.	0		

Configuration of ports includes setting of communication protocol and baud rate for each of the ports and also assigning the readers to each of the ports. Each of the readers should be also assigned a specific pump or otherwise can be set to serve any pump if value is set to 0 for field *Pump*:

The 'Edit record' dialog box is shown, allowing for the configuration of a specific reader. It includes the following fields:

- Reader port:
- Communication address:
- Pump:

An 'Update' button is located at the bottom right of the dialog.

Readers configuration table also displays readers' statuses (online state and errors present in communication using icons).

Also, same page contains configuration of the tags, which can be used by fuel attendants or corporate customers:

The screenshot shows the 'TAGS LIST' configuration page in the PTS-2 controller web interface. The page header includes 'PTS-2 controller ver. 2021.12.04 22:32:14' and 'admin Logout'. The main content area features a 'TAGS LIST' section with a file upload area and a table of tag records.

Tags list file: **TAGS.CSV**: 93 B ([download](#))

Upload new file:

Select file

Automatically read a tag by the reader

Reader 1

Search:

ID	Name	Valid
000000140027e917	Johny Great	Yes
1122334455667788	Will Smith	No
9900AABBCCDDEEFF	Mr. Black	Yes

Previous Next

PTS-2 controller developed by [Technotrade LLC](#)

Each tag configuration contains entering tag ID, tag holder name and validity flag:

Edit record

ID:

Name:

Valid: Yes No

List of tags is stored in file *Tags.csv* on SD flash disk. It can be downloaded from this page and also uploaded.

NOTE! Structure of tags list file is described in section [Files stored on SD flash disk](#).

Additionally, option *Automatically read a tag by the reader* allows to select a reader from a list and to automatically read the tag identifier by the selected reader when adding or editing the tags.

Wireless tab

This tab allows to configure which ports of the PTS-2 controller are to be set for wireless communication when working through WFC (wireless forecourt communication) boards. Here you need to select the ports using wireless communication and to assign each of the devices configured to such ports values of IP-address and port for each of the WFC boards.

The screenshot shows the 'Wireless' configuration page in the PTS-2 controller interface. The page has a dark sidebar on the left with various icons. At the top, it says 'PTS-2 controller ver. 2023.04.15 16:52:28' and 'admin Logout'. Below the sidebar is a 'Configuration' bar with tabs for Settings, Pumps, Probes, Parameters, Grades, Tanks, Nozzles, Boards, Readers, **Wireless**, and Users. Underneath are 'Get' and 'Set' buttons. The main content area is divided into two sections:

PORTS CONFIGURATION

Edit	Port	Wireless communication
	1	<input checked="" type="checkbox"/>
	USER	<input type="checkbox"/>
	DISP	<input type="checkbox"/>

DEVICES CONFIGURATION

Edit	Type	No.	Port	IP-address	Port
	Pump	1	1	192.168.1.201	3333
	Pump	2	1	192.168.1.202	3333
	Pump	3	1	192.168.1.203	3333
	Pump	4	1	192.168.1.204	3333
	Pump	5	1	192.168.1.205	3333

Users tab

This tab allows to configure a list of users and their permissions for access to the PTS-2 controller web server. Also, credentials of the user used for communication to a remote server is configured here.

The screenshot shows the 'Users' configuration page in the PTS-2 controller web interface. The page title is 'PTS-2 controller' with version 'ver. 2023.04.15 16:52:28' and a user 'admin' is logged in. The navigation menu includes 'Settings', 'Pumps', 'Probes', 'Parameters', 'Grades', 'Tanks', 'Nozzles', 'Boards', 'Readers', 'Wireless', and 'Users'. The 'Users' tab is selected, showing a table with columns for 'Edit', 'No.', 'Login', and 'Permissions' (Configuration, Control, Monitoring, Reports view). The table lists 10 users, including 'admin', 'reports', 'service', 'POS', and 'Server', with their respective permission settings indicated by toggle switches.

Edit	No.	Login	Permissions			
			Configuration	Control	Monitoring	Reports view
	1	admin	<input checked="" type="checkbox"/>	<input checked="" type="checkbox"/>	<input checked="" type="checkbox"/>	<input checked="" type="checkbox"/>
	2	reports	<input type="checkbox"/>	<input type="checkbox"/>	<input type="checkbox"/>	<input checked="" type="checkbox"/>
	3	service	<input checked="" type="checkbox"/>	<input type="checkbox"/>	<input checked="" type="checkbox"/>	<input checked="" type="checkbox"/>
	4	POS	<input type="checkbox"/>	<input checked="" type="checkbox"/>	<input checked="" type="checkbox"/>	<input checked="" type="checkbox"/>
	5	Server	<input checked="" type="checkbox"/>	<input checked="" type="checkbox"/>	<input checked="" type="checkbox"/>	<input type="checkbox"/>
	6		<input type="checkbox"/>	<input type="checkbox"/>	<input type="checkbox"/>	<input type="checkbox"/>
	7		<input type="checkbox"/>	<input type="checkbox"/>	<input type="checkbox"/>	<input type="checkbox"/>
	8		<input type="checkbox"/>	<input type="checkbox"/>	<input type="checkbox"/>	<input type="checkbox"/>
	9		<input type="checkbox"/>	<input type="checkbox"/>	<input type="checkbox"/>	<input type="checkbox"/>
	10		<input type="checkbox"/>	<input type="checkbox"/>	<input type="checkbox"/>	<input type="checkbox"/>

PTS-2 controller developed by Technotrade LLC

NOTE! Under a user it is understood not obligatory a human being, but also it means credentials, under which remote control systems (POS, cash register, payment system server, mobile application, OPT, servers of data analysis, etc.) can communicate with PTS-2 controller. Each user is to be set a list of permissions:

- configuration
- control
- monitoring
- reports' view

NOTE! It is strictly recommended that each separate management system uses its own independent configured user.

Pumps control page

Pumps control page allows to monitor all pumps and provide control over them.

There are 2 views for this page:

- view pumps as widgets
- view pump in a form of a table

Pumps widgets

Pumps can be displayed as pump widgets showing all information on each pump:

The screenshot shows the 'Pumps control' interface for the PTS-2 controller. The page title is 'PTS-2 controller ver. 2021.12.04 22:32:14' and the user is logged in as 'admin'. The interface displays seven pump widgets arranged in a grid. Each widget shows the pump's current state (NOZZLE, FILLING, or IDLE), along with 'Amount', 'Volume', and 'Price' values. A 'Nozzle' dropdown menu is present for each pump, and 'Start' and 'Stop' buttons are provided for control. The pump states are: 1. NOZZLE, 2. FILLING, 3. IDLE, 4. NOZZLE, 5. FILLING, 6. IDLE, 7. IDLE. A 'Select view' dropdown is located in the top right corner of the widget area.

The widget allows to display following information for the pump:

- pump state (IDLE, NOZZLE, FILLING, OFFLINE)
- values of volume, amount and price for present filling or last dispensing made
- selected fuel grade and nozzle
- indication a name of user, which sent a request to the pump
- button *Start* for starting a filling with preset of order (in volume, amount or up to a full tank (allows to preset from dispenser keyboard))
- button *Stop* for stopping the filling

When the user clicks on *Start* button – a dialog for preset of order is opened:

The 'Confirm start?' dialog box is shown with a yellow header and a close button (X). It contains the following fields and controls:

- Pump:** A text field containing the value '1'.
- Nozzle:** A dropdown menu currently showing 'Petrol (1.23)'.
- Type:** A dropdown menu currently showing 'Amount'.
- Dose:** A text field containing the value '20'.
- Keypad:** A numeric keypad with buttons for digits 1-9, a decimal point, 0, and a backspace key (X).
- Buttons:** A green 'Start' button and a red 'Cancel' button at the bottom.

Pumps table

Pumps can be also displayed in a form of table with detailed information on each pump:

The screenshot shows the 'Pumps control' interface. At the top, there's a header with 'PTS-2 controller ver. 2021.12.04 22:32:14' and a user profile 'admin Logout'. Below the header is a 'Pumps control' section with a 'Select view' dropdown. The main part is a table with columns: Pump, Status, Nozzle, Price, Filled volume, Filled amount, Total volume, Total amount, User, and Request. The table contains 7 rows of pump data. Below the table, there are controls for selecting a pump (currently '1'), preset type ('Volume'), and preset dose ('1.00'). A list of nozzles is shown with radio buttons and their respective prices. To the right of the nozzle list are several control buttons: 'Authorize' (green), 'Stop' (red), 'Resume' (cyan), 'Suspend' (yellow), and 'EMERGENCY STOP' (red). Further right are buttons for 'Get prices', 'Set prices', 'Get total counters', 'Get tag ID', 'Turn lights on', and 'Turn lights off'.

Pump	Status	Nozzle	Price	Filled volume	Filled amount	Total volume	Total amount	User	Request
1	NOZZLE	1 (Petrol)	1.11	8.40	12.18	0.00	0.00		
2	FILLING	2 (Diesel)	1.05	57.20	60.06	0.00	0.00	admin	
3	IDLE	0	1.11	0.00	0.00	0.00	0.00		
4	NOZZLE	4	0.00	0.00	0.00	0.00	0.00		
5	FILLING	1 (Petrol)	1.11	54.80	60.83	0.00	0.00	admin	
6	IDLE	0	1.11	0.00	0.00	0.00	0.00		
7	IDLE	0	1.11	0.00	0.00	0.00	0.00		

This user interface has additional buttons for provision of complete control over pumps:

- authorize a pump with preset (volume, amount) or to full tank
- stop a filling
- suspend and resume a filling
- get total counter
- set and get prices
- get tag identifier (in case if pump supports)
- set on/off lights (in case if pump supports)

Preset type field allows preset order in volume and amount and full tank (allows to preset from dispenser keyboard).

The screenshot shows a 'Confirm authorization' dialog box with a yellow header and a close button (X). The dialog contains the following information: 'Pump: 1', 'Nozzle: 1 (Petrol)', 'Price: 1.23', 'Preset type: Amount', and 'Dose: 20.00'. At the bottom, there are two buttons: 'Start' (green) and 'Cancel' (red).

Tanks monitoring page

Tanks monitoring page allows to monitor all tanks and petroleum products parameters, measured by the probes. List of displayed parameters depend on the type of probes used and measurements it provides.

The screenshot shows the 'Tanks monitoring' page in the PTS-2 controller interface. The page title is 'Tanks monitoring' and the user is logged in as 'admin'. There are three tank widgets:

- 1 Petrol:** 95% full. Parameters: Product height 940 mm, Product volume 20000 L, Product TC volume 19900 L, Product ullage 1000 L, Water height 20 mm, Water volume 200 L, Temperature 24.7 °C, Product density 759 kg/m³, Product mass 1500 kg.
- 2 Diesel:** 57% full. Parameters: Product height 1000 mm, Product volume 20000 L, Product TC volume 19900 L, Product ullage 15000 L, Water height 10 mm, Water volume 100 L, Temperature 20 °C, Product density 759 kg/m³, Product mass 15200 kg.
- 3 LPG:** 1% full. Parameters: Product height 50 mm, Product volume 300 L, Product TC volume 300 L, Product ullage 25400 L, Water height 0 mm, Water volume 0 L, Temperature 19.7 °C, Product density 559 kg/m³, Product mass 100 kg. A red warning icon is present in the top right corner of this widget.

At this tank widget will show if there is any alert registered for tank, for example:

This image shows a close-up of the Diesel tank widget (labeled '2 Diesel') with a 1% fill level. A red alarm notification box is overlaid on the widget, displaying the text 'Alarm!' and 'Low product alarm registered!'.

Parameters for the Diesel tank shown:

- Product height: 90 mm
- Product volume: 366 L
- Product TC volume: 364 L
- Product ullage: 49039 L
- Water height: 0 mm
- Water volume: 0 L
- Temperature: 20.3 °C
- Product density: 850 kg/m³
- Product mass: 311.1 kg

In case if there are several alerts preset – all of them will be shown as a list.

In case if automatic registration of in-tank deliveries is activated in parameters for probe – then information on the last registered in-tank delivery is displayed on the tank widget:

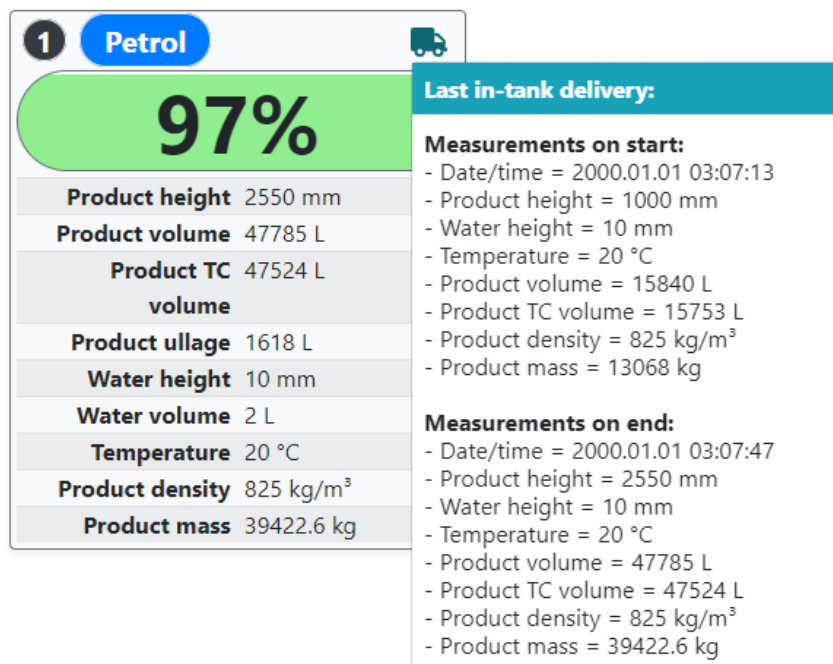

In parameters for each of the probes it is possible to configure different settings, for example:

- probe offset from a tank's bottom
- automatic calculation of product volume based on tank's calibration chart
- automatic calculation of product temperature compensated volume
- automatic registration of in-tank deliveries
- automatic calculation of product mass
- automatic check of alarms
- others

See more details in [Probe parameters](#) section.

Reporting page

Reporting pages allows to generate and view reports for:

- pumps sales
- tanks measurements
- in-tank deliveries
- tanks reconciliation (comparison of fuel movements in tanks with pumps sales)
- GPS records
- alert records

PTS-2 controller
ver. 2023.04.15 16:52:28

admin
Logout

Reporting

Pumps Tanks Pumps and tanks reconciliation GPS Alerts Report files

Pump All

Date/time start 04.04.23 00:00:06

Date/time end 05.04.23 00:00:06

Fuel grade All

User All

Generate report

FUEL GRADES SUMMARY SALES REPORT FOR ALL PUMPS FROM 04.04.23 00:00:06 TILL 05.04.23 00:00:06, DEVICE ID: 003F003E3034511631323737

Copy Excel CSV Print

Search:

#	Fuel grade	Price	Filled volume, L	Filled amount
1	Diesel	58.85	521.998	30720.00
2	Diesel	59.35	2122.384	115967.23
3	Diesel	61.85	22.634	1400.00
4	Diesel	62.35	488.477	30457.36

Reports can be generated and viewed in case if the PTS-2 controller is configured to save records in database, which is configured in parameters of PTS-2 controller (please see section [PTS-2 controller parameters](#)). Other important thing is that clock in the PTS-2 controller should be configured to lead current time, which is set on [Configuration](#) page > [Settings](#) tab, because each record is stored with specification of time. Also, presence of battery on the board of PTS-2 controller is necessary to keep the time when PTS-2 controller is powered off.

Reports include filters, which allow to find the data more precisely:

- pump or tank number
- date and time of period start
- date and time of period end
- fuel grade (for pumps only)
- user, which made the pump transaction (for pumps only)
- tag ID of the fuel attendant servicing the sale or a corporate customer (if case of readers application) (for pumps only)

Also, you can export generated report data to CSV and Excel files, copy or print.

Pumps tab

On this tab you can generate reports for pumps transactions performed.

Records can be filtered on:

- pump number
- date and time of period start
- date and time of period end
- fuel grade
- user, which made the pump transaction
- tag ID of the fuel attendant servicing the sale or a corporate customer (if case of readers application)

Once a report is requested to be generated – then it will show 3 reports:

1. **FUEL GRADES SUMMARY SALES REPORT** – this report calculates summary sales of each fuel grade separating the sales done with different price, for example:

FUEL GRADES SUMMARY SALES REPORT FOR ALL PUMPS FROM 04.04.23 00:00:06 TILL 05.04.23 00:00:06, DEVICE ID: 003F003E3034511631323737				
Copy		Excel	CSV	Print
				Search: <input type="text"/>
#	Fuel grade	Price	Filled volume, L	Filled amount
1	Diesel	58.85	521.998	30720.00
2	Diesel	59.35	2122.384	115967.23
3	Diesel	61.85	22.634	1400.00
4	Diesel	62.35	488.477	30457.36
5	Premium	63.20	41.910	2649.28
6	Premium	64.60	655.356	42349.62
7	Premium	66.20	9.213	610.00
8	Premium	67.60	41.323	2793.98
9	Regular	62.30	63.075	3930.06
10	Regular	63.69	354.943	22607.15
11	Regular	63.70	1255.014	79959.10
12	Regular	65.30	1.531	100.00
13	Regular	66.70	136.706	9119.20
Total:			5714.564	342662.98

2. **PUMPS TRANSACTIONS REPORT** – this report shows a detailed result of each pump sale performed, for example:

PUMPS TRANSACTIONS REPORT FOR ALL PUMPS FROM 04.04.23 00:00:06 TILL 05.04.23 00:00:06, DEVICE ID: 003F003E3034511631323737

Copy Excel CSV Print

Show 10 entries Search:

#	Date/time start	Date/time end	Pump	Nozzle	Transaction	Price	Filled volume, L	Filled amount	Volume totals, L	Amount totals	User
1	2023.04.04 00:04:31	2023.04.04 00:05:56	9	1 (Diesel)	6647	58.85	25.488	1500.00	97359.809	6315537.08	PTS
2	2023.04.04 00:07:00	2023.04.04 00:07:38	8	1 (Regular)	20272	62.30	3.662	228.14	64728.016	4258621.57	PTS
3	2023.04.04 00:16:47	2023.04.04 00:17:10	11	1 (Regular)	9279	62.30	1.605	100.00	50436.970	3303983.48	PTS
4	2023.04.04 00:18:20	2023.04.04 00:19:22	10	1 (Diesel)	8597	58.85	16.992	1000.00	148213.098	9572737.93	PTS
5	2023.04.04 00:29:23	2023.04.04 00:29:39	8	1 (Regular)	20273	62.30	1.123	70.00	64729.139	4258691.57	PTS
6	2023.04.04 00:30:53	2023.04.04 00:31:16	8	1 (Regular)	20274	62.30	1.605	100.00	64730.744	4258791.57	PTS
7	2023.04.04 00:37:14	2023.04.04 00:37:31	8	1 (Regular)	20275	62.30	0.802	50.00	64731.546	4258841.57	PTS
8	2023.04.04 00:45:33	2023.04.04 00:49:48	10	1 (Diesel)	8598	58.85	82.752	4870.00	148295.850	9577607.93	PTS
9	2023.04.04 00:49:45	2023.04.04 00:50:16	8	1 (Regular)	20276	62.30	2.407	150.00	64733.953	4258991.57	PTS
10	2023.04.04 00:54:11	2023.04.04 00:55:04	10	1 (Diesel)	8599	58.85	16.992	1000.00	148312.842	9578607.93	PTS
Total:							5714.564	342662.98			

Showing 1 to 10 of 969 entries Previous 1 2 3 4 5 ... 97 Next

Each recorded sale contains quite much details like:

- pump sale start date and time
- pump sale end date and time
- pump number
- nozzle number
- fuel grade ID
- transaction number
- pump price
- dispensed volume
- dispensed temperature-compensated volume (volume converted to 15 degrees Celsius)
- dispensed money amount
- value of volume counter in pump on the transaction end
- value of money amount totalizer counter in pump on the transaction end
- value of customer or fuel attendant tag applied for the transaction (the fuel attendant ID card to authorize the pump or the customer's discount/loyalty card)
- ID of a management system authorizing a pump (local POS system or OPT)

3. **PUMPS NOZZLES SUMMARY REPORT** – this report shows summary sales by each of the pumps’ nozzles, for example:

PUMPS NOZZLES SUMMARY REPORT FOR ALL PUMPS FROM 04.04.23 00:00:06 TILL 05.04.23 00:00:06, DEVICE ID: 003F003E3034511631323737

Copy Excel CSV Print

Search:

#	Pump	Nozzle	Volume totals on start, L	Volume totals on end, L	Volume totals difference, L	Summary registered filled volume, L	Amount totals on start	Amount totals on end	Amount totals difference	Summary registered filled amount
+	1	1 (Premium)	28765.723	28964.009	198.286	193.033	1894775.28	1907651.02	12875.74	12536.33
+	2	1 (Regular)	58470.442	58827.125	356.683	346.481	3843552.00	3866351.01	22799.01	22149.01
+	3	1 (Diesel)	91004.810	91482.872	478.062	431.728	5874693.32	5903180.32	28487.00	25737.00
+	4	1 (Diesel)	142077.820	142744.359	666.539	659.800	9183364.10	9223115.63	39751.53	39351.53
+	5	1 (Regular)	72925.486	73392.892	467.406	455.950	4811021.78	4840914.01	29892.23	29162.23
+	6	1 (Premium)	27651.193	27834.016	182.823	179.342	1823320.76	1835140.62	11819.86	11594.86
+	7	1 (Premium)	33476.267	33728.627	252.360	252.360	2212475.34	2228791.94	16316.60	16316.60
+	8	1 (Regular)	64724.354	65364.590	640.236	630.002	4258393.43	4299207.83	40814.40	40162.41
+	9	1 (Diesel)	97334.321	97981.533	647.212	564.652	6314037.08	6353024.08	38987.00	34087.00
+	10	1 (Diesel)	148196.106	149711.709	1515.603	1499.313	9571737.93	9662073.80	90335.87	79369.06
+	11	1 (Regular)	50435.365	50808.484	373.119	358.836	3303883.48	3327761.54	23878.06	22968.06
+	12	1 (Premium)	15527.796	15620.863	93.067	93.067	998167.80	1004184.89	6017.09	6017.09
+	13	1 (Regular)	3772.030	3792.030	20.000	20.000	197960.82	199234.62	1273.80	1273.80
+	14	1 (Premium)	2774.662	2804.662	30.000	30.000	135097.62	137035.62	1938.00	1938.00
Total:					5921.396	5714.564	Total:		365186.19	342662.98

Also, in case if automatic readout of total counters is switched on in parameters for pumps (in configuration of the [Pump parameters](#)) – then here you can see starting and ending values for totals and their difference, this value is compared to total volume dispensed through pump nozzle – these values should match, if they do not match – then there were sales done while PTS-2 controller was disconnected.

Tanks tab

On this tab you can generate reports for tanks measurements with generation of chart.

Records can be filtered on:

- tank number
- date and time of period start
- date and time of period end

Tank level changes report displays all the registered changes of level in tank with details on all the measurements. A threshold for saving a new level is configured in parameters for the probe on [Configuration](#) page > [Probe parameters](#) tab:

PTS-2 controller
ver. 2022.09.25 21:40:31

admin
Logout

Reporting

Pumps Tanks Pumps and tanks reconciliation GPS Alerts Report files

Tank 1 (Petrol)

Date/time start 27.06.21 21:54:30

Date/time end 29.06.21 21:54:30

Generate report

TANK LEVEL CHANGES REPORT FOR TANK 1 (PETROL) FROM 27.06.21 21:54:30 TILL 29.06.21 21:54:30, DEVICE ID: 0054002E524E500420323442

Copy Excel CSV Print

Show entries Search:

#	Date/time	Product height, mm	Water height, mm	Temperature, °C	Product volume, L	Water volume, L	Product ullage, L	Product TC volume, L	Product density, kg/m ³	Product mass, kg
1	2021.06.27 22:00:30	2375	10	20	19000	100	6000	18896	759	14421
2	2021.06.27 23:50:00	2375	10	20	19000	100	6000	18896	759	14421
3	2021.06.28 00:00:30	2125	10	20	17000	100	8000	16907	759	12903
4	2021.06.28 05:50:00	2125	10	20	17000	100	8000	16907	759	12903
5	2021.06.28 06:00:30	2000	10	20	16000	100	9000	15912	759	12144

Tank level changes chart displays how the level was changed in the tank with time.

In-tank deliveries report shows all automatically registered fuel deliveries received in tank.

PTS-2 controller
ver. 2022.09.25 21:40:31
admin
Logout

5 06:00:30 2000 10 20 16000 100 9000 15912 759 12144

Showing 1 to 5 of 16 entries Previous 1 2 3 4 Next

TANK LEVEL CHANGES CHART FOR TANK 1 (PETROL) FROM 27.06.21 21:54:30 TILL 29.06.21 21:54:30, DEVICE ID: 0054002E524E500420323442

IN-TANK DELIVERIES REPORT FOR TANK 1 (PETROL) FROM 27.06.21 21:54:30 TILL 29.06.21 21:54:30, DEVICE ID: 0054002E524E500420323442

Copy Excel CSV Print

Show entries Search:

# ▲	Date/time start	Date/time end	Product height on start, mm	Product height on end, mm	Product volume on start, L	Product volume on end, L	Received product volume, L
0	2021.06.28 19:00:30	2021.06.28 19:50:00	125	2500	1000	20000	19000

Showing 1 to 1 of 1 entries Previous 1 Next

>> PTS-2 controller developed by Technotrade LLC
⬆

Pumps and tanks reconciliation tab

On this tab you can generate reports for tanks reconciliation.

Records can be filtered on:

- tank number
- date and time of period start
- date and time of period end

For making a tank reconciliation this report compares 2 things:

- fuel remains in tank on selected period start
- fuel in-tank deliveries in tank registered by measurement probe during selected period
- fuel fillings from tank registered by measurement probe during selected period
- fuel dispensing from tank registered by fuel dispensers during selected period
- actual fuel remains in tank on selected period end
- calculated fuel remains in tank on selected period end (accounts from sales from dispensers)

In normal situation the actual remains of fuel in tank should equal to calculated fuel remains in tank meaning that all the fuel dispensed from tank was sold through the pumps. If there is a significant difference between these values – then there can be leakages from the tank (or pipes) or frauds (stealing) of fuel.

The screenshot displays the 'PTS-2 controller' web interface. The top navigation bar includes 'Reporting', 'Pumps', 'Tanks', 'Pumps and tanks reconciliation' (selected), 'GPS', 'Alerts', and 'Report files'. The main content area shows a form for generating a report for 'Tank 1 (Petrol)' with a start date/time of '27.06.21 21:54:30' and an end date/time of '29.06.21 21:54:30'. A 'Generate report' button is visible. Below the form, the report title is 'TANK RECONCILIATION REPORT FOR TANK 1 (PETROL) FROM 27.06.21 21:54:30 TILL 29.06.21 21:54:30, DEVICE ID: 0054002E524E500420323442'. There are buttons for 'Copy', 'Excel', 'CSV', and 'Print'. The report data is presented in a table:

Tank	Fuel grade	Product volume on start, L	Summary increased volume, L	Summary decreased volume, L	Volume filled by pumps, L	Calculated product volume on end, L	Actual product volume on end, L	Difference between actual and calculated volumes, L
1	Petrol	19000	19000	18000	19000	19000	20000	1000

The footer of the interface shows 'PTS-2 controller developed by Technotrade LLC'.

In order to generate this report you should have pumps nozzles configured to tanks and fuel grades (this is done on [Configuration](#) page > [Nozzles](#) tab).

GPS tab

On this tab you can generate reports for GPS records registered.

Records can be filtered on:

- date and time of period start
- date and time of period end

Report on GPS records allows to see all the registered GPS records for the points, where PTS-2 controller was moving (in case if it is installed inside the fuel tankers). Distance between GPS coordinates for saving to database for reporting is configured in parameters for the PTS-2 controllers on [Configuration](#) page > [Parameters](#) tab.

The screenshot shows the 'Reporting' section of the PTS-2 controller interface. The 'GPS' tab is selected. The 'Date/time start' is set to 27.06.21 11:54:30 and 'Date/time end' is 29.06.21 21:54:30. A 'Generate report' button is visible. Below this, a table titled 'GPS COORDINATES REPORT FROM 27.06.21 11:54:30 TILL 29.06.21 21:54:30, DEVICE ID: 0054002E524E500420323442' is displayed. The table has columns for #, Date/time, Latitude, North/South, Longitude, East/West, Speed over ground, Course over ground, and Mode. The first five rows of data are shown, all with 'Autonomous' mode. A search bar and pagination controls are also present.

#	Date/time	Latitude	North/South	Longitude	East/West	Speed over ground	Course over ground	Mode
1	2021.06.27 16:12:18	5029.0000	North	03029.0000	East	14	116.01	Autonomous
2	2021.06.27 16:15:59	5029.9114	North	03029.8710	East	1.37	312.52	Autonomous
3	2021.06.27 16:16:52	5029.9141	North	03029.8820	East	0.53	0	Autonomous
4	2021.06.27 16:17:08	5029.9160	North	03029.8471	East	0.56	0	Autonomous
5	2021.06.27 17:28:36	5029.9133	North	03029.8838	East	0.28	296.52	Autonomous

Alerts tab

On this tab you can generate reports for all registered alert records showing start and end of each alert.

Records can be filtered on:

- date and time of period start
- date and time of period end

Report on alert allows to see all the registered alert records for the PTS-2 controller, pumps, probes/tanks, price boards and readers. Reports are generated from saved alerts, option for saving alerts is configured in parameters for the PTS-2 controllers on [Configuration](#) page > [Parameters](#) tab.

The screenshot displays the 'Reporting' section of the PTS-2 controller interface. It features a navigation bar with options like 'Pumps', 'Tanks', 'Pumps and tanks reconciliation', 'GPS', 'Alerts', and 'Report files'. The 'Alerts' tab is active, showing a filter for 'Date/time start' (23.09.22 22:44:20) and 'Date/time end' (27.09.22 22:44:20). Below the filter is a 'Generate report' button. The main area shows an 'ALERTS REPORT FROM 23.09.22 22:44:20 TILL 27.09.22 22:44:20, DEVICE ID: 0054002E524E500420323442'. There are buttons for 'Copy', 'Excel', 'CSV', and 'Print'. A search bar and a 'Show' dropdown are also present. The table below lists 5 alert entries:

#	Date/time	Device type	Device number	State	Description
1	2022.09.24 21:46:47	PTS	0	Start	Low battery voltage detected
2	2022.09.24 21:46:47	PTS	0	End	Low battery voltage detected
3	2022.09.24 21:50:21	Probe	2	Start	Offline state detected
4	2022.09.24 21:50:26	Probe	2	End	Offline state detected
5	2022.09.24 21:51:32	Probe	1	Start	Error detected

Showing 1 to 5 of 15 entries. Navigation: Previous 1 2 3 Next

Report files tab

This tab allows to download, delete and upload the report files. You can always upload previously downloaded report file.

The screenshot displays the 'PTS-2 controller' web interface. The top header shows the application name and version (2022.09.25 21:40:31) on the left, and the user 'admin' with a 'Logout' link on the right. A navigation menu on the left side contains icons for various system functions. The main content area is titled 'Reporting' and features a horizontal menu with tabs for 'Pumps', 'Tanks', 'Pumps and tanks reconciliation', 'GPS', 'Alerts', and 'Report files'. The 'Report files' tab is active, showing a list of report files with their names, sizes, and download/delete links:

- 1. **ALERTS.CSV**: 559 B ([download](#), [delete](#))
- 2. **GPSRECS.CSV**: 885 B ([download](#), [delete](#))
- 3. **PUMPTRN.CSV**: 1328 B ([download](#), [delete](#))
- 4. **TANKDLV.CSV**: 497 B ([download](#), [delete](#))
- 5. **TANKMSR.CSV**: 2416 B ([download](#), [delete](#))

Below the list, there is an 'Upload new report file:' section with a file input field and a 'Browse' button. A green success message 'Report file uploaded successfully!' is displayed above a progress bar that is at 100%.

The footer of the interface shows '>>' and 'PTS-2 controller developed by Technotrade LLC'.

Logging

Logging page allows to record a log of the PTS-2 controller communication with connected devices through one of its ports. The logging procedure is often useful in order to track possible problems in communication and fix them.

Procedure of taking a log includes the following steps:

1. Make sure that clock in PTS-2 controller is configured correctly, this is done on [Configuration](#) page > [Settings](#) tab. You can see the current date and time in *Current date/time* field
2. In field *Port* select the port, which connects to the equipment, communication with which you want to log, for example:

3. In field *Date/time to stop* set date and time, when the log should be stopped, this date and time should be later than the current date and time displayed in field *Current date/time*. The log will be automatically stopped when this time is reached.
4. Click *START* button to start logging.
5. To manually stop the logging process click on *STOP* button.

The screenshot shows the 'Logging' section of the PTS-2 controller interface. At the top left, it says 'PTS-2 controller ver. 2023.04.16 16:40:31'. At the top right, there is a user profile for 'admin' with a 'Logout' link. The main content area has a green header 'Logging'. Below it are three input fields: 'Current date/time' with the value '16.04.23 16:47:01', 'Port' with a dropdown menu showing 'Pump port 1 (Tatsuno SS-LAN)', and 'Date/time to stop' with the value '17.04.23 16:47:40'. A red 'STOP' button is centered below these fields. Underneath the button, a gear icon indicates 'Logging process is running...'. Two links are provided: 'Existing log-file: PORTLOG.BIN: 1508 B (download)' and 'Previous log-file: _PORTLOG.BIN: 24865 B (download)'. At the bottom left of the interface, there is a '>>' button and the text 'PTS-2 controller developed by Technotrade LLC'.

This page is refreshed automatically within several seconds and updates information about the generated log file size. The page shows the currently taken log and also a previous log (accumulated at previous logging process).

Generated log can be downloaded from this page. During the logging process a file named *PortLog.bin* is generated in a root of the SD flash card. If you download it through a web browser – then the downloaded file will be automatically assigned a name in format *PORTLOG_YYYY_MM_DD_HH_mm_SS.BIN*, where:

- YYYY – year
- MM – month
- DD – date
- HH – hours
- mm – minutes
- SS – seconds

These fields mean the date and time, when the log started, so that it is easy to understand what period it covers. For example, if the log-file is named *PORTLOG_2021_07_08_11_29_23.BIN* then it means that it started on 8th of July, 2021 at 11:29:23.

The log is accumulated in encrypted form, so once the log is recorded – it is required to pass obtained log-file to Technotrade LLC company for examining and elimination of possible problems, for reasons of which it was taken. When sending such a log-file please remember to additionally inform about all additional details, which could be helpful to find the problem and solve it like:

- device protocol and address
- exact time of the problem in log
- detailed problem description
- other observations, which could be useful to find a problem and understand its reason

Self-diagnostics page

Self-diagnostics page allows to check operation of all the peripheral components of the PTS-2 controller board including:

- ports with RS-485 interface: pump ports and DISP (RS-485) port
- ports with RS-232 interface: DISP (RS-232), LOG, USER, PC, EXT (for GPS module) and DEBUG
- DIP-switch
- SD flash disk
- battery
- CPU
- real-time clock

In order to perform self-diagnostics you need to use additional cabling for the ports, a scheme of connections of the PTS-2 controller board should be the following:

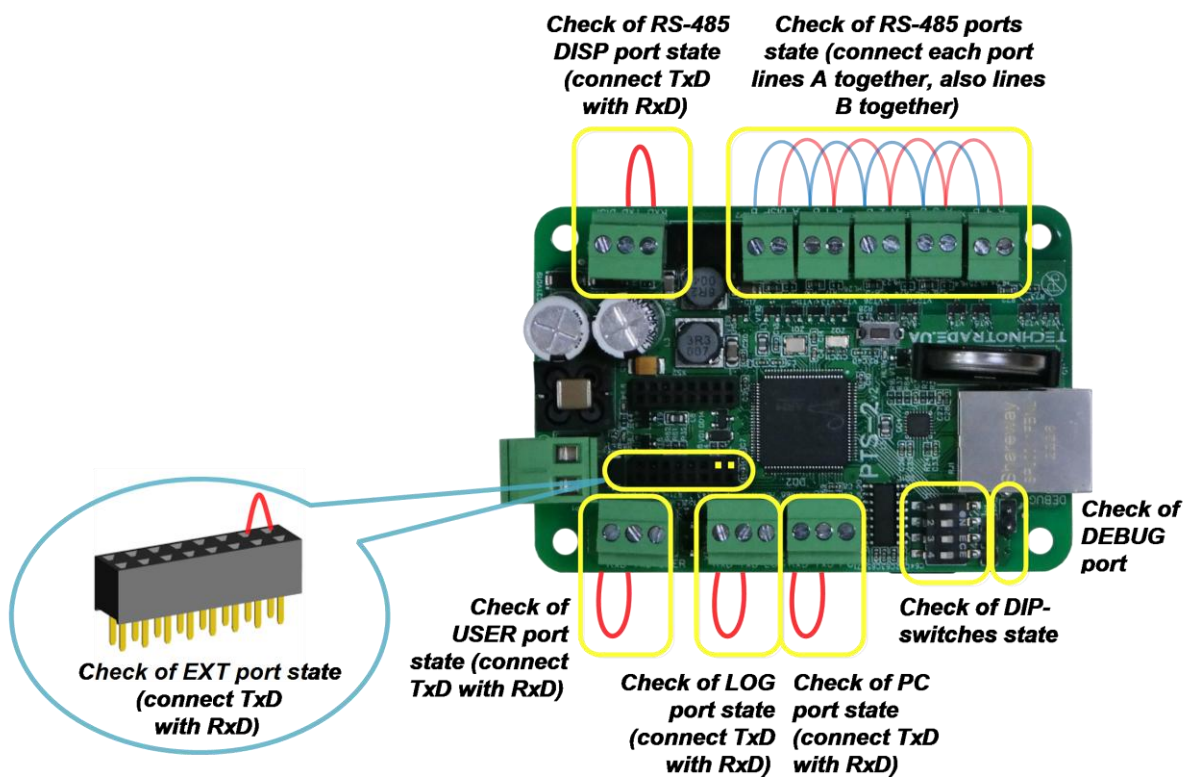

Lines “RS-485 A” in of each pump port and *DISP port (RS-485)* should be interconnected with each other, also lines “RS-485 B” in of each pump port and *DISP port (RS-485)* should be interconnected with each other as shown on the picture.

In *PC*, *LOG*, *USER* and *DISP (RS-232)* ports pin *TxD* should be shortened with pin *RxD* as shown on the picture.

In order to check operation of *DEBUG* port connect it to a COM-port terminal as it is described in section [DEBUG PORT](#). The *DEBUG* port is sending test messages while making diagnostics procedure.

Results of diagnostics is shown by color of labels. Green color means that correspondent component is working correctly (OK), red color – correspondent port is working incorrectly (Error).

PTS-2 controller
ver. 2022.12.27 17:32:50
admin
Logout

Self diagnostics

RS485_PORTS_STATE

For diagnostics of RS-485 ports:

- short close lines A of each RS-485 ports with each other
- short close lines B of each RS-485 ports with each other

Transmitting ports	Receiving ports				
Pump port 1	-	2	3	4	DISP
Pump port 2	1	-	3	4	DISP
Pump port 3	1	2	-	4	DISP
Pump port 4	1	2	3	-	DISP
DISP port	1	2	3	4	-

RS-232_PORTS_STATE

For diagnostics of RS-232/TTL ports short close with each other lines Tx and Rx in each RS-232/TTL port

Ports	States
PC port	OK
DISP port	OK
USER port	OK
LOG port	OK
EXT port	OK

SD FLASH DISK STATE

State	OK
-------	----

REALTIME CLOCK STATE

Present date/time	01.01.00 00:06:21
-------------------	-------------------

BATTERY STATE

Battery voltage	OK (3.010 mV)
-----------------	---------------

CPU STATE

CPU temperature	OK (37 °C)
-----------------	------------

DIP-SWITCHES STATE

DIP-switches	States
1	On
2	On
3	Off
4	Off

PTS-2 controller developed by [Technotrade LLC](#)

www.technotrade.ua

page 59 from 232

Firmware update page

PTS-2 controller firmware is constantly being improved and new versions of firmware with new added communication protocols and fixed bugs of the previous firmware versions are applied. New versions of PTS-2 controller's firmware are always available for downloading for customers.

Firmware update page allows to update firmware of PTS-2 controller. For this you should select path to *c_pts2.bin* file (for the PTS-2 PRO controller the firmware file is *c_pts2p.bin*). At this firmware is saved to the SD flash disk and is automatically updated on the PTS-2 controller restart, which is automatically done after the file upload is finished. After firmware update the web-server is automatically switched to *Device information* page to display currently installed firmware version. Firmware update process normally takes less than 1 minute.

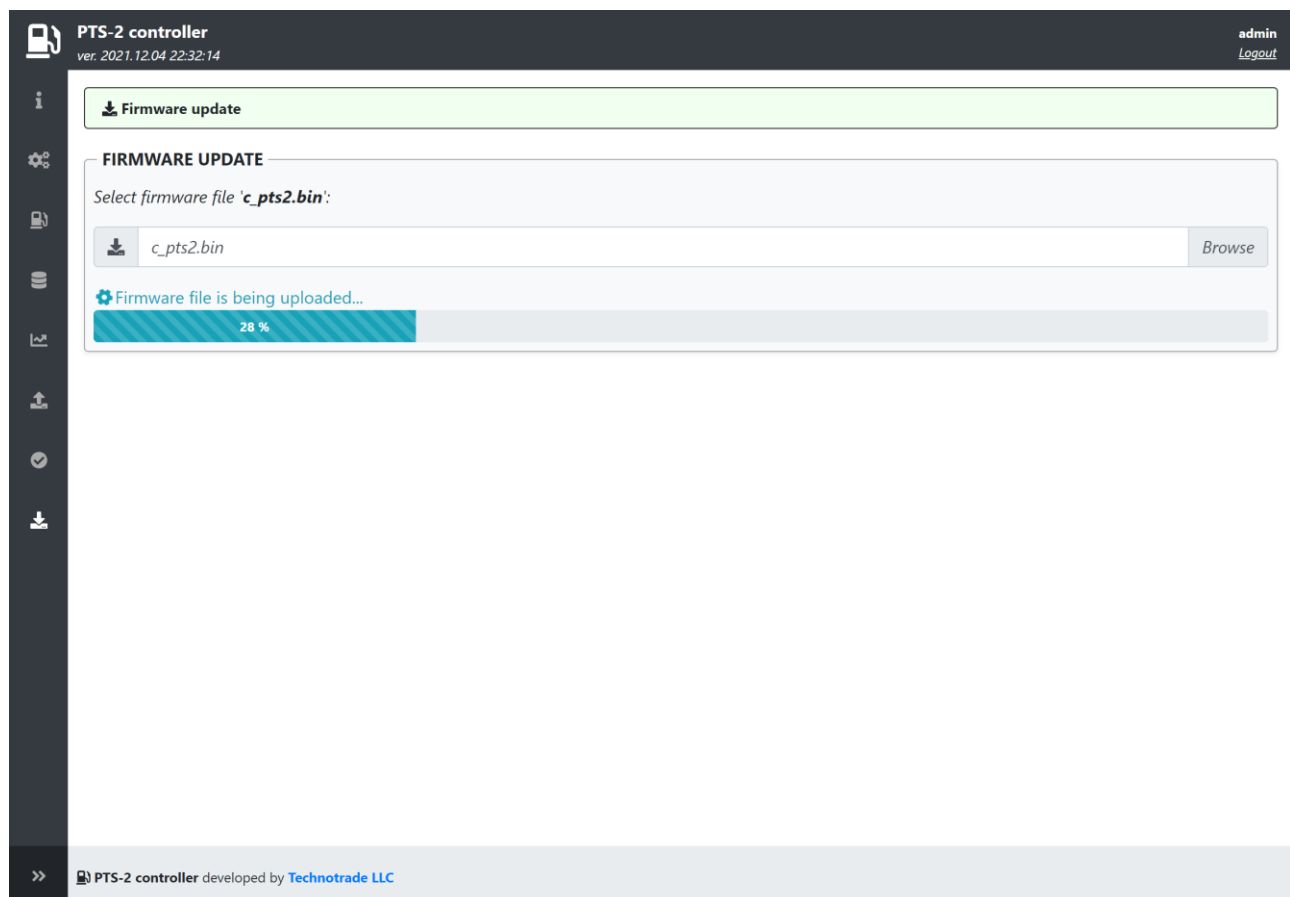

In case if it is needed to update the PTS-2 controller firmware and there is no access to the web-server – then it is needed to place *c_pts2.bin* firmware file (for the PTS-2 PRO controller the firmware file is *c_pts2p.bin*) to root of the SD flash disk and power on the PTS-2 controller. Firmware is updated on start-up.

After firmware update process is finished the used firmware file is automatically deleted from the SD flash disk. In case if the firmware file gets corrupted during the upload process – then this file is not applied and is automatically deleted on startup.

NOTE!

Some of the new firmware releases due to adding of new features might have the memory layout changed compared to previous versions of the firmware. Due to this after firmware update you might have

problems such as not being able to access the PTS-2 controller web-server or in general the PTS-2 controller not working. Due to this it is highly recommended to perform the following actions:

Before firmware update:

- make backup of the PTS-2 controller configuration, which you can do in PTS-2 controller web-server on [Configuration](#) page > [Settings](#) tab in *BACKUP/RESTORE CONFIGURATION* field and save the generated *Config.js* file somewhere on your computer for possible future usage for configuration restoring. Note that users' configuration is not saved and not restored to prevent any security loss, so you need to record the users' configuration manually (users' logins, passwords and permissions).
- save report files stored on the SD flash disk to your computer, you can download the report files from [Reporting](#) page > [Report files](#) tab. In a new firmware format of these files can be different resulting in an effect that after the firmware update attempt to generate reports from the database will result in faulty data or errors. In this case you need to delete the database files to allow the PTS-2 controller to generate the new files with a correct new format from start. Due to this before making the firmware update make sure that all your data from the PTS-2 controller is already saved.

If after the firmware update you are not be able to access the PTS-2 controller - please make the following:

- find 4-position DIP-switch on the board of PTS-2 controller and set:
 - DIP-1 switch: do not change
 - DIP-2 switch: do not change
 - DIP-3 switch set to ON position
 - DIP-4 switch set to ON position
- click *Restart* button on the board of PTS-2 controller
- after that you should be able to access PTS-2 controller using previous network parameters
- after that return both DIP-3 and DIP-4 switches back to OFF position

If even after using a combination with both DIP-3 and DIP-4 switches you are still not be able to access the PTS-2 controller - please make the [reset of the controller configuration](#) to default. After reset of the controller's configuration, you can restore the PTS-2 controller configuration from the *Config.js* file you saved previously and check that all the settings are set correctly. Note that users' configuration is not saved and not restored to prevent any security loss, so you need to record it manually.

BUILT-IN PUMPS SIMULATOR

PTS-2 controller firmware between its pump protocols has a protocol “37. Pump simulator”, which allows to simulate operation with the dispensers and to make easy debugging of control over dispensers without real fuel dispensers connected to the PTS-2 controller board. Baud rate for the pump port at this can be set to any possible.

The screenshot displays the PTS-2 controller web interface. The top navigation bar shows 'PTS-2 controller ver. 2023.04.16 23:45:59' and 'admin Logout'. The main navigation menu includes 'Settings', 'Pumps', 'Probes', 'Parameters', 'Grades', 'Tanks', 'Nozzles', 'Boards', 'Readers', 'Wireless', and 'Users'. The 'Pumps' section is active, showing two configuration tables.

Get Section: PUMP PORTS CONFIGURATION

Edit	Port	Protocol	Baud rate
	1	37. Pump simulator	4. 9600
	2	0. -----	0. -----
	3	0. -----	0. -----
	4	0. -----	0. -----

Set Section: PUMPS CONFIGURATION

Edit	Pump	Pump port	Physical address
	1	1 port	1 address
	2	1 port	2 address
	3	1 port	3 address
	4	1 port	4 address
	5	0 -----	0 -----
	6	0 -----	0 -----
	7	0 -----	0 -----
	8	0 -----	0 -----
	9	0 -----	0 -----
	10	0 -----	0 -----

Showing 1 to 10 of 50 entries

Previous 2 3 4 5 Next

Purpose of the pumps simulator protocol is to help developers in debugging of the control system software with the PTS-2 controller at absence of real dispensers or pumpheads connected.

Pumps simulator has a reach functionality for testing various aspects of the operation with dispensers:

- authorize a dispenser with preset for volume/amount values or without any preset
- simulate dispensing of fuel through this dispenser and stop it at necessity
- set prices to dispenser and get prices from dispenser
- read total counters values (both amount and volume) (total counters are lead on each of the nozzles separately and are dropped to zero at restart of the PTS-2 controller)
- set pause/suspend during dispensing and release/resume dispensing after pause
- simulate nozzle up state of the pump
- simulate filling state of the pump without any real filling (zero filling)
- simulate reading of the tag on a pump reader
- make immediate filling without a need to wait for long when filling big volumes

The pumps simulator protocol has a number of specific [pump parameters](#), which are configurable on [Configuration](#) page > [Parameters](#) tab. The list of parameters includes the following:

- immediate dispensing – allows to make the simulated filling almost immediately without a need to wait for long when big volumes sales are simulated
- nozzle up number – simulating of taking up a nozzle on a pump
- simulating tag presence on the pump in order to be able to request it and receive in response (useful when need to debug operation with the pump reader)
- simulating zero volume during filling – allows to simulate pump filling status when there is no fuel dispensed on the pump and close a transaction with zero volume and amount

The screenshot shows the 'Parameters' configuration page for a pump. The interface includes a top navigation bar with 'admin' and 'Logout' options. Below the navigation bar, there are tabs for 'Settings', 'Pumps', 'Probes', 'Parameters', 'Grades', 'Tanks', 'Nozzles', 'Boards', 'Readers', 'Wireless', and 'Users'. The 'Parameters' tab is active, and the 'Pump' device is selected. The configuration is divided into sections: '1. PUMP PROTOCOL SPECIFIC PARAMETERS' and '2. PUMP AUTHORIZATION SETTINGS'. The '1. PUMP PROTOCOL SPECIFIC PARAMETERS' section includes four parameters: '1.1. Immediate dispensing' (toggle off), '1.2. Nozzle up number' (input field with value 1), '1.3. Simulate tag presence' (toggle off), and '1.4. Simulate zero volume during filling' (toggle off). The '2. PUMP AUTHORIZATION SETTINGS' section includes '2.1. Automatically authorize pump on nozzle up' (toggle off).

Description	Default	Value
1. PUMP PROTOCOL SPECIFIC PARAMETERS		
1.1. Immediate dispensing Sets whether the dispensing should be done immediately on selected nozzle.	0	<input type="checkbox"/>
1.2. Nozzle up number Sets number of taken up nozzle.	0	<input type="text" value="1"/>
1.3. Simulate tag presence Sets automatic simulation of tag presence at pump reader.	0	<input type="checkbox"/>
1.4. Simulate zero volume during filling Sets simulation of zero volume while the filling is going (volume and amount are not increased during the filling).	0	<input type="checkbox"/>
2. PUMP AUTHORIZATION SETTINGS		
2.1. Automatically authorize pump on nozzle up Sets whether controller should automatically authorize pump on nozzle up detection. Authorization is done to	0	<input type="checkbox"/>

When the pumps are configured to use pump simulator protocol it is possible to see the pumps states on the [Pumps control](#) page and test operation there.

BUILT-IN PROBES SIMULATOR

PTS-2 controller firmware between its probes' protocols has a protocol "7. Probe simulator", which allows to simulate operation with the tank probes and to make easy debugging of monitoring over tanks without real ATG systems or probes connected to the PTS-2 controller board. Baud rate for the probe port at this can be set to any possible.

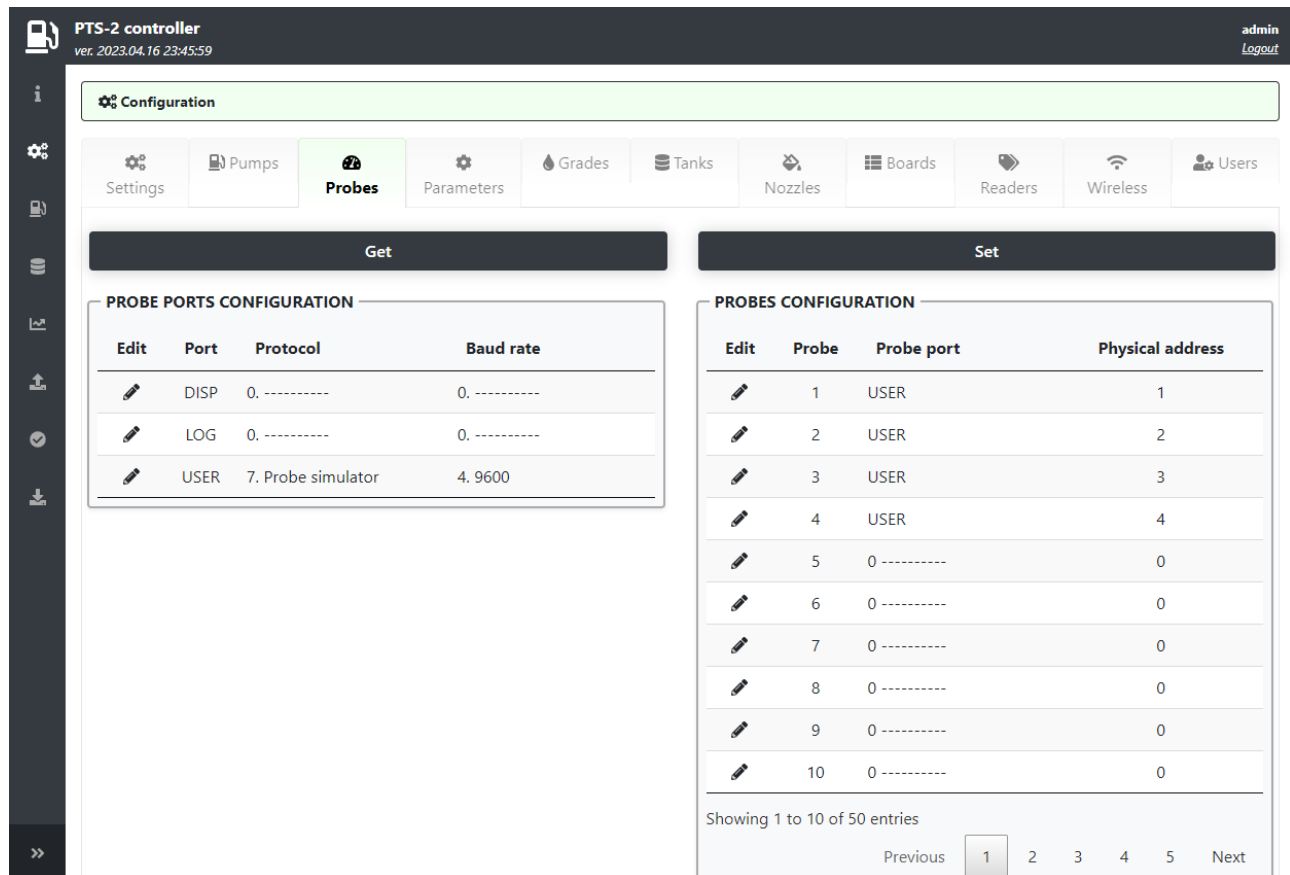

The screenshot shows the PTS-2 controller web interface. The top navigation bar includes 'Settings', 'Pumps', 'Probes', 'Parameters', 'Grades', 'Tanks', 'Nozzles', 'Boards', 'Readers', 'Wireless', and 'Users'. The 'Probes' section is active, showing two configuration tables.

PROBE PORTS CONFIGURATION (Get)

Edit	Port	Protocol	Baud rate
	DISP	0. -----	0. -----
	LOG	0. -----	0. -----
	USER	7. Probe simulator	4. 9600

PROBES CONFIGURATION (Set)

Edit	Probe	Probe port	Physical address
	1	USER	1
	2	USER	2
	3	USER	3
	4	USER	4
	5	0 -----	0
	6	0 -----	0
	7	0 -----	0
	8	0 -----	0
	9	0 -----	0
	10	0 -----	0

Showing 1 to 10 of 50 entries

Navigation: Previous 1 2 3 4 5 Next

Purpose of the probe simulator protocol is to help developers in debugging of the control system software with the PTS-2 controller at absence of real probes connected.

Probe simulator has a reach functionality for testing various aspects of the operation with probes:

- enable/disable presence of the simulated probe's measurements
- setting of simulated values for probe's measurements
- simulation of probe's error
- simulation of probe's in-tank delivery

The probes simulator protocol has a number of specific [probe parameters](#), which are configurable on [Configuration](#) page > [Parameters](#) tab.

The screenshot shows the 'PTS-2 controller' configuration page, version 2023.04.16, accessed at 23:45:59. The user is logged in as 'admin'. The page is titled '2. PROBE PROTOCOL SPECIFIC PARAMETERS' and lists 12 parameters for configuration. Each parameter includes a description, a numerical value, and a control element (toggle or input field).

Parameter ID	Description	Value	Control
2.1. Product level is present	Sets whether product level is present.	1	<input checked="" type="checkbox"/>
2.2. Product level value	Sets product level value in cm.	100	<input type="text" value="100"/>
2.3. Water level is present	Sets whether water level is present.	1	<input checked="" type="checkbox"/>
2.4. Water level value	Sets water level value in cm.	1	<input type="text" value="1"/>
2.5. Temperature is present	Sets whether temperature is present.	1	<input checked="" type="checkbox"/>
2.6. Temperature is negative	Sets whether temperature is negative.	0	<input type="checkbox"/>
2.7. Temperature value	Sets temperature value in 0.1 degree Celcius.	200	<input type="text" value="200"/>
2.8. Product volume is present	Sets whether product volume is present.	1	<input checked="" type="checkbox"/>
2.9. Product volume value	Sets product volume value in hundreds of units (liters, gallons, others).	200	<input type="text" value="200"/>
2.10. Water volume is present	Sets whether water volume is present.	1	<input checked="" type="checkbox"/>
2.11. Water volume value	Sets water volume value in hundreds of units (liters, gallons, others).	1	<input type="text" value="1"/>
2.12. Product temperature-compensated volume is present			<input type="checkbox"/>

When the probes are configured to use probe simulator protocol it is possible to see the tanks states on the [Tanks monitoring](#) page.

Example of tank calibration chart file NNALIB.CSV (NN – tank number):

```

000000000,000000000 CR LF
000000010,000000010 CR LF
000000030,000000020 CR LF
000000040,000000030 CR LF
000000050,000000040 CR LF
000000060,000000050 CR LF
000000080,000000060 CR LF
000000090,000000070 CR LF
000000100,000000080 CR LF
000000110,000000090 CR LF
000000130,000000100 CR LF

```

For example, in third line the file states that 3 mm level corresponds to 20 volume units (liters, gallons, other depending on the units used for account).

In order to prepare a tank calibration chart file with correct format you can use Microsoft Excel or any similar software. There are 3 things you should take care about:

1. Prepare the data in file: first value in each row is tank level in 0.1 mm, second value is volume in volume units (liters, gallons, other) corresponding to given level, for example:

	A	B
1	0	0
2	10	6
3	20	13
4	30	19
5	40	25
6	50	32
7	60	38
8	70	44
9	80	51
10	90	57
11	100	63

On this example image you can see in line 5 that height 4 mm corresponds to 25 volume units (liters, gallons, other).

2. Format cells to add leading zeros, so that totally you have 9 digits in each cell. This is possible to make if you set format type to 000000000 for each cell:

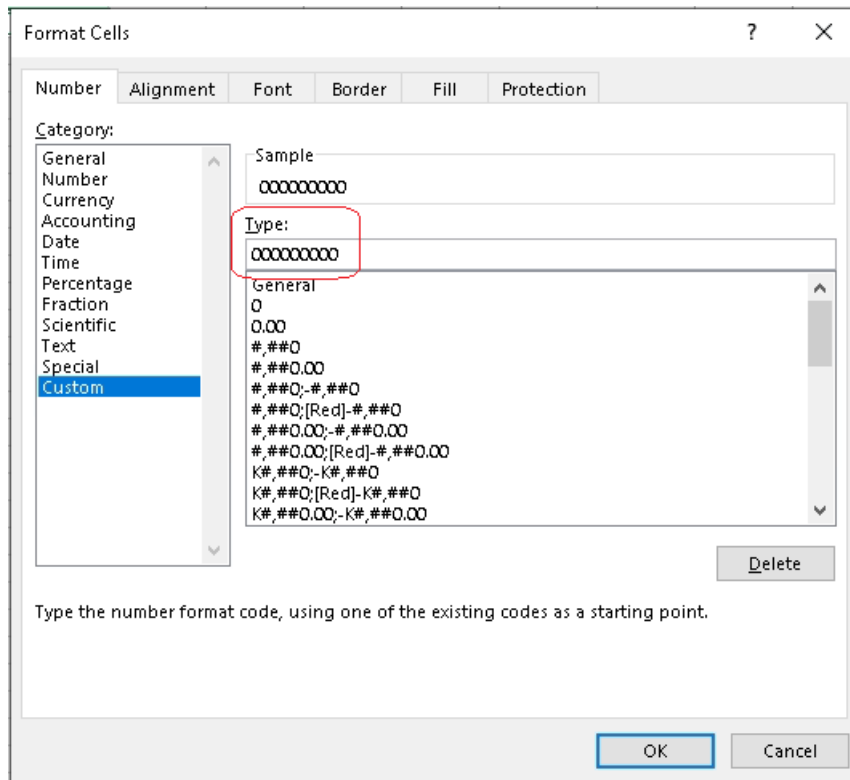

So, we have

	A	B
1	00000000	00000000
2	00000010	00000006
3	00000020	00000013
4	00000030	00000019
5	00000040	00000025
6	00000050	00000032
7	00000060	00000038
8	00000070	00000044
9	00000080	00000051
10	00000090	00000057
11	00000100	00000063

3. Save the created file in CSV format (comma separated values) for MS-DOS. Here MS-DOS format is needed in order to prevent putting a byte order mark in start of the document (please read about byte order mark preambula here: https://en.wikipedia.org/wiki/Byte_order_mark).

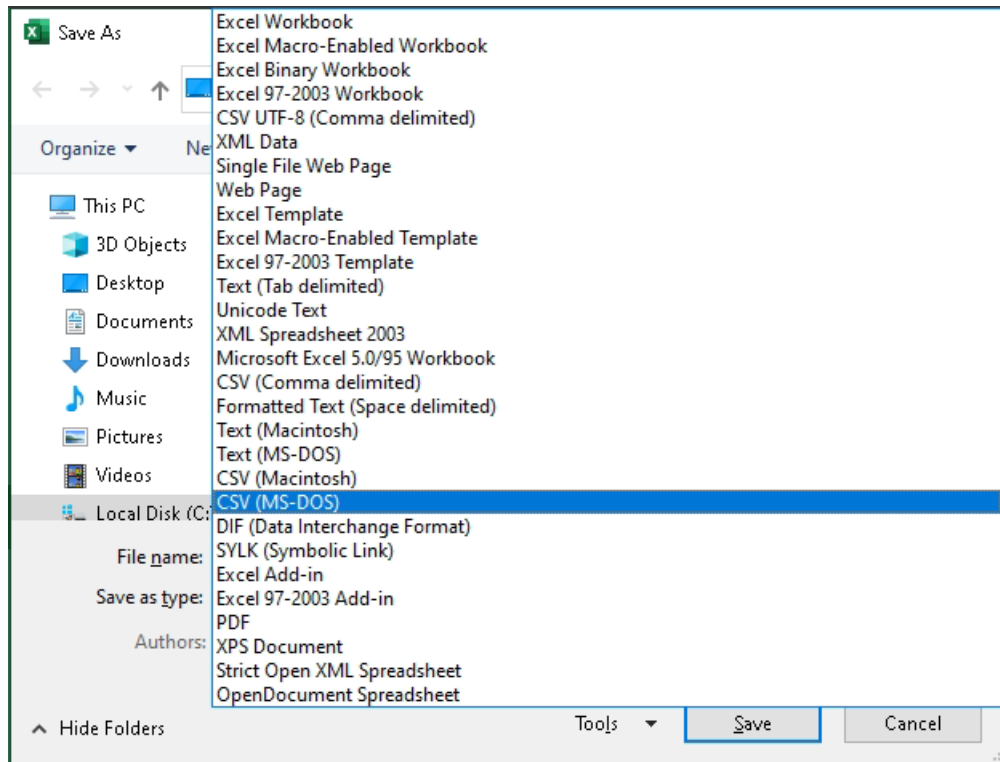

Tank calibration chart file should be named in format NN`CALIB.CSV`, where NN is a tank number, so for tank 1 the file should be named as 01`CALIB.CSV`, for tank 2 – 02`CALIB.CSV` and so on.

After you prepare the tank calibration chart file you need to upload it to the PTS-2 controller and make sure that it is working correctly. For this you need to open the PTS-2 controller web server on Configuration page Tanks tab and there you can select the needed tank, upload the prepared calibration chart and check by entering the height and checking the calculated volume, which should match the chart file:

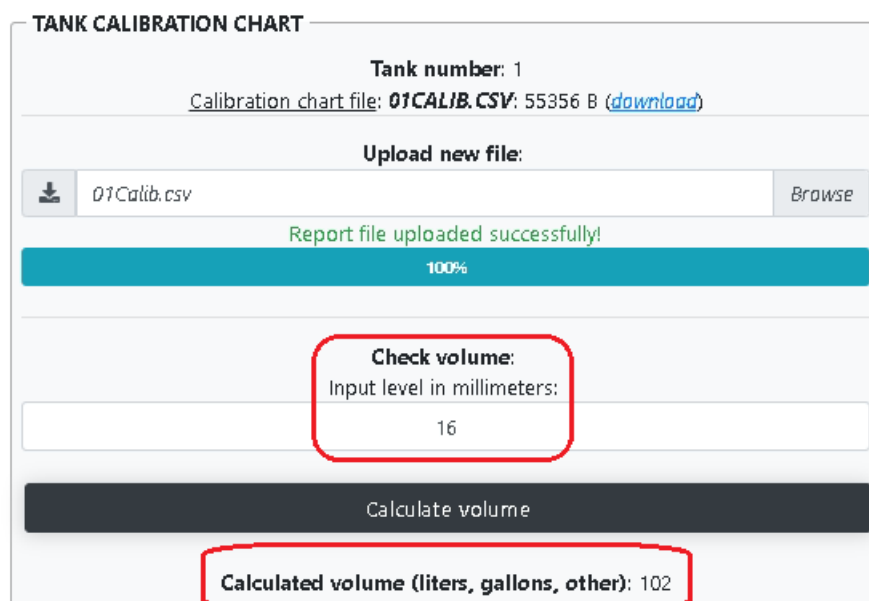

CONFIGURATION FILE PTS_CONFIG_XX.JS

PTS-2 controller has built-in configuration files named `pts_config_xx.js`, where `xx` mean the language, for example:

- `pts_config.en.js` – for English language
- `pts_config.ru.js` – for Russian language
- `pts_config.uk.js` – for Ukrainian language
- `pts_config.es.js` – for Spanish language
- `pts_config.ar.js` – for Arabic language

These files can be requested by addressing to this file (for example for English language https://192.168.1.117/pts_config_en.js in case if usage of HTTPS is selected on DIP-1 switch and IP-address is set to 192.168.1.117).

The configuration file contains:

- list of pumps communication protocols supported
- list of probes communication protocols supported
- list of price boards communication protocols supported
- list of readers communication protocols supported
- list of baud rates supported
- list of parameters supported

Section “*protocols*” contains a list of all supported pumps and probes communication protocols, where each “*protocol*” element contains properties:

- element “*name*” states communication protocol name
- element “*index*” states communication protocol index used for configuration
- element “*type*” states communication protocol type, possible variants are:
 - 0 – pump protocol type
 - 1 – probe protocol
 - 2 – price board protocol
 - 3 – reader protocol

Section “*bauds*” contains a list of all supported baud rates, where each “*baud*” element contains properties:

- element “*baud*” states baud rate value
- element “*index*” states baud rate index used for configuration

Section “*params*” contains a list of all supported parameters. PTS-2 controller uses parameters internally as configurable fields for storing different configuration settings, parameters are united in sets of 4-byte sections, so the maximal value of a parameter section in hexadecimal format can be 0xFFFFFFFF. Thus, each such section can be divided in one or several parameters, for example some of parameters can take only 1 bit, others can be longer up to the size of a whole 4 bytes section. Each “*param*” element describes a separate parameter and contains the following properties:

- element “*short_name*” states parameter short name to be displayed in case of small display
- element “*name*” states parameter name
- element “*description*” states parameter description
- element “*type*” states parameter type, possible variants are:
 - 0 – parameter for PTS-1 controller

- 1 – parameter for PTS-2 controller
 - 2 – parameter for pump specific protocol
 - 3 – parameter for probe specific protocol
 - 4 – parameter common for all pump protocols
 - 5 – parameter common for all probe protocols
- element “*index*” states parameter index used for configuration
- element “*input*” states parameter range of values and meaning and contains the following possible elements:
- element “*type*” states parameter input type, possible values are:
 - 0 – Boolean value taking 1 bit with possible values: 0 for unset, 1 for set

Example:

```
{"name":"Send price command at authorization","description":"Sets whether additional price setting command should be sent at pump authorization.", "protocol":"15", "type":"2", "index":"1", "input":{"type":"0", "mask":"1", "shift":"16", "default":"0"}}
```

This parameter relates to pump protocol 15 (Tatsuno SS-LAN), its index is 1, GUI of software can display this parameter as a checkbox.

Default value is 0 (meaning unchecked state).

Shift of this parameter is 16, so that if the option is checked – then the parameter value is shifted 16 bits from start of the parameter section making the value to be 1000000000000000 in binary format.

- 1 – enumeration with list of values to be stated, in case of this input type the following elements for element “*input*” are possible:
 - element “*enum*” with description of the parameter with property “*value*” stating the parameter value

Example:

```
{"name":"Enter preset order at pump","description":"Sets whether preset of order is done from pump preset keyboard.", "protocol":"16", "type":"2", "index":"1", "input":{"type":"1", "enum":[{"attr":"No", "value":"0"}, {"attr":"Yes", "value":"1"}, {"attr":"In automatic mode", "value":"2"}], "default":"0"}}
```

This parameter relates to pump protocol 16 (Shelf), its index is 1, GUI of software can display this parameter as a dropdown list with possible options:

- No (value 0)
- Yes (value 1)
- In automatic mode (value 2)

Default value is 0 (meaning first option ‘No’).

- 2 – integer value with range of values to be stated, in case of this input type the following elements for element “*input*” are possible:
 - element “*min*” with minimal value of the parameter value
 - element “*max*” with minimal value of the parameter value

Example:

```
{ "name": "Decimal digits quantity", "description": "Sets quantity of
digits after decimal separator used in
pump.", "protocol": "16", "type": "2", "index": "2", "input": { "type": "2", "mi
n": "1", "max": "4", "default": "2" } }
```

This parameter relates to pump protocol 16 (Shelf), its index is 2, GUI of software can display this parameter as updown list with values in range from 1 to 4 and default value 2.

- 3 – float value with range of values to be stated, in case of this input type the following elements for element “input” are possible:
 - element “min” with minimal value of the parameter value
 - element “max” with minimal value of the parameter value
 - element “mul” states the value on which the entered value should be multiplied
 - element “format” states the format of the float number to represent – number of integer and decimal digits

Example:

```
{ "name": "Maximal volume for authorization,
liters", "description": "Sets value of maximal volume for pump
authorization,
liters", "protocol": "16", "type": "2", "index": "3", "input": { "type": "3", "m
in": "1", "max": "9999", "mul": "100", "format": "03.02f", "default": "700.00"
} }
```

This parameter relates to pump protocol 16 (Shelf), its index is 3, GUI of software should display this parameter as float value in format “03.02f” meaning 3 integer digits and 2 decimal digits, default value is 700.00. After entering the value, the system should multiply it on 100 making the decimal digit from it. For example, if the entered value is 123.45 – then the value to be saved should be 12345 = 0x3039.

- element “mask” states how many bits the parameter takes in memory, the values are given in a format of maximal bits value the parameter can take. For example, if the parameter can have a value from 1 to 5 – then its values can take 3 bits maximum, so the maximal bits value is 111 in binary and the mask should equals to 7.
- element “shift” states what is the parameter offset in bits from the 4-bits parameter section value.
- element “default” states what is the parameter default value.

Parameters are saved in memory in hexadecimal format. In case if there are several parameters taking the same parameter section – then all of them should be accounted when writing new parameter value to parameter section.

GPS MODULE

GPS module is a separate small board to be inserted in the socket on the board of PTS-2 controller.



GPS module



GPS antenna

GPS module is used for tracking of fuel tankers location:

- tracking of the present location
- tracking of the whole route covered for specified period
- tracking of the fuel level in tanks while the fuel tanker was moving on route
- tracking of places, where fuel level in tanks was changed (tank should be equipped with the probe)
- tracking of places, in which fuel was dispensed through the flowmeter

Having this information, it is possible to know present location of the fuel tanker on the route and the, most important, to know possible frauds done with fuel while the tanker is on the route because PTS-2 controller records GPS places if any change of fuel level in tank is done, PTS-2 controller automatically sends this data to a remote server for processing and analysis.

Configuration of operation with GPS module is done in parameters of PTS-2 controller on [Configuration](#) page > [Parameters](#) tab:

The screenshot shows the configuration interface for the PTS-2 controller. The top bar displays 'PTS-2 controller' and 'admin Logout'. The main content area is titled '5. DECIMAL DIGITS SYSTEM SETTINGS' and contains several configuration options:

- 5.1. Price display format:** Sets format used on price display (quantity of decimal digits in price). Value: XX.XX (2 decimal digits).
- 5.2. Money amount display format:** Sets format used on money amount display (quantity of decimal digits in money amount). Value: XX.XX (2 decimal digits).
- 5.3. Volume display format:** Sets format used on volume display (quantity of decimal digits in volume). Value: XX.XX (2 decimal digits).
- 5.4. Money amount total counter format:** Sets format of money amount total counter (quantity of decimal digits in money amount total counter value). Value: XX.XX (2 decimal digits).
- 5.5. Volume total counter format:** Sets format of volume total counter (quantity of decimal digits in volume total counter value). Value: XX.XX (2 decimal digits).

Below this is the **6. GPS SETTINGS** section:

- 6.1. GPS module present:** Sets whether GPS module is inserted in controller. Value: 0 (toggle is ON).
- 6.2. Distance between GPS coordinates for saving to SD (km):** Sets minimal distance in kilometers between two GPS coordinates in order to save a new point to SD. Value: 5.
- 6.3. GPS module baud rate:** Sets baud rate used for GPS module. Value: 9600.

GPS module needs time to start operation after power on, which normally takes 2-3 minutes. After signal from satellites is well received – then a LED on the GPS module starts blinking showing that the module switched to operation mode.

Information on data received from the GPS module can be viewed in the PTS-2 controller web-server on [General information](#) page:

GPS RECEIVER DATA

Date/time: 13.12.2021 08:52:52

Latitude: 5030.5179 DD°MM.mmmm' North

Longitude: 03027.1472 DDD°MM.mmmm' East

Speed over ground: 0.31 km/h

Course over ground: 103.03°

Mode: Autonomous

RESET OF CONFIGURATION

Reset of the PTS-2 controller might be needed if you are not able to login the web server due to the user login/password are lost or forgotten. Reset will clear all the configuration to default values.

To reset the PTS-2 controller configuration to the default settings make the following:

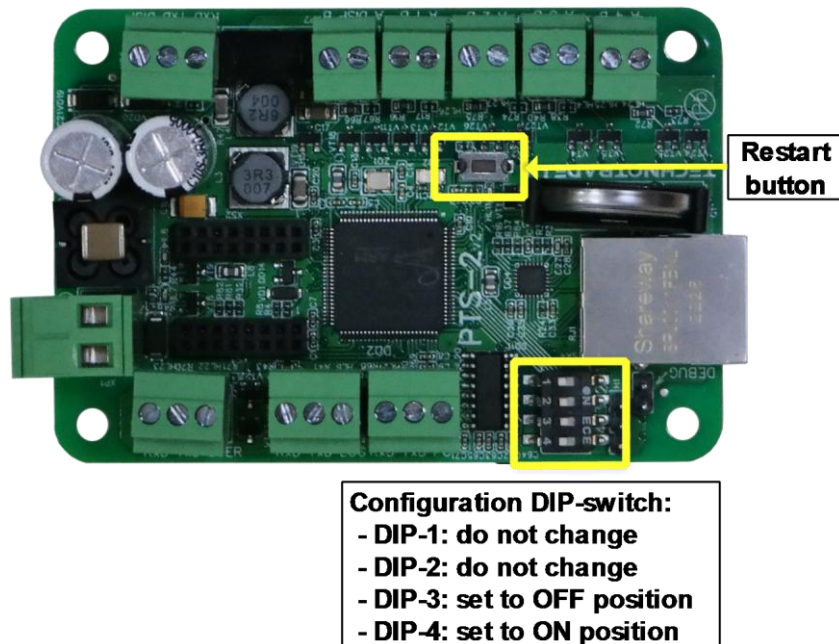

1. Find 4-position DIP-switch on the board of PTS-2 controller and set:
 - DIP-1 switch do not change
 - DIP-2 switch do not change
 - DIP-3 switch set to OFF position
 - DIP-4 switch set to ON position
2. Click *Restart* button on the board of PTS-2 controller
3. After that you should be able to access PTS-2 controller using standard network parameters, described in [Web server](#) section.
4. After that return DIP-4 switch back to OFF position

NOTE! In order to be able to restore configuration of the PTS-2 controller remember to save [backup](#) of the PTS-2 controller configuration. If you have it – then you will be able to restore the configuration after the reset (except users' configuration, which is not saved for backup and not restored to prevent any security loss, so you need to record it manually).

CONNECTION TO DISPENSERS

PTS-2 controller can simultaneously control up to 120 fueling places (120 single-sided dispensers or 25 double-sided dispensers or mixture of single-sided and double-sided dispensers) that use up to 4 various communication protocols (each of the pump ports can be adjusted to a separate communication protocol and baud rate) (some of the pumps might need additional interface converters for connection, please see section [Examples of connection to fuel dispensers](#) for more information).

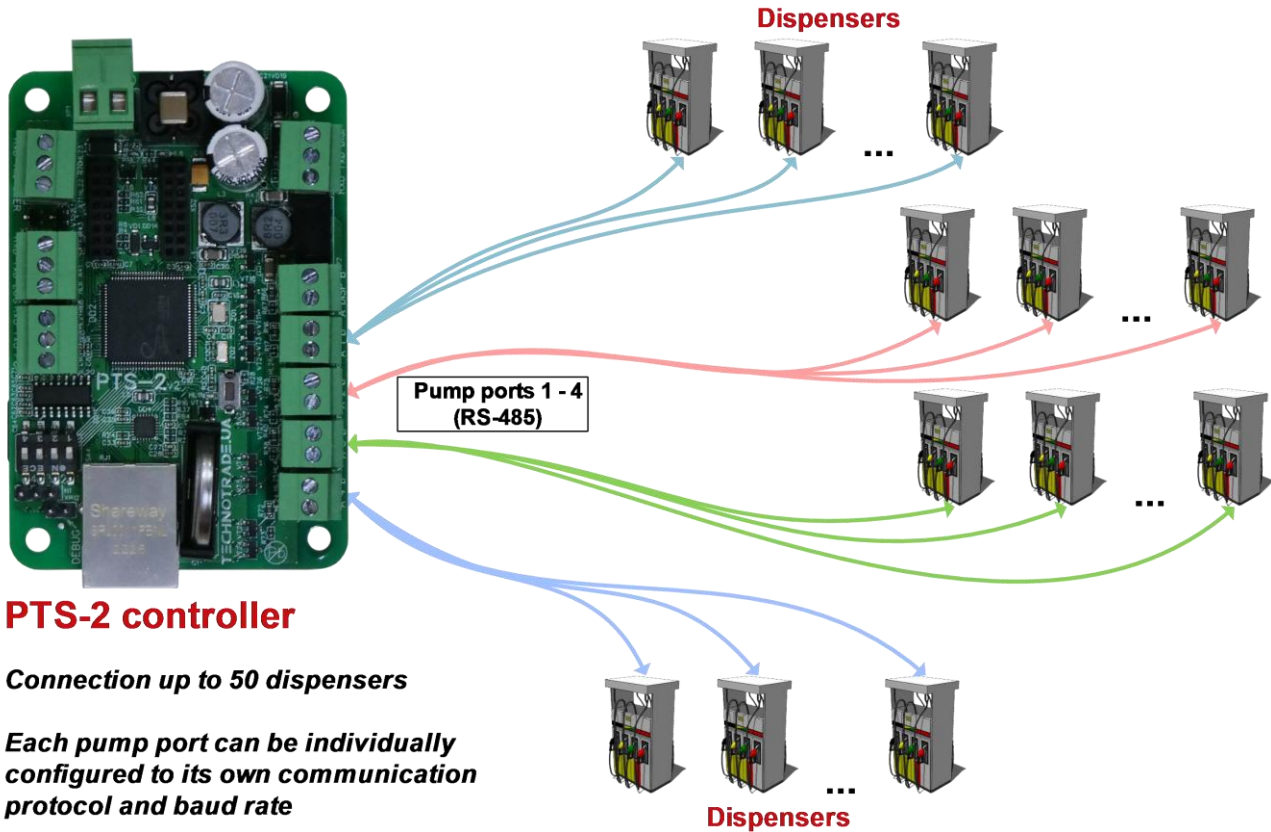

NOTE! If there are less than 4 various types of fuel dispensers at petrol station (which use various communication protocols) then it is recommended to distribute fuel dispensers between 4 pump ports in approximately equal quantities in order to minimize delays between fuel dispensers querying in the same pump port, so that communication with each of the pumps is the most fast and efficient.

NOTE! Technotrade LLC has a support team and provides customers with remote support in configuration and connection to various dispensers' brands for their connection and communication to the PTS-2 controller.

Following actions can be performed with fuel dispensers regardless the brand of the dispenser used:

- get dispenser status
- start/stop fueling process
- suspend/resume fueling process
- set/get nozzles' prices
- get nozzles' total counters
- get filling information during dispensing process (volume, amount, price)
- get transaction information after dispensing process (volume, amount, price)
- calculation of product temperature-compensated volume (in case if there is ATG system or probe installed in tank)
- all pumps' sales data can be recorded in the PTS-2 controller for reporting through a web-browser and additionally uploaded to a remote server for processing and analysis.

Configuration of pumps in the PTS-2 controller is made on [Configuration](#) page > [Pumps](#) tab. This tab allows to configure each pump port (4 pump ports totally) to separate communication protocol and baud rate. Also, you can configure each of the pumps (up to 120) to its own pump port and assign it a physical address (communication address configured inside the dispenser). You can configure many dispensers to the same port, just take into account that communication address of each dispenser on the same pump port should have a unique value.

PTS-2 controller ver. 2023.04.12 13:24:54 admin
Logout

Configuration

Settings **Pumps** Probes Parameters Grades Tanks Nozzles Boards Readers Wireless Users

Get

PUMP PORTS CONFIGURATION

Edit	Port	Protocol	Baud rate
	1	33. DART Simplex	4. 9600
	2	5. Gilbarco Two-Wire	3. 5787
	3	0. -----	0. -----
	4	15. Tatsuno SS-LAN	5. 19200

Set

PUMPS CONFIGURATION

Edit	Pump	Pump port	Physical address
	1	1 port	2 address
	2	1 port	3 address
	3	2 port	7 address
	4	2 port	11 address
	5	4 port	1 address
	6	4 port	2 address
	7	4 port	3 address
	8	0 -----	0 -----
	9	0 -----	0 -----
	10	0 -----	0 -----

Showing 1 to 10 of 50 entries

Previous 1 2 3 4 5 Next

Configuration of pump ports includes setting of communication protocol and baud rate for each of the pump ports and also assigning of pumps to each of the pump ports. Each of the pumps can be assigned to any of the pump ports and requires specification of the pump physical address.

Physical address of the pump means communication address (also named as ID or pump number) of the real fueling place, which is programmed or set in configuration of the fuel dispenser fueling place.

Edit record

Protocol: 15. Tatsuno SS-LAN

Baud rate: 5. 19200

Update

After the pumps configuration is applied you need to recheck that a number of decimal digits configured in the PTS-2 controller matches a number of decimal digits configured in the dispenser displays.

For example, check the values shown on the dispenser displays:

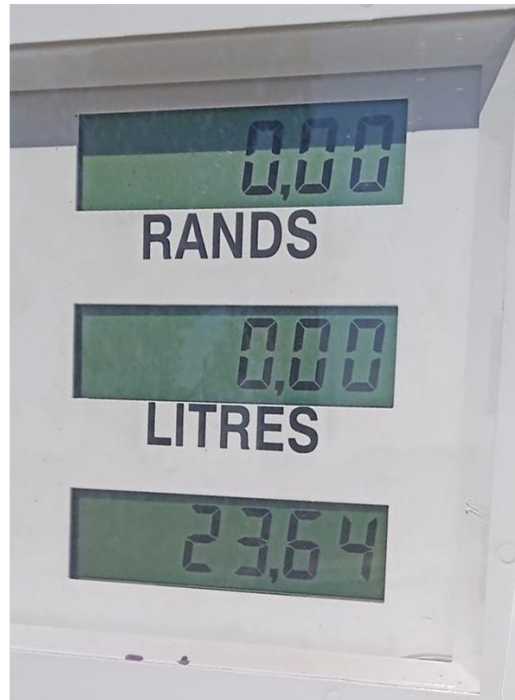

On this example image it shows 2 decimal digits in the values of money amount, volume and price. You need to set in the PTS-2 controller configuration the same number of decimal digits as shown on the dispenser displays. This is done on [Configuration](#) page > [Parameters](#) tab and there select *Device* as *Controller* and scroll to the section named *DECIMAL DIGITS SYSTEM SETTINGS*:

PTS-2 controller
ver. 2023.04.26 16:41:29

admin
Logout

Sets number of stop bits in communication protocol on USER port. 1 bits

4.13. USER port: parity control
 Sets parity control in communication protocol on USER port. None

5. DECIMAL DIGITS SYSTEM SETTINGS

5.1. Price display format
 Sets format used on price display (quantity of decimal digits in price). XX.XX (2 decimal digits)

5.2. Money amount display format
 Sets format used on money amount display (quantity of decimal digits in money amount). XX.XX (2 decimal digits)

5.3. Volume display format
 Sets format used on volume display (quantity of decimal digits in volume). XX.XX (2 decimal digits)

5.4. Money amount total counter format
 Sets format of money amount total counter (quantity of decimal digits in money amount total counter value). XX.XX (2 decimal digits)

5.5. Volume total counter format
 Sets format of volume total counter (quantity of decimal digits in volume total counter value). XX.XX (2 decimal digits)

6. GPS SETTINGS

6.1. GPS module present
 Sets whether GPS module is inserted in controller. 0

6.2. Distance between GPS coordinates for saving to SD (km)
 Sets minimal distance in kilometers between two GPS coordinates in order to save a new point to SD. 5

6.3. GPS module baud rate

After that you need to recheck parameter for each of the pumps on [Configuration](#) page > [Parameters](#) tab and there select *Device* as *Pump*. Parameters are to be checked for each of the pumps individually.

PTS-2 controller foresees specific configuration parameters for each of the pumps. Pump parameters are divided into:

- specific parameters for used pump protocol – such parameters depend on the used communication protocol and are different for different communication protocols
- common parameters, which are same for all pumps regardless of the used communication protocol

The screenshot shows the 'Parameters' configuration page for a pump in the PTS-2 controller interface. The page title is 'PTS-2 controller' with version '2023.04.12 19:28:39' and an 'admin' user logged in. The main navigation bar includes 'Settings', 'Pumps', 'Probes', 'Parameters', 'Grades', 'Tanks', 'Nozzles', 'Boards', 'Readers', 'Wireless', and 'Users'. The 'Parameters' tab is active, showing a 'Get' button, a 'Set' button, and a 'Set default' button. Below these are dropdown menus for 'Device' (set to 'Pump'), 'Number' (set to '1'), and 'Protocol' (set to '33. DART Simplex'). A toggle switch for 'Get parameters values automatically' is turned on. The main content area is a table with columns 'Description', 'Default', and 'Value'. The table is divided into sections: '1. PUMP PROTOCOL SPECIFIC PARAMETERS', '1.1. Nozzles quantity on pump side', '1.2. Use money total counters', '1.3. No FILLING state during dispensing', '1.4. S4 computer is used', '1.5. Enable fast communication', and '1.6. Unite commands at authorization'.

Description	Default	Value
1. PUMP PROTOCOL SPECIFIC PARAMETERS		
1.1. Nozzles quantity on pump side Sets quantity of nozzles used on pump side.	6	3
1.2. Use money total counters Sets whether the money amount total counters should be requested from the dispenser (set in case if they are supported by the dispenser).	No	Using command code 0x65 (bit)
1.3. No FILLING state during dispensing Sets whether a pump does not return FILLING state during dispensing.	0	<input type="checkbox"/>
1.4. S4 computer is used Sets whether a pumphead is using S4 computer.	0	<input type="checkbox"/>
1.5. Enable fast communication Sets whether fast communication with pump should be used. May be not supported by some pumps!	0	<input checked="" type="checkbox"/>
1.6. Unite commands at authorization		

Common parameters divide into following sections:

- *PUMP AUTHORIZATION SETTINGS* – contains various configurations for authorization (for example, to authorize the pump only after nozzle up, automatic authorization and other)
- *TAG VERIFICATION SETTINGS* – contains parameters for operation with tags on the pumps (for example to always verify a tag before sending authorization to the pump)
- *TIMER SETTINGS* – contains timing configurations of the pumps (for example how long to keep the pump authorized without any activity on it)
- *PUMP MULTIPLIERS* – contains settings for adjusting the values of volume, price and amount in case of specific pump display configurations
- *PUMP NOZZLE READERS SETTINGS FOR AUTOMATIC VEHICLES IDENTIFICATION SYSTEM* – contains settings for the AVI system readers installed on the pump nozzles

Normally such configuration is enough for operation with pumps when working with a management system responsible for leading the fuel prices and linking the fuel grades to pump nozzles to pumps. However, if such configuration is needed to be led by the PTS-2 controller – then it is additionally needed to:

1. Configure fuel grades on the [Configuration](#) page > [Grades](#) tab
2. Configure pump nozzles on the [Configuration](#) page > [Nozzles](#) tab

Configuration of fuel grades is made on [Grades](#) tab. This tab allows to configure fuel grades used in the PTS-2 controller. This includes settings of fuel grade name, price per liter/gallon and setting of temperature-expansion coefficient. Also, if there are blended fuel grades – then it is possible to set here the tanks, from which it is mixed (prior to this it is needed to configure tanks on [Tanks](#) tab).

Edit	No.	Name	Price	Temperature expansion coefficient	Blended tank 1	Blend percentage	Blended tank 2
	1	Petrol	1.11	0.0011	0	0	0
	2	Diesel	1.05	0.00082	0	0	0
	3	LPG	0.87	0.00245	0	0	0
	4	Kerosene	1.01	0.00087	0	0	0
	5		0	0.00000	0	0	0
	6		0	0.00000	0	0	0
	7		0	0.00000	0	0	0
	8		0	0.00000	0	0	0
	9		0	0.00000	0	0	0
	10		0	0.00000	0	0	0

[Nozzles](#) tab allows to configure linkage of pump nozzles to fuel grades and to tanks (optional).

Edit	Pump	Grade noz. 1	Tank noz. 1	Grade noz. 2	Tank noz. 2	Grade noz. 3	Tank noz. 3	Grade noz. 4	Tank noz. 4	Grade noz. 5	Tank noz. 5	Grade noz. 6	Tank noz. 6
	1	Grade 1 (Petrol, price: 1.11)	Tank 1 (Petrol)	Grade 2 (Diesel, price: 1.05)	Tank 2 (Diesel)	0	0	0	0	0	0	0	0
	2	Grade 2 (Diesel, price: 1.05)	Tank 2 (Diesel)	Grade 1 (Petrol, price: 1.11)	Tank 1 (Petrol)	0	0	0	0	0	0	0	0
	3	Grade 1 (Petrol, price: 1.11)	Tank 1 (Petrol)	Grade 2 (Diesel, price: 1.05)	Tank 2 (Diesel)	Grade 4 (Kerosene, price: 1.01)	Tank 4 (Kerosene)	0	0	0	0	0	0
	4	Grade 4 (Kerosene, price: 1.01)	Tank 4 (Kerosene)	Grade 2 (Diesel, price: 1.05)	Tank 2 (Diesel)	Grade 1 (Petrol, price: 1.11)	Tank 1 (Petrol)	0	0	0	0	0	0
		Grade 3 (LPG,	Tank 3										

After that control over the dispensers can be made from the [Pumps control](#) page, which allows to monitor all pumps and provide control over them.

The screenshot shows the 'Pumps control' interface with seven individual pump status cards. Each card displays the pump number, status (NOZZLE, FILLING, or IDLE), amount, volume, price, nozzle type, and Start/Stop buttons.

Pump	Status	Amount	Volume	Price	Nozzle
1	NOZZLE	12.18	8.40	1.11	Petrol (1.11)
2	FILLING	19.53	18.60	1.05	Diesel (1.05)
3	IDLE	0.00	0.00	1.11	Petrol (1.11)
4	NOZZLE	0.00	0.00	0.00	Petrol (1.11)
5	FILLING	17.98	16.20	1.11	Petrol (1.11)
6	IDLE	0.00	0.00	1.11	Petrol (1.11)
7	IDLE	0.00	0.00	1.11	Petrol (1.11)

The screenshot shows the 'Pumps control' interface with a summary table and control buttons. The table lists pump details, and the control area includes buttons for Authorize, Stop, Resume, Suspend, and EMERGENCY STOP, along with utility buttons like Get prices and Set prices.

Pump	Status	Nozzle	Price	Filled volume	Filled amount	Total volume	Total amount	User	Request
1	NOZZLE	1 (Petrol)	1.11	8.40	12.18	0.00	0.00		
2	FILLING	2 (Diesel)	1.05	57.20	60.06	0.00	0.00	admin	
3	IDLE	0	1.11	0.00	0.00	0.00	0.00		
4	NOZZLE	4	0.00	0.00	0.00	0.00	0.00		
5	FILLING	1 (Petrol)	1.11	54.80	60.83	0.00	0.00	admin	
6	IDLE	0	1.11	0.00	0.00	0.00	0.00		
7	IDLE	0	1.11	0.00	0.00	0.00	0.00		

Control area settings:
 Pump: 1 | Preset type: Volume | Preset dose: 1.00

Control buttons:
 Nozzle 1: Petrol 1.11 (Selected)
 Nozzle 2: Diesel 1.05
 Nozzle 3: LPG 1.45
 Nozzle 4: 0.00
 Nozzle 5: 0.00
 Nozzle 6: 0.00

Utility buttons:
 Authorize, Stop, Resume, Suspend, EMERGENCY STOP, Get prices, Set prices, Get total counters, Get tag ID, Turn lights on, Turn lights off

CONNECTION TO ATG SYSTEMS AND PROBES

PTS-2 controller can simultaneously control up to 20 automatic tank gauges (probes) (separate probes or probes connected to ATG systems / consoles) that use up to 3 various communication protocols (each of the probe ports can be adjusted to a separate communication protocol, baud rate and communication settings: number of data bits and stop bits, parity) (see section [Examples of connection to ATG systems](#)).

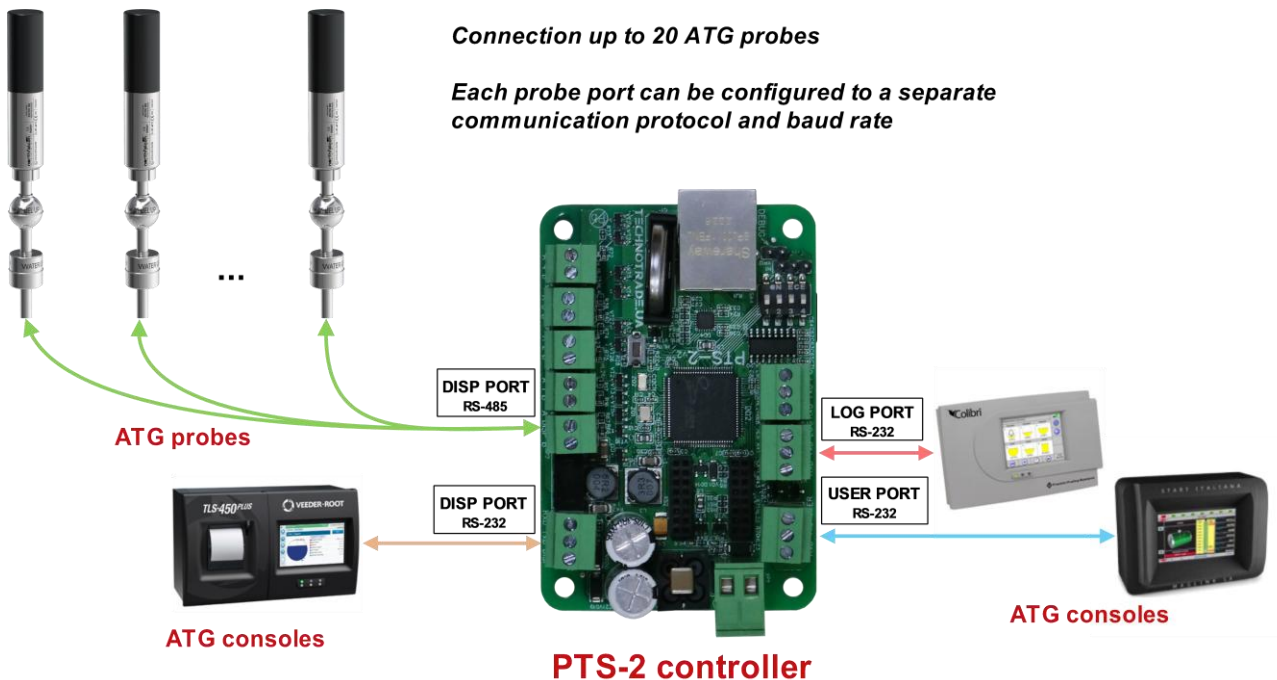

NOTE! DISP port provides a possibility to connect ATG system (probes) over either RS-485 or RS-232 interfaces – interface is selected using a configuration parameter in PTS-2 controller.

NOTE! Technotrade LLC has a support team and provides customers with remote support in configuration and connection of various ATG consoles' and probes' brands for their connection and communication to the PTS-2 controller.

Following features are present for any tank regardless of the ATG system or probe used:

- informing probes' measurements data: product level, water level, temperature, product volume, water volume, product temperature-compensated volume, tank ullage, product density, product mass
- In case if the probes do not provide volume measurements – then PTS-2 controller can provide calculation of product volume based on tank calibration chart and product level, measured by probe
- automatic calculation of product temperature-compensated volume in tank
- automatic detection of product in-tank deliveries received, it can be done even during pumps fueling process
- automatic calculation of product mass
- automatic tank leakage detection
- automatic track of tank alarms: probe failures, high and low product levels, high water level
- at communication to ATG consoles PTS-2 controller can be used for sending fuel dispensers sales data to consoles in order to make console provide tanks reconciliation reports and automatic tanks calibration
- all tanks' measurements data can be recorded in PTS-2 controller for reporting through a web-browser and additionally uploaded to a remote server for processing and analysis

Configuration of probes is made on [Configuration](#) page > [Probes](#) tab. This tab allows to configure each probe port (up to 3 probe ports) to separate communication protocol and baud rate. Also, you can configure each of the probes (up to 20) to its own probe port and assign it a physical address (communication address set in probe or in ATG console). You can configure many probes to the same port.

The screenshot displays the 'Probes' configuration page in the PTS-2 controller interface. The page is split into two main sections: 'Get' and 'Set'.

PROBE PORTS CONFIGURATION (Get):

Edit	Port	Protocol	Baud rate
	DISP	24. Fafnir Torrix RS-485	4. 9600
	LOG	0. -----	0. -----
	USER	1. Gilbarco Veeder Root	4. 9600

PROBES CONFIGURATION (Set):

Edit	Probe	Probe port	Physical address
	1	USER	1
	2	USER	2
	3	DISP	1
	4	DISP	2
	5	DISP	3
	6	0 -----	0
	7	0 -----	0
	8	0 -----	0
	9	0 -----	0
	10	0 -----	0

Showing 1 to 10 of 50 entries

Navigation: Previous **1** 2 3 4 5 Next

Configuration of probe ports includes setting of communication protocol and baud rate for each of the probe ports and also assigning of probes to each of the probe ports. Each of the probes can be assigned to any of the probe ports and requires specification of the probe physical address.

Physical address of the probe means address of the ATG system probe, which is programmed or set in configuration of the ATG system console or in probe (in some models of probes address mean serial number stated on the probe label).

Edit record ✕

Protocol: 1. Gilbarco Veeder Root

Baud rate: 4. 9600

Configuration of the tanks is made on [Configuration](#) page > [Tanks](#) tab. This tab allows to configure tanks: to set tank’s fuel grade, height, alarms. Also, you can assign a calibration chart for each of the tanks and check it.

Get		Set							
Edit	Tank	Fuel grade	Height, mm	Critical high product alarm, mm	High product alarm, mm	Low product alarm, mm	Critical low product alarm, mm	High water alarm, mm	Stop pumps at reaching the critical low product height
	1	Grade 1 (Petrol, price: 1.11)	3750	3700	3650	150	100	50	Yes
	2	Grade 2 (Diesel, price: 1.05)	3250	3200	3150	150	100	50	Yes
	3	Grade 3 (LPG, price: 0.87)	1750	1700	1650	100	50	0	No
	4	Grade 4 (Kerosene, price: 1.01)	2750	2700	2650	150	100	50	Yes
	5	0	0	0	0	0	0	0	No
	6	0	0	0	0	0	0	0	No
	7	0	0	0	0	0	0	0	No

Edit record

Fuel grade: Grade 1 (Petrol, price: 1.11) ▾

Height, mm:

Critical high product alarm, mm:

High product alarm, mm:

Low product alarm, mm:

Critical low product alarm, mm:

High water alarm, mm:

Stop pumps at reaching the critical low product height: Yes No

NOTE! It is assumed that tanks’ IDs completely correspond to probes’ IDs in meaning: tank 1 corresponds to probe 1, tank 2 – to probe 2, tank N – to probe N.

It is possible to apply alarms for high and low product and water levels and also to set to stop pumps automatically when the product level lowers below the critical low value.

For assigning a tank calibration chart it is necessary to select a raw in a table for specific tank and in field under a tanks table to select a path to the tank calibration chart file.

The screenshot shows the PTS-2 controller interface. At the top, there is a header with 'PTS-2 controller', version '2021.12.13 10:38:43', and user 'admin Logout'. Below the header is a table with 10 rows and 10 columns. The first row is selected. Below the table, there is a pagination control showing 'Showing 1 to 10 of 50 entries' and '1 row selected'. A modal window titled 'TANK CALIBRATION CHART' is open, showing 'Tank number: 1' and 'Calibration chart file: 01CALIB.CSV: 5712 B (download)'. The modal has an 'Upload new file:' section with a 'Browse' button. Below that is a 'Check volume:' section with 'Input level in millimeters:' and a text input field containing '100'. A 'Calculate volume' button is present, and below it, the 'Calculated volume (liters, gallons, other): 441' is displayed.

Tank ID	Grade 4 (LPG, price: 0.87)	1750	1700	1650	100	50	0	Yes
4	Grade 4 (LPG, price: 0.87)	1750	1700	1650	100	50	0	Yes
5	0	0	0	0	0	0	0	No
6	0	0	0	0	0	0	0	No
7	0	0	0	0	0	0	0	No
8	0	0	0	0	0	0	0	No
9	0	0	0	0	0	0	0	No
10	0	0	0	0	0	0	0	No

Button *Calculate volume* allows to check tank's calibration chart by checking volume for any level entered.

The screenshot shows the 'TANK CALIBRATION CHART' modal window. It displays 'Tank number: 1' and 'Calibration chart file: 01CALIB.CSV: 5712 B (download)'. The 'Upload new file:' section shows a file named '01Calib.csv' uploaded successfully, with a progress bar at 100%. Below that is the 'Check volume:' section with 'Input level in millimeters:' and a text input field containing '131'. A 'Calculate volume' button is present, and below it, the 'Calculated volume (liters, gallons, other): 700' is displayed.

NOTE! It is possible to set a calibration chart for the tank after configuration of tanks is saved.

NOTE! Structure of tank calibration chart files is described in section [Files stored on SD flash disk](#).

After that you need to recheck parameter for each of the pumps on [Configuration](#) page > [Parameters](#) tab and there select *Device* as *Probe*. Parameters are to be checked for each of the probes individually.

PTS-2 controller foresees specific configuration parameters for each of the probes. Probe parameters are divided into:

- specific parameters for used probe protocol – such parameters depend on the used communication protocol and are different for different communication protocols
- common parameters, which are same for all probes regardless of the used communication protocol

The screenshot shows the 'Parameters' configuration page for a probe in the PTS-2 controller. The page has a dark sidebar on the left with navigation icons. The main content area has a top navigation bar with tabs for Settings, Pumps, Probes, Parameters (selected), Grades, Tanks, Nozzles, Boards, Readers, Wireless, and Users. Below the tabs are three buttons: 'Get', 'Set', and 'Set default'. The 'Get' button is active, and the 'Device' dropdown is set to 'Probe'. The 'Number' dropdown is set to '1', and the 'Protocol' dropdown is set to '1. Gilbarco Veeder Root'. There is a toggle switch for 'Get parameters values automatically' which is turned on. Below this is a table with columns 'Description', 'Default', and 'Value'.

Description	Default	Value
1. PROBE GENERAL SETTINGS		
1.1. Probe offset from tank bottom, mm Sets offset between probe bottom edge and tank's bottom in millimeters, this setting is used for automatic calculation of product and water volume based on tanks' calibration charts.	0	<input type="text" value="5"/>
1.2. Negative probe offset from tank bottom, mm Sets negative value for offset between probe bottom edge and tank's bottom.	0	<input type="checkbox"/>
1.3. Probe water float minimal level, mm Sets minimal water level, which can be detected by the probe in millimeters. For lesser water level the controller will provide 0 for water level. This parameter is needed for some magnetostrictive probes, in which due to the construction of the water float in the bottom of the probe informs some water level value even if there is no water present.	0	<input type="text" value="5"/>
1.4. Automatic calculation of product volume Sets to enable automatic calculation of product volume in tanks based on tanks' calibration charts. This option needs tanks to have calibration charts configured in controller.	0	<input checked="" type="checkbox"/>

In common parameters it is possible to configure different settings, for example:

- probe offset from a tank's bottom
- automatic calculation of product volume based on tank's calibration chart
- automatic calculation of product temperature compensated volume
- automatic registration of in-tank deliveries
- automatic check of tank leakages
- automatic calculation of product mass
- automatic check of alarms
- others

Connected ATG systems and probes might have specific configuration for communication settings (number of data bits and stop bits, parity). Such parameters for each of the probe ports are configured on [Configuration](#) page > [Parameters](#) tab and there select *Device* as *Controller* and scroll to the section named *PORTS FLEXIBLE COMMUNICATION SETTINGS*:

The screenshot shows the '4. PORTS FLEXIBLE COMMUNICATION SETTINGS' section of the PTS-2 controller interface. It contains 12 numbered settings for DISP and LOG ports, including interface type, flexible communication settings, data bits, stop bits, and parity control.

Setting ID	Description	Value	Control
4.1	DISP port interface	RS-485 interface	Dropdown menu (RS-485 interface)
4.2	DISP port: use flexible communication settings	0	Toggle switch (ON)
4.3	DISP port: number of data bits	8 bits	Dropdown menu (8 bits)
4.4	DISP port: number of stop bits	1 bits	Dropdown menu (1 bits)
4.5	DISP port: parity control	None	Dropdown menu (None)
4.6	LOG port: use flexible communication settings	0	Toggle switch (OFF)
4.7	LOG port: number of data bits	8 bits	Dropdown menu (8 bits)
4.8	LOG port: number of stop bits	1 bits	Dropdown menu (1 bits)
4.9	LOG port: parity control	None	Dropdown menu (None)
4.10	USER port: use flexible communication settings	0	Toggle switch (ON)
4.11	USER port: number of data bits	8 bits	Dropdown menu (8 bits)
4.12	USER port: number of stop bits	1 bits	Dropdown menu (1 bits)

After that monitoring over tanks and their measurements parameters including alerts and last in-tank deliveries can be made from the [Tanks monitoring](#) page.

The screenshot shows the 'Tanks monitoring' page with three tank status cards: Petrol (95%), Diesel (57%), and LPG (1%). Each card displays various measurement parameters.

Tank	Level (%)	Product height	Product volume	Product TC volume	Product ullage	Water height	Water volume	Temperature	Product density	Product mass
1 Petrol	95%	940 mm	20000 L	19900 L	1000 L	20 mm	200 L	24.7 °C	759 kg/m ³	1500 kg
2 Diesel	57%	1000 mm	20000 L	19900 L	15000 L	10 mm	100 L	20 °C	759 kg/m ³	15200 kg
3 LPG	1%	50 mm	300 L	300 L	25400 L	0 mm	0 L	19.7 °C	559 kg/m ³	100 kg

TANKS AUTOMATIC CALIBRATION

At petrol stations horizontal cylindrical steel tanks are used to store petroleum products. The tank is a measuring instrument that has a calibration table compiled during its manufacture process. The calibration chart is a document, which stores correspondence between the fuel height in tank and its volume. The tank calibration chart is used for calculation of the fuel volume remains in tanks, in-tank deliveries registration, temperature-compensated volume calculation, others.

During operation tanks tend to change their parameters due to various types of deformations and external influences: this may be deformation of the body of the tank, tank tilt, foreign objects entering the tank, etc. Therefore, during operation of the tank the initial calibration chart of the tank becomes more and more different from its real calibration chart. The discrepancy between the actual calibration chart and the initial chart, which was provided from the factory at tank supply, leads to the loss of real accounting of the movement of petroleum products at petrol stations. It leads to a necessity to provide periodically tank recalibration in order to prepare a new actual calibration chart, which corresponds to present tank state.

Classical method of tank recalibration includes emptying of the tank from fuel and then a special procedure of filling/unfilling the fuel with water. This procedure is quite costly because it requires a special equipment and also you need to stop the operations with the tank, which leads to stopping of the petrol station operation, disposal of used dirty water and other issues.

The PTS-2 forecourt controller is able to perform tanks automatic calibration automatically without stopping the petrol station operation and any intervention in it. The process is fully automated and each tank's calibration chart is automatically calculated and adjusted in the process of the tank operations. For this process the PTS-2 controller communicates to both the pumps and the ATG probes installed inside the tanks. In the result of this process the PTS-2 controller forms and constantly adjusts the accurate calibration charts for each of the tanks, which suit to their actual state and which are used for precise calculation of the fuel volume remains in tanks, in-tank deliveries registration, temperature-compensated volume calculation and other technological processes.

The PTS-2 forecourt controller is able to constantly monitor sales through pumps and measure fuel level in tanks, which are linked to pump nozzles. Having this information the PTS-2 controller can realtime create a chart of interval volumes – volumes, which the tank stores on each interval of height (with 10 mm step). Having accumulated data on interval volumes the PTS-2 controller can generate a calibration chart for the tank.

To enable tanks automatic calibration it is necessary to make the following few steps in the PTS-2 controller configuration:

1. All tanks must have level probes configured on [Configuration](#) page > [Probes](#) tab in the PTS-2 controller web interface. These probes must be able to measure fuel level and temperature.
2. Having received measurement data from the level probe you need to compare it to level in tank measured physically using a meter stick to compare these values and understand the difference between them – this value is named as offset of the probe from the tank bottom.
3. The tanks must be configured on [Configuration](#) page > [Tanks](#) tab.
4. Fuel grades, which are present inside the tanks, must be configured on [Configuration](#) page > [Grades](#) tab.
5. All pump nozzles, which are linked to these tanks, must have this linkage configured on [Configuration](#) page > [Nozzles](#) tab. Linkage of pump nozzles must be done to fuel grades and tanks.

After all the abovementioned settings are configured in the PTS-2 controller then on [Configuration](#) page > [Tanks](#) tab you can select the following things in configuration for each of the tanks:

Edit record for tank 1

Fuel grade:	<input type="text" value="Grade 1 (Petrol, price: 31)"/>
Tank shape:	<input type="text" value="Horizontal cylinder with spherical bot"/>
Tank diameter, mm:	<input type="text" value="3130"/>
Tank full length, mm:	<input type="text" value="8500"/>
Tank cylinder length, mm:	<input type="text" value="8000"/>
Tank approximate volume, L:	<input type="text" value="64120"/>
Probe offset from tank bottom, mm:	<input type="text" value="0"/>
Automatically calculate volume using tank calibration chart:	<input type="text" value="On basis of automatic calibration cha"/>
Enable automatic calibration:	<input checked="" type="checkbox"/>
Critical high product alarm, mm:	<input type="text" value="3000"/>
High product alarm, mm:	<input type="text" value="2900"/>
Low product alarm, mm:	<input type="text" value="50"/>

1. You need to select the tank shape. Presently it is possible to select the tank shape from the following shape types:
 - horizontal cylindrical tank with flat bottoms
 - horizontal cylindrical tank with spherical (elliptical) bottoms
 - horizontal cylindrical tank with conical bottoms
 - vertical cylindrical tank
 - rectangular tan
2. For the selected tank shape you need to set the dimensions. For example, in case if your tank is horizontal cylindrical tank with spherical (elliptical) bottoms – then you need to enter the following dimensions for your tanks:

- tank diameter, mm
 - tank full length, mm
 - tank cylinder length, mm
3. There is a volume field, which shows the approximate full volume of tank for selected tank shape and dimensions. It can be helpful for selection of the correct tank dimensions.
 4. In case if there is an difference in the values of level measurement received from the tank level probe and the value of level measured physically using a meter stick – then you need to enter this difference as probe offset from the tank bottom.
 5. As the last step click to enable tank automatic calibration.

After the configuration is applied a calculated tank calibration chart will be shown for the selected tank number:

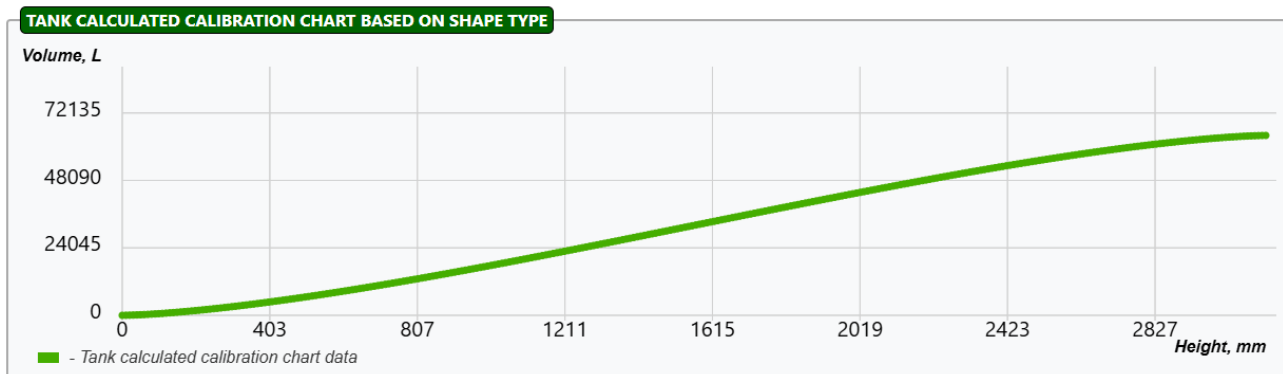

Having the automatic calibration parameter configured for the tank, the PTS-2 controller will be all the time tracking each performed pump transaction and levels of fuel inside the tank and generating/adjusting the tank calibration data. Duration of this process can take some days depending on the fuel movements inside the tanks. Normally no special change of tank behaviour is needed, but in order to make this process be finished faster you can make the following: try to perform in-tank deliveries of fuel inside the tank until tank's maximum level and after that keep fillings of fuel through pumps from the tank without any additional in-tank deliveries until the lowest possible level in tank. The more such attempts are made – the more accurate the generated tank calibration data will be.

On the interval volumes chart all tracked intervals will be shown:

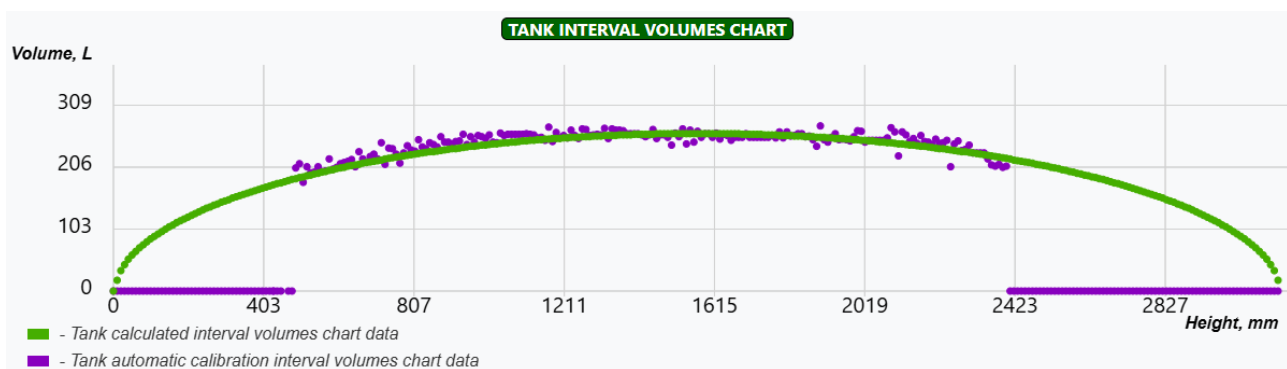

On this chart the tracked intervals are shown in purple color and the calculated interface volumes based on tank shape are shown in green color. This chart shows volume of each of the measured intervals. It is important to mention that the measured volumes must be located along the curve of the the calculated interval volumes (based on the tank shape). For untracked intervals the volume equals 0 (normally in

bottom and top of the tank) – for these intervals the calculated interval volumes based on tank shape are used.

In case if the measured volumes of intervals are not located along the curve of the the calculated interval volumes – then it can mean about a serious damage of the tank shape or a problem of the ATG measurement probe, for example (marked with red color):

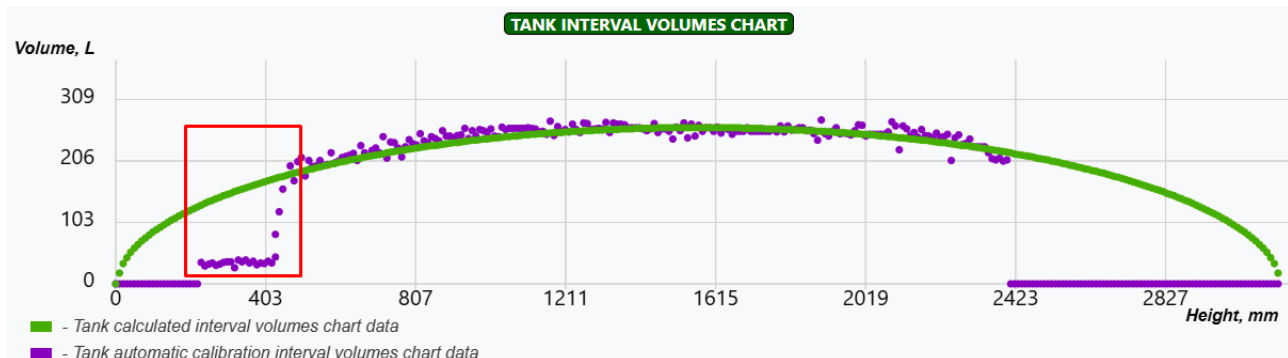

Having accumulated enough data it is possible to generate a tank automatic calibration chart:

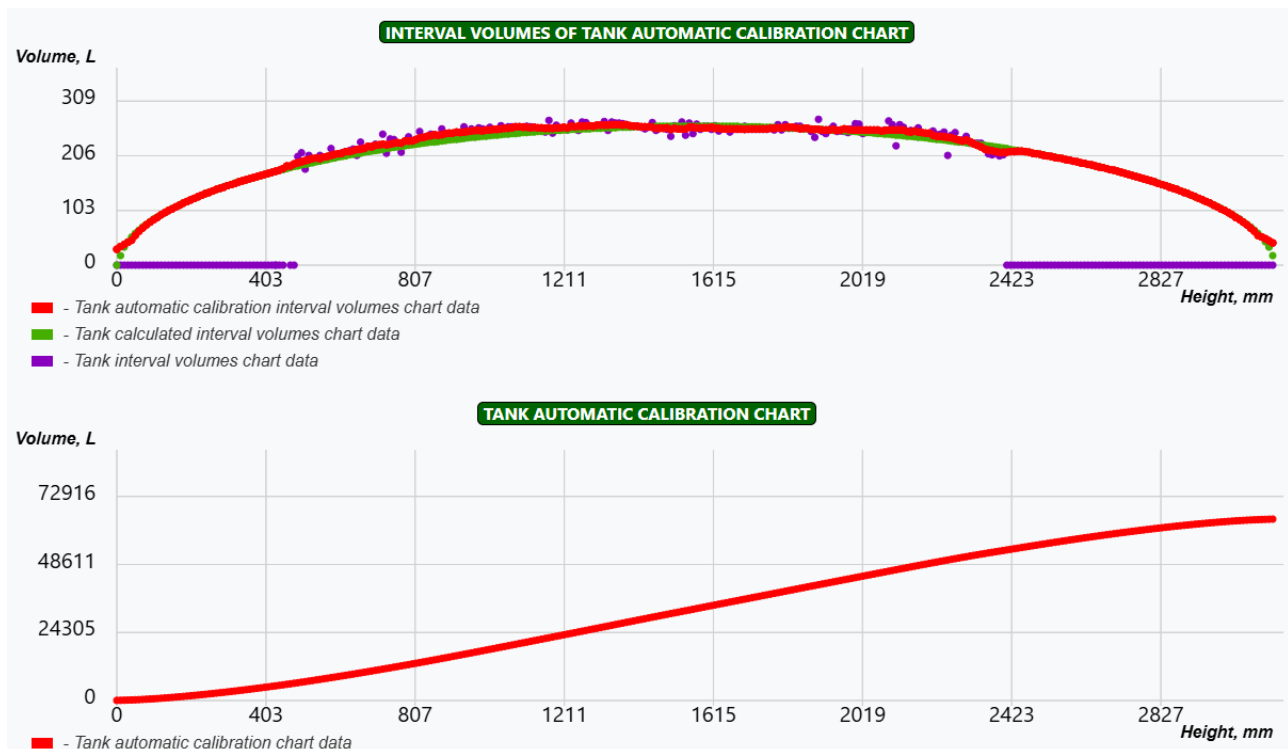

The PTS-2 controller applies all the measured tank interval volumes, performs smoothing and provides ready calibration chart data.

In parameters list of the PTS-2 controller on [Configuration](#) page > [Parameters](#) tab it is possible to configure width of the window for smoothing the interval volumes chart for generation of the automatic tank calibration chart.

The generated calibration table can be automatically compared to a factory initial calibration chart of the tank (if such tank factory caliibration chart is entered in the PTS-2 controller configuration):

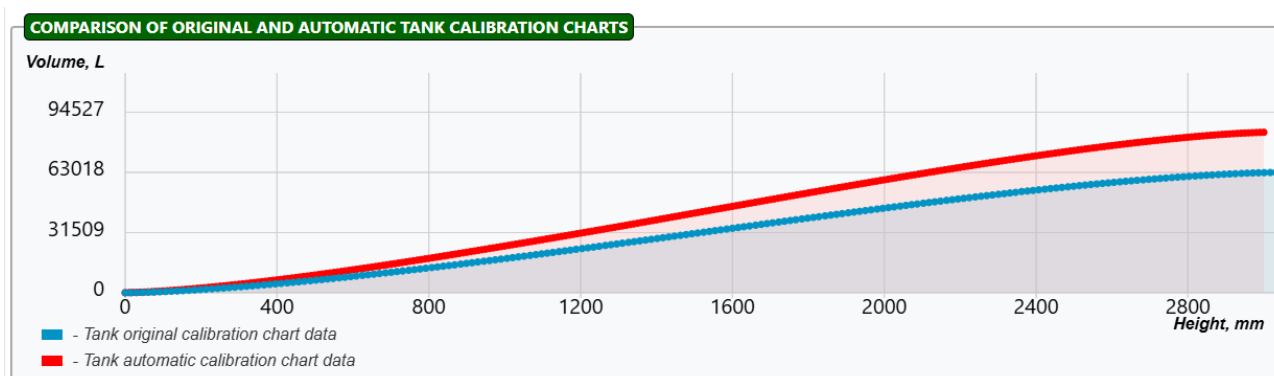

Tank automatic calibration is being performed continuously all the time. On [Configuration](#) page > [Settings](#) tab in field “DAILY PROCESSING TIME” it is possible to set a time for daily performing recalculation of the tank automatic calibration chart to always have the latest data used for tank calibration.

DAILY PROCESSING TIME

Daily processing time

The process runs automatically every day at the specified time.

Make automatic processing of files stored on SD flash disk of the controller.

This process may take several minutes, during this time the controller does not to respond external influences.

Make automatic backup of controller configuration

Sets automatic daily backup of controller configuration.

Make regeneration of tanks automatic calibration charts

Sets automatic daily regeneration of tanks automatic calibration charts if this option is configured for tanks.

Get

Set

Perform now

CONNECTION TO PRICE BOARDS

PTS-2 controller allows to control same time up to 5 price boards each having up to 10 price displays, at this connection of 3 different brands of price-boards using different communication protocols is possible same time (each of the ports can be adjusted to a separate communication protocol, baud rate and communication settings: number of data bits and stop bits, parity).

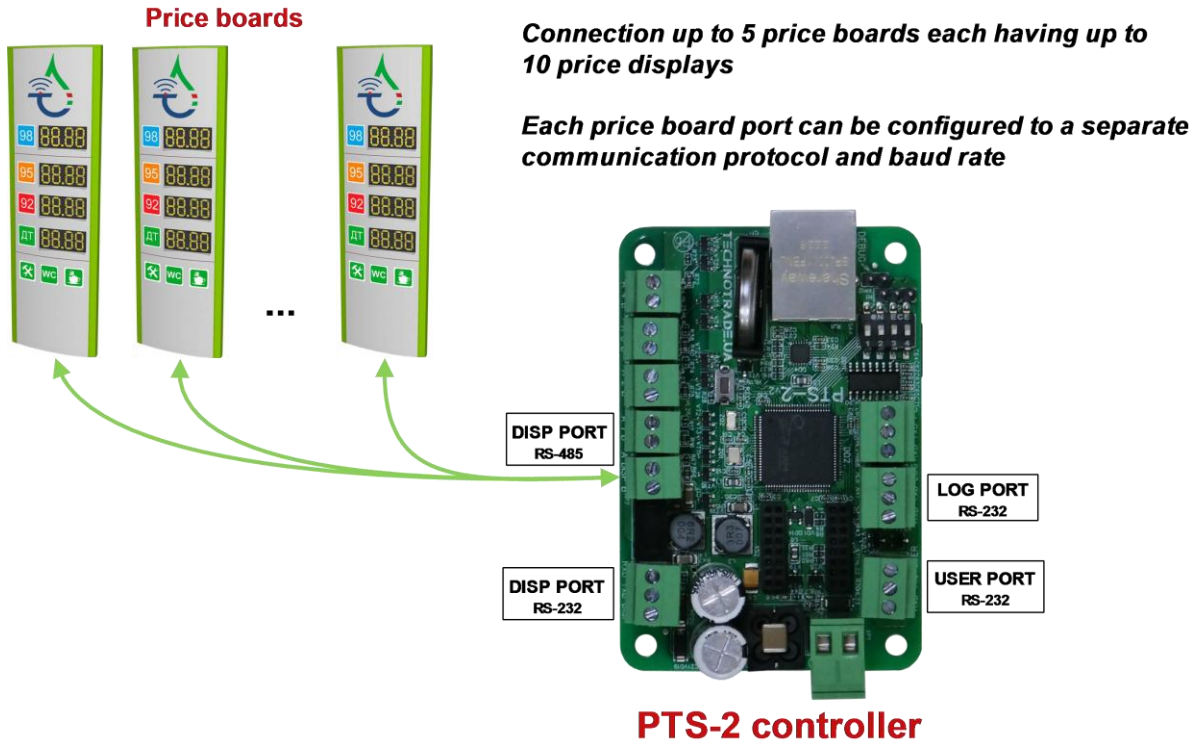

NOTE! DISP port provides a possibility to connect price boards over either RS-485 or RS-232 interfaces – interface is selected using a configuration parameter in PTS-2 controller.

NOTE! Technotrade LLC has a support team and provides customers with remote support in configuration and connection of various price boards' and price poles' brands for their connection and communication to the PTS-2 controller.

Before connecting the price board you need to configure the fuel grades and their prices in the PTS-2 controller. Configuration of fuel grades is made on [Configuration](#) page > [Grades](#) tab. This tab allows to configure fuel grades used in the PTS-2 controller. This includes settings of fuel grade name, price per liter/gallon and setting of temperature-expansion coefficient. Also, if there are blended fuel grades – then it is possible to set here the tanks, from which it is mixed (prior to this it is needed to configure tanks on [Tanks](#) tab).

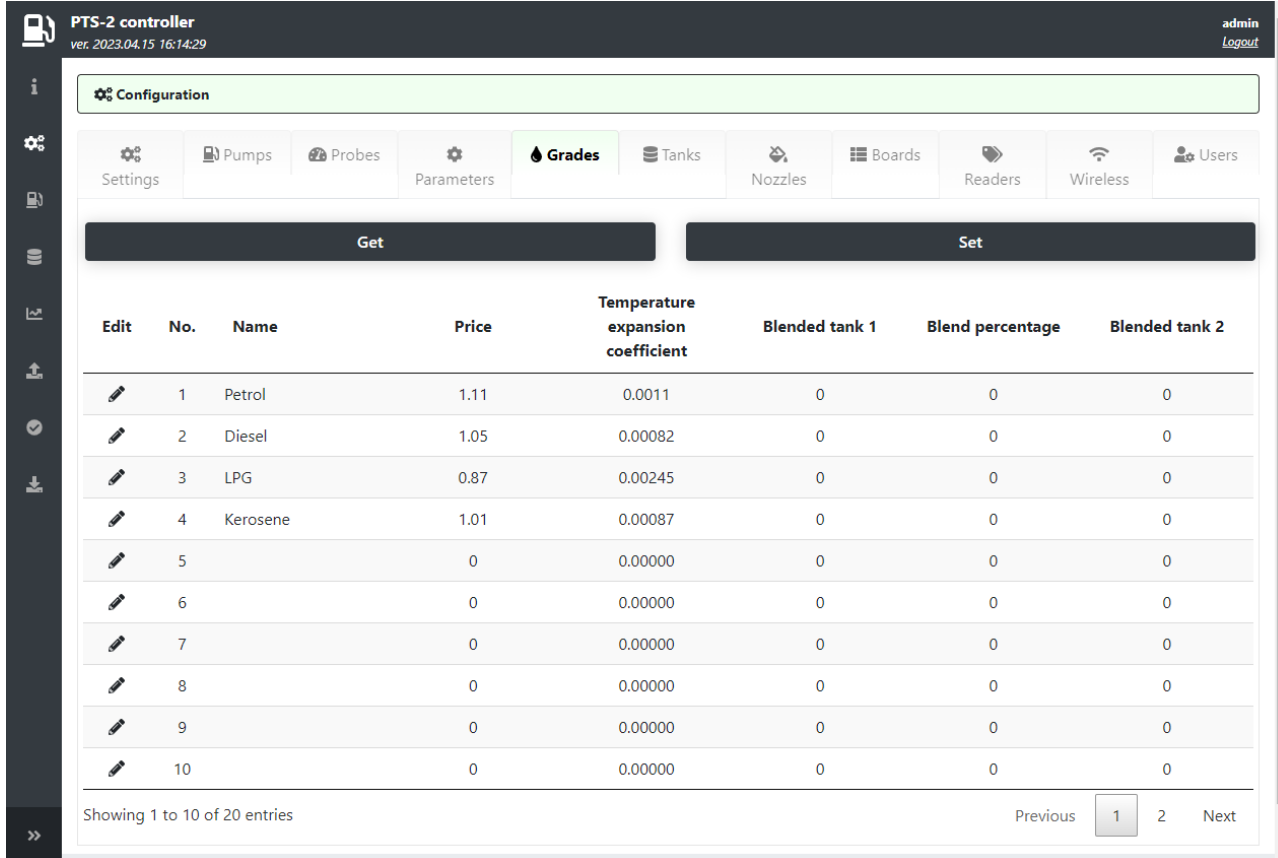

Configuration of price boards is made on [Configuration](#) page > [Boards](#) tab. This tab allows to configure ports for communication with price boards, you can configure each of the price boards (up to 5) to its own port and assign it a physical address (communication address configured inside the price board). You can configure many price boards to the same port.

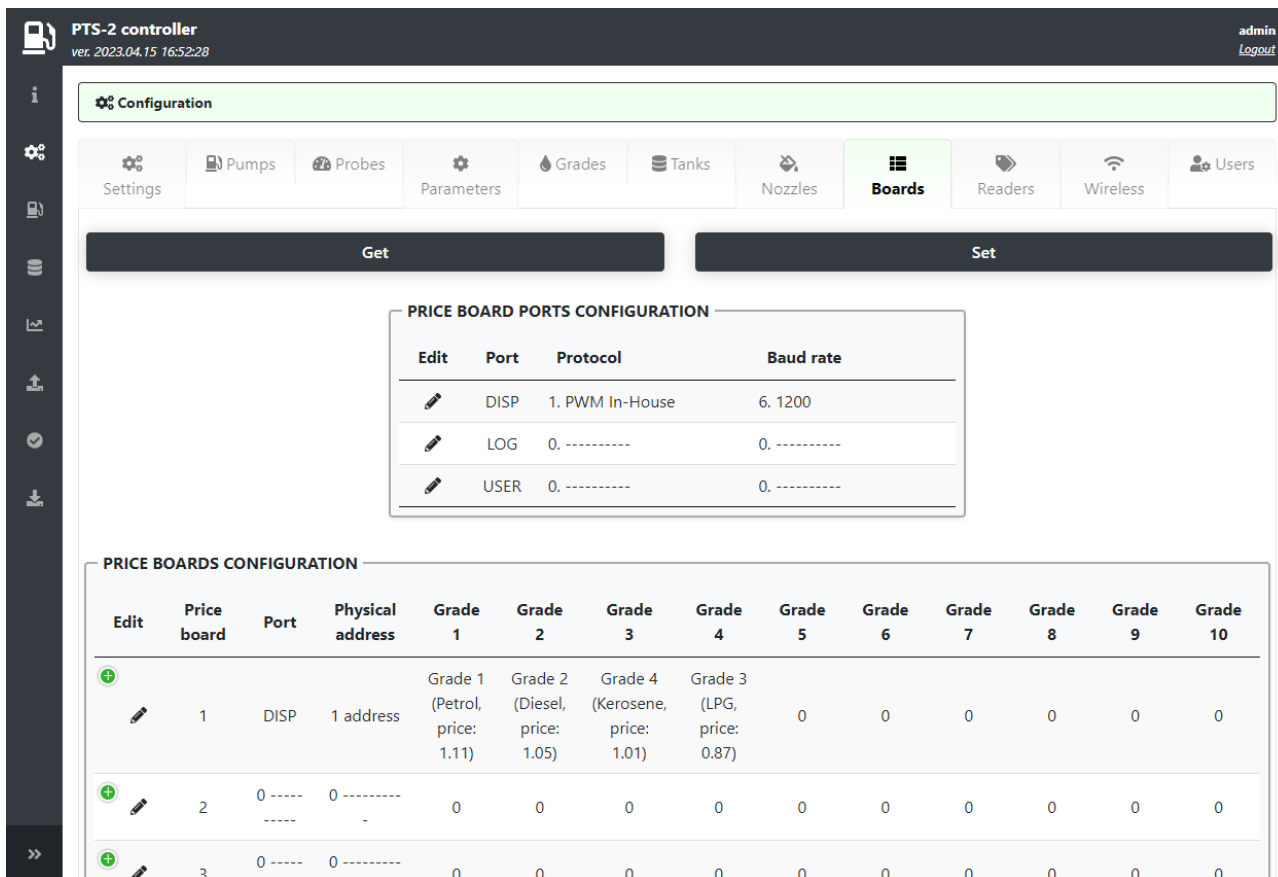

Configuration of ports includes setting of communication protocol and baud rate for each of the ports and also assigning the price boards to each of the ports. Each of the price boards should be also assigned grades, which prices it has to show on its displays (up to 10 prices per the price board). Price boards configuration table also displays price boards' statuses (online state and errors present in communication using icons).

✕

Price board port: DISP

Communication address: 1 address

Fuel grade 1: Grade 1 (Petrol, price: 1.11)

Fuel grade 2: Grade 2 (Diesel, price: 1.05)

Fuel grade 3: Grade 4 (Kerosene, price: 1.01)

Fuel grade 4: Grade 3 (LPG, price: 0.87)

Fuel grade 5: 0

Fuel grade 6: 0

Fuel grade 7: 0

Fuel grade 8: 0

Fuel grade 9: 0

Fuel grade 10: 0

Update

Connected price boards might have specific configuration for communication settings (number of data bits and stop bits, parity). Such parameters for each of the price board ports are configured on [Configuration](#) page > [Parameters](#) tab and there select *Device* as *Controller* and scroll to the section named *PORTS FLEXIBLE COMMUNICATION SETTINGS*:

PTS-2 controller
ver. 2023.04.26 16:41:29
admin
Logout

4. PORTS FLEXIBLE COMMUNICATION SETTINGS

4.1. DISP port interface Sets type of interface used for DISP port.	RS-485 interface	RS-485 interface
4.2. DISP port: use flexible communication settings Sets whether flexible configuration of communication parameters for DISP port should be enabled.	0	<input checked="" type="checkbox"/>
4.3. DISP port: number of data bits Sets number of data bits in communication protocol on DISP port.	8 bits	8 bits
4.4. DISP port: number of stop bits Sets number of stop bits in communication protocol on DISP port.	1 bits	1 bits
4.5. DISP port: parity control Sets parity control in communication protocol on DISP port.	None	None
4.6. LOG port: use flexible communication settings Sets whether flexible configuration of communication parameters for LOG port should be enabled.	0	<input type="checkbox"/>
4.7. LOG port: number of data bits Sets number of data bits in communication protocol on LOG port.	8 bits	8 bits
4.8. LOG port: number of stop bits Sets number of stop bits in communication protocol on LOG port.	1 bits	1 bits
4.9. LOG port: parity control Sets parity control in communication protocol on LOG port.	None	None
4.10. USER port: use flexible communication settings Sets whether flexible configuration of communication parameters for USER port should be enabled.	0	<input checked="" type="checkbox"/>
4.11. USER port: number of data bits Sets number of data bits in communication protocol on USER port.	8 bits	8 bits
4.12. USER port: number of stop bits

After that you need to recheck parameter for each of the price boards on [Configuration](#) page > [Parameters](#) tab and there select *Device* as *Price board*. Parameters are to be checked for each of the price boards individually.

PTS-2 controller foresees specific configuration parameters for each of the price boards. Price board parameters are divided into:

- specific parameters for used price board protocol – such parameters depend on the used communication protocol and are different for different communication protocols
- common parameters, which are same for all price boards regardless of the used communication protocol

Description	Default	Value
1. PRICE BOARD GENERAL SETTINGS		
1.1. Price multiplier for display 1 Sets multiplier for price value for display 1.	x1	x1
1.2. Price multiplier for display 2 Sets multiplier for price value for display 2.	x1	x1
1.3. Price multiplier for display 3 Sets multiplier for price value for display 3.	x1	x1
1.4. Price multiplier for display 4 Sets multiplier for price value for display 4.	x1	x1
1.5. Price multiplier for display 5 Sets multiplier for price value for display 5.	x1	x1
1.6. Price multiplier for display 6 Sets multiplier for price value for display 6.	x1	x1

In common parameters it is possible to configure multipliers for the price displays, which allow to move the displayed price value on price display to left or right direction.

After configuration is done the prices should be shown on the price board and also should updated immediately when fuel grades configuration is updated in the PTS-2 controller (on [Configuration](#) page > [Grades](#) tab).

CONNECTION TO RFID READERS AND AVI SYSTEMS

PTS-2 controller allows to connect same time up to 120 readers and up to 300 dispenser nozzle readers or automatic vehicle identification systems (AVI systems). At this connection of 3 different brands of readers and AVI systems using different communication protocols is possible same time (each of the ports can be adjusted to a separate communication protocol, baud rate and communication settings: number of data bits and stop bits, parity).

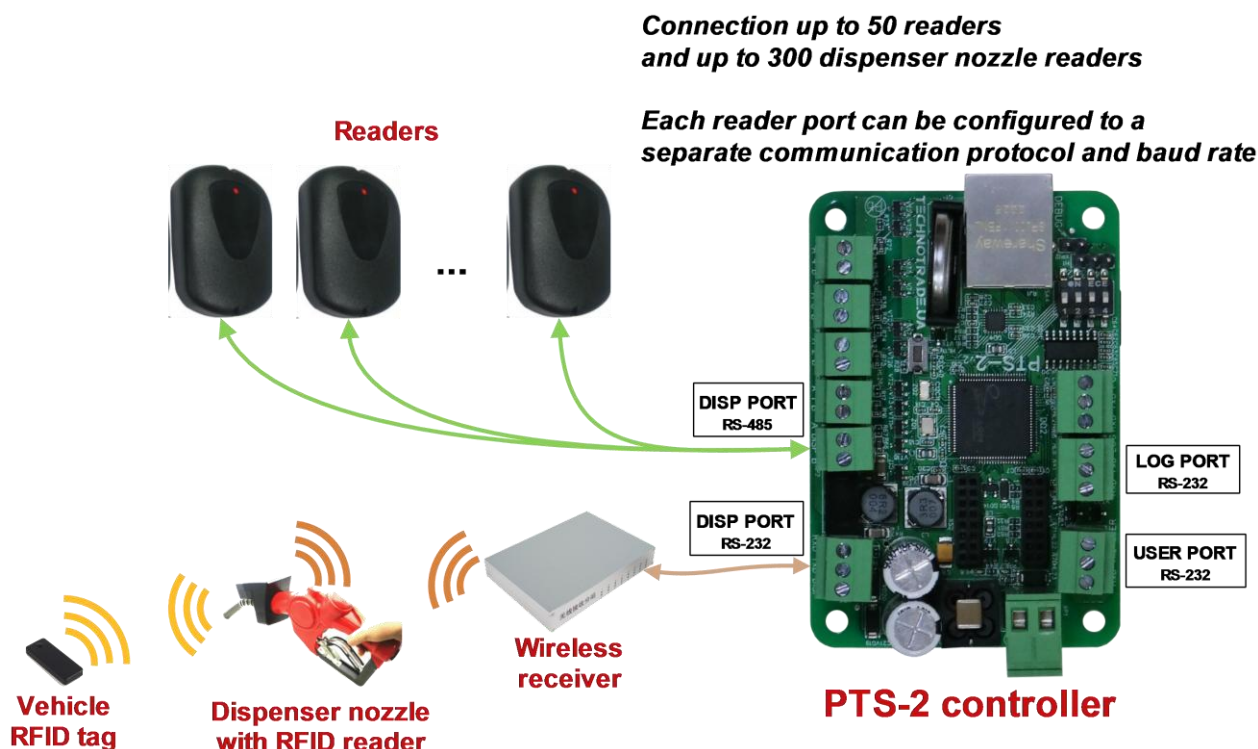

The readers can be used as standalone, so as can be linked to pumps programmatically.

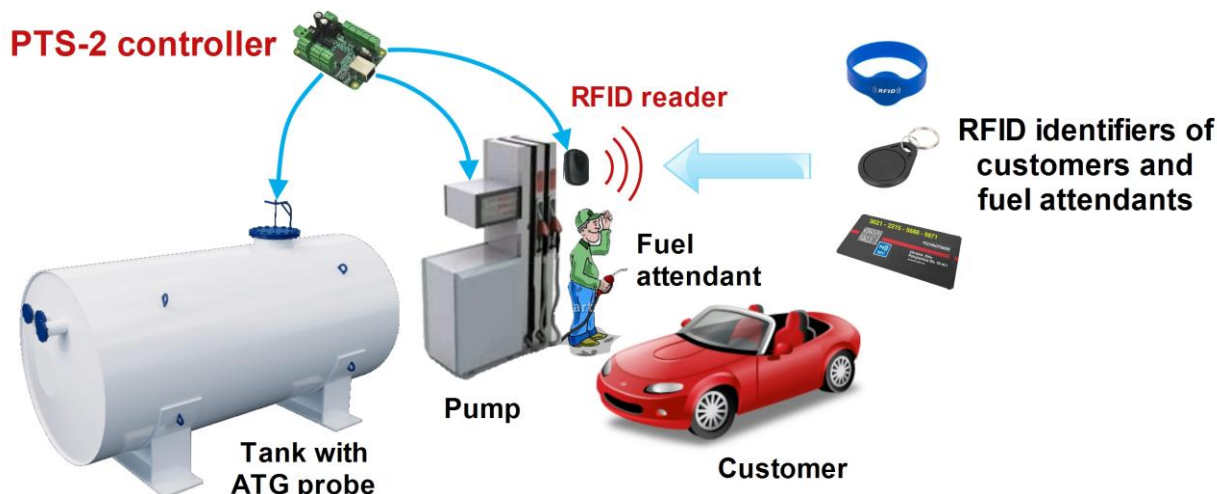

PTS-2 controller allows to read the RFID identifiers (cards, tags, wrist straps, etc.) same time from up to 120 readers. The readers can be used as standalone, so as can be linked to pumps programmatically.

PTS-2 controller provides leading a list of tags for customers and fuel attendants, which allows to verify the customer or fuel attendant before the filling to avoid unauthorized fillings.

In the end of the filling the PTS-2 controller saves information on the performed transactions together with the read tags to the database allowing to track actions of the customer or fuel attendant and view in reports sales performed by each customer or fuel attendant.

Providing the fuel attendants with RFID tags allows to solve many important tasks including:

- Fillings can be done only by authorized fuel attendants having valid RFID tags, so it prevents a possibility to fuel by unauthorized users and thus avoid a possibility of stealing the fuel
- All the filling done by fuel attendants are saved in the PTS-2 controller database, the PTS-2 controller allows to generate reports on sales serviced by each fuel attendant, the management of the petrol station can anytime generate a report on how much cash was received by each fuel attendant during any period
- No need to manually write down totals from pumps at start and end of the working shifts - now these values are automatically recorded by the PTS-2 controller and are shown in the generated reports
- No need to fix fuel attendants for certain pumps and fueling places - now any fuel attendant can service any pump filling, the controller provides exact report information on each fuel attendant activity, which allows to save resources
- Management of petrol station can check activity of the fuel attendants and understand who is more active and who is lazy
- Any attempt to cheat or steal the fuel by the fuel attendant is automatically registered by the PTS-2 controller and shown in reports

PTS-2 controller allows to work with different brands of vehicle identification systems (AVI systems), which allow to automatically identify the vehicle once the pump nozzle is inserted inside the vehicle's tank. These systems are used for 3 main purposes:

- to automatically identify the vehicle without interaction of the driver
- to automatically check the account linked to the vehicle (remains of balance, personal loyalty program or discounter, etc)
- to prevent fuel thefts (filling will not start to a different vehicle and a possibility to cheat during the fueling process is eliminated)



Once the pump nozzle is inserted in the vehicle's tank - the management system can automatically know the vehicle's ID and check its account in order to provide it with its personal discount or loyalty policy and start the fueling process, so all is done automatically without the driver's interaction.

During the filling the PTS-2 controller is constantly checking the vehicle tag and in case if the pump nozzle is removed from the vehicle (in order to steal the fuel by filling a canister or some other vehicle) - then the PTS-2 controller automatically pauses the filling, the filling will be automatically resumed once the nozzle is inserted back into the initial vehicle's tank (when the initial tag is detected again).

PTS-2 controller allows flexible configuration for petrol station to state which pump nozzles are equipped with the AVI system and which are not. It allows to install the AVI system only on part of the dispensers (for example those, which are appointed for the fleet customers).

In the end of the filling the PTS-2 controller saves information on the performed transactions together with the detected vehicle tags to its database allowing to track vehicles in reports and to upload the data to a remote server.

NOTE! Technotrade LLC has a support team and provides customers with remote support in configuration and connection of various readers' and AVI systems' brands for their connection and communication to the PTS-2 controller.

Configuration of price boards is made on [Configuration](#) page > [Readers](#) tab. This tab allows to configure ports for communication with readers, you can configure each of the readers (up to 120) to its own port and assign it a physical address (communication address configured inside the reader). You can configure many readers to the same port. Readers configuration table also displays readers' statuses (online state and errors present in communication using icons).

The screenshot shows the 'Readers' configuration page in the PTS-2 controller web interface. The page has a dark sidebar on the left with various icons. The main content area has a light background with a navigation bar at the top containing tabs for Settings, Pumps, Probes, Parameters, Grades, Tanks, Nozzles, **Readers**, Wireless, and Users. Below the navigation bar are 'Get' and 'Set' buttons. The 'READER PORTS CONFIGURATION' table is as follows:

Edit	Port	Protocol	Baud rate
	DISP	1. VRD-485	4. 9600
	LOG	0.	0.
	USER	0.	0.

Below this is the 'READERS CONFIGURATION' table:

Edit	Reader	Port	Physical address	Pump	Online	Error
	1	DISP	1 address	0		
	2	0	0	0		
	3	0	0	0		
	4	0	0	0		
	5	0	0	0		
	6	0	0	0		

Configuration of ports includes setting of communication protocol and baud rate for each of the ports and also assigning the readers to each of the ports. Each of the readers should be also assigned a specific pump or otherwise can be set to serve any pump if value is set to 0 for field *Pump*:

Edit record
✕

Reader port: DISP ▼

Communication address: 1 address ▼

Pump: 0 ▼

Update

Connected readers might have specific configuration for communication settings (number of data bits and stop bits, parity). Such parameters for each of the reader ports are configured on [Configuration](#) page > [Parameters](#) tab and there select *Device* as *Controller* and scroll to the section named *PORTS FLEXIBLE COMMUNICATION SETTINGS*:

PTS-2 controller
admin
[Logout](#)

4. PORTS FLEXIBLE COMMUNICATION SETTINGS

4.1. DISP port interface Sets type of interface used for DISP port.	RS-485 interface	RS-485 interface ▼
4.2. DISP port: use flexible communication settings Sets whether flexible configuration of communication parameters for DISP port should be enabled.	0	<input checked="" type="checkbox"/>
4.3. DISP port: number of data bits Sets number of data bits in communication protocol on DISP port.	8 bits	8 bits ▼
4.4. DISP port: number of stop bits Sets number of stop bits in communication protocol on DISP port.	1 bits	1 bits ▼
4.5. DISP port: parity control Sets parity control in communication protocol on DISP port.	None	None ▼
4.6. LOG port: use flexible communication settings Sets whether flexible configuration of communication parameters for LOG port should be enabled.	0	<input type="checkbox"/>
4.7. LOG port: number of data bits Sets number of data bits in communication protocol on LOG port.	8 bits	8 bits ▼
4.8. LOG port: number of stop bits Sets number of stop bits in communication protocol on LOG port.	1 bits	1 bits ▼
4.9. LOG port: parity control Sets parity control in communication protocol on LOG port.	None	None ▼
4.10. USER port: use flexible communication settings Sets whether flexible configuration of communication parameters for USER port should be enabled.	0	<input checked="" type="checkbox"/>
4.11. USER port: number of data bits Sets number of data bits in communication protocol on USER port.	8 bits	8 bits ▼
4.12. USER port: number of stop bits	1 bits	1 bits ▼

After that you need to recheck parameter for each of the readers on [Configuration](#) page > [Parameters](#) tab and there select *Device* as *Reader*. Parameters are to be checked for each of the readers individually.

PTS-2 controller foresees specific configuration parameters for each of the readers. Reader parameters are divided into:

- specific parameters for used reader protocol – such parameters depend on the used communication protocol and are different for different communication protocols
- common parameters, which are same for all readers regardless of the used communication protocol

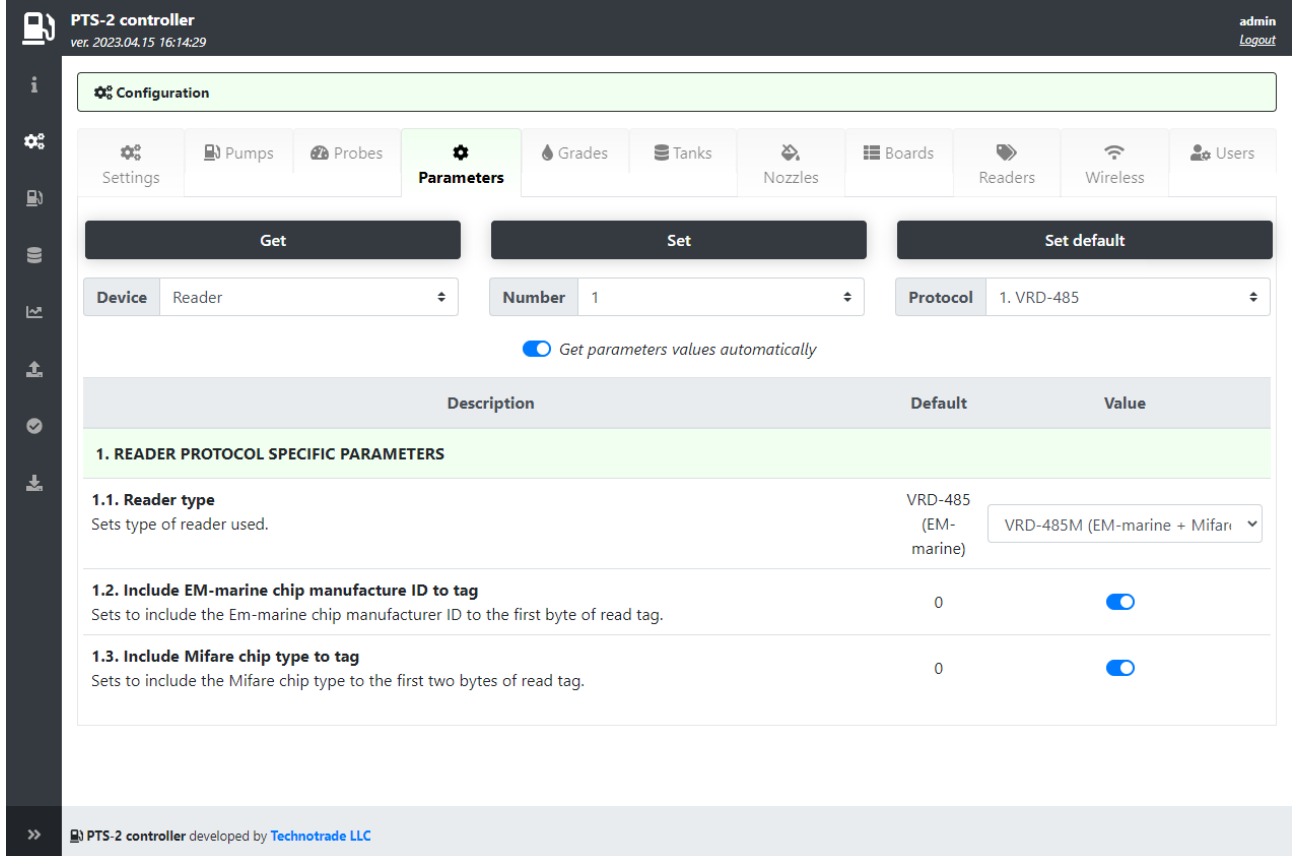

Also, in case of application the automatic vehicles identification (AVI) system – then you might need to additionally configure the nozzle readers installed on nozzles of dispensers. Configuration of nozzle readers' addresses is made in parameters for each pump (it is found on [Configuration](#) page > [Parameters](#) tab, there select *Device* as *Pump*) in section *PUMP NOZZLE READERS SETTINGS FOR AUTOMATIC VEHICLES IDENTIFICATION SYSTEM*. Parameters are to be checked for each of the pumps individually.

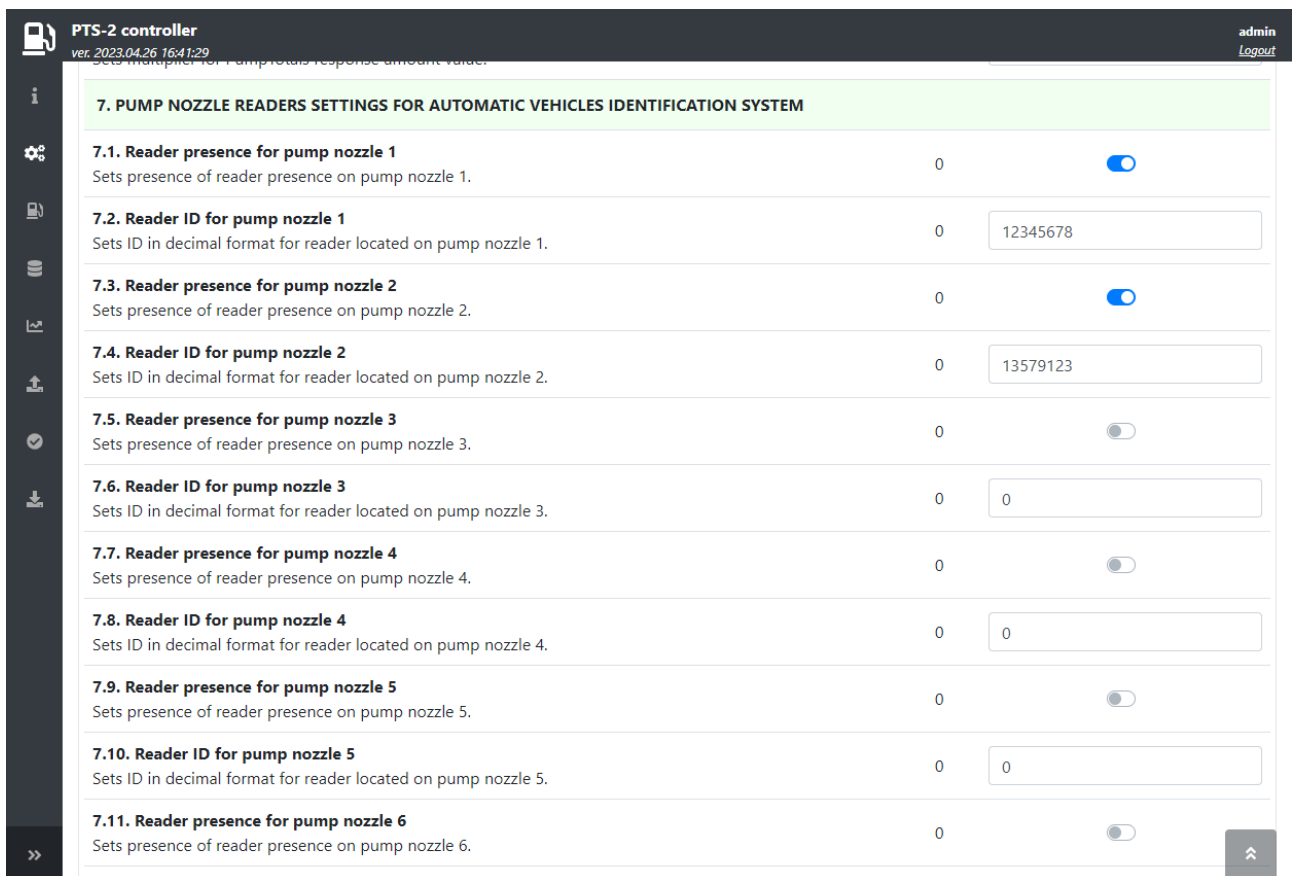

In case if you need to enter the list of valid tags in the PTS-2 controller – then you can make it on *Configuration* page > *Readers* tab in bottom of the page in *Tags list* section:

PTS-2 controller
ver. 2023.10.11 14:22:52

admin
Logout

TAGS LIST

Tags list file: TAGS.CSV: 461 B ([download](#))

Upload new file:

Select file

Automatically read a tag by the reader

Reader 1

Create Edit Delete Copy Excel CSV Print

Search:

ID	Name	Valid
2E00B45DCB	Marry Plum	Yes
3600200EEF	Big Bob	Yes
6789ABCDEF	Joan Nice	Yes
1122334457	Strange person	No
9900AABBEE	Director	Yes
F12352BCF3	Alf Anthony	Yes
12BBA34EFD	Lincy Suss	Yes

Previous 1 Next

Get Set

PTS-2 controller developed by Technotrade LLC

Option *Automatically read a tag by the reader* allows to select a reader from a list and to automatically read the tag identifier from the selected reader when adding or editing the tags.

Each tag configuration contains entering tag ID, tag holder name and validity flag:

Edit record

ID:

Name:

Valid: Yes No

Edit

List of tags is stored in file *Tags.csv* on SD flash disk. It can be downloaded from this page and also uploaded. Structure of tags list file is described in section [Files stored on SD flash disk](#).

There are 2 parameters to be set to make the tag be automatically verified by the PTS-2 controller before the filling starts. These parameters are to be set for each pump (it is found on [Configuration](#) page > [Parameters](#) tab, there select *Device as Pump*) in section *TAG VERIFICATION SETTINGS*. Parameters are to be checked for each of the pumps individually.

The screenshot shows the configuration interface for the PTS-2 controller. The header includes the controller name, version (2023.10.11 14:22:52), and user information (admin, Logout). The main content area is titled '3. TAG VERIFICATION SETTINGS' and contains two sections:

- 3.1. Verify tag in list before authorization**: Description: Sets to automatically verify the user's tag in list of allowed tags before pump authorization. This parameter needs the controller to have tag's readers configured and linked to this pump. The controller will authorize the pump only in case if the tag, read by the reader, linked to given pump, is valid. List of tags is stored inside the controller. Value: 0. Toggle: On.
- 3.2. Keep verifying tag during filling**: Description: Sets to keep verifying the tag brought to the reader during the fuel filling process on the pump. In case if no tag is found or the found tag differs from the tag used at authorization - then the controller should pause or stop the filling process automatically and resume it when the correct tag is brought back to the reader. Value: 0. Toggle: On.

Below these is section '4. TIMER SETTINGS' with one visible item:

- 4.1. Automatically close transaction on pump if no fuel dispensed**: Description: Sets to automatically close transaction on pump after authorization request was sent to it, but no fuel was... Value: 0. Toggle: Off.

These parameters are:

- *Verify tag in list before authorization* – this parameter sets to automatically verify the tag in the list of allowed tags before pump authorization. The controller will authorize the pump only in case if the tag, read by the reader is valid. List of tags is stored inside the controller.
- *Keep verifying tag during filling* – this parameter sets to keep verifying the tag brought to the reader during the fuel filling process on the pump. In case if no tag is found or the found tag differs from the tag used at authorization - then the controller should pause or stop the filling process automatically and resume it when the correct tag is brought back to the reader. This parameter is useful at operation with the AVI system connected to avoid cheating and eliminate a possibility to fill some other capacity or vehicle instead of the previously identified vehicle).

WIRELESS COMMUNICATION

The PTS-2 controller can be connected to all forecourt equipment in a wireless way using a **WFC wireless forecourt communicator**, which allows communication with any brand of dispensers (fuel, LPG, CNG), tank probes and consoles, price poles in a wireless way without a need to put any cables.

WFC has a rich set of electric interfaces on board (various types of current loop interfaces, voltage driven interfaces, RS-485, RS-422, RS-232) suiting to connection of any dispenser brand. WFC has additional port for connection of RFID readers installed on dispensers.

Communication with WFC is done over a secured Wi-Fi network.



The WFC communicator works in conjunction with the PTS-2 forecourt controller, where the WFC communicator provides wireless communication and connection to devices using various hardware interfaces and the PTS-2 controller manages communication with the connected devices (dispensers, ATG consoles and probes, price poles, readers and AVI systems).

At this you can locate a separate WFC communicator for each of the forecourt devices you need to communicate with. Or you can unite several such devices to use the same single WFC communicator if the used communication interface allows it, for example if these devices are using the RS-485 interface and the same communication protocol.

Dimensions of the WFC communicator board are extremely small with a size of a credit card, which makes its suitable for installation inside any third-party hardware.

Detailed information on the WFC communicator can be found on its web-page <https://www.technotrade.ua/wireless-forecourt-communicator>.

AUTOMATIC OPERATION ON SITE

This feature allows the PTS-2 controller to work standalone on the station without any additional management system, providing control over pumps and tanks, saving all data to the database and uploading to a remote server automatically. This feature allows to have completely automatic installations with minimal hardware used on the site. PTS-2 controller guarantees stable application during a long period.

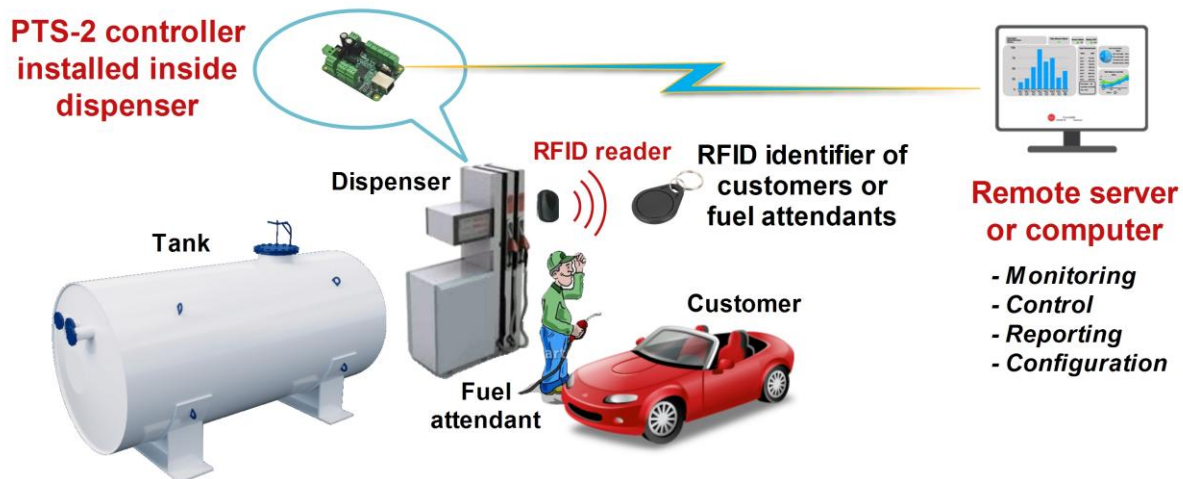

At this PTS-2 controller automatically authorizes pumps and stores all sales to database. Also, the PTS-2 controller tracks all changes of product measurements inside tanks with storing of all changes in database and automatic registration of in-tank deliveries and discharges from tanks.

Fuel attendants could be equipped with the RFID tags used for authorization of fuel dispensers, which allows to avoid unauthorized fillings and to track of which pump sales are done by which fuel attendant.

All database records are automatically uploaded to remote server for subsequent analysis: reconciliation, automatic tanks calibration, detection of leakages and thefts.

PTS-2 controller can be used as IoT device for communication with dispensers and ATG probes, collecting and storing data and uploading to a remote server using encrypted communication.

To set the pumps to automatic mode of operation it is needed to set several parameters in the parameters list for each pump (pump parameters are configured on [Configuration](#) page > [Parameters](#) tab, there select *Device as Pump*), there find a section *PUMP AUTHORIZATION SETTINGS* and set the following:

- Automatically authorize pump on nozzle up
- Automatically close transaction
- Read pump totals automatically

The screenshot shows the 'PTS-2 controller' settings page. At the top, it says 'PTS-2 controller DEBUG' and 'ver. 2023.04.24 13:11:28'. The user is logged in as 'admin'. The main content area is titled '2. PUMP AUTHORIZATION SETTINGS'. It contains six numbered settings, each with a description, a value of '0', and a toggle switch.

Setting ID	Description	Value	Toggle State
2.1. Automatically authorize pump on nozzle up	Sets whether controller should automatically authorize pump on nozzle up detection. Authorization is done to full tank, so preset can be entered from dispenser keyboard.	0	On
2.2. Automatically close transaction	Sets whether transactions should be closed automatically by controller in end of filling.	0	On
2.3. Authorize pump only on nozzle up	Sets whether controller should authorize pumps only on nozzle up. If this parameter is set - then at reception of authorization command from control system on nozzle down controller will wait until the nozzle is taken up on a pump before sending authorization to it.	0	Off
2.4. Automatically stop pump at overfilling	Sets whether stop command should be sent to pump automatically at detection of overfilling.	0	Off
2.5. Ignore repeated authorization	Sets whether repeated authorization command should be ignored. If this parameter is set then controller will ignore any repeated authorization commands to pump if authorization command was already sent to it before.	0	Off
2.6. Read pump totals automatically	Sets to read pumps total counters automatically at connection to pump and after each pump transaction end. If this parameter is set - then the controller will request total counters automatically in end of each dispensing and the control system will receive totals automatically in end of dispensing without a need to request them. Also, in case if the control system requests total counters separately - the controller will send them immediately without spending time to request them from the pump. Also, in case if parameter SAVE PUMP SALES TO SD is set in parameters of controller - then total counters would be also saved to SD with a possibility to generate totals in report on pump transactions.	0	On

Below this section is '3. TAG VERIFICATION SETTINGS' with one visible setting: '3.1. Verify tag in list before authorization'.

In this case the pumps will get authorized automatically once the nozzle is detected to be taken up on it. The fuel attendant is able to enter a preset order on the pump keyboard before taking up a nozzle. Once the nozzle is taken down in the end of the filling the PTS-2 controller will automatically read the totals and close the transaction.

Also, in order to enable saving of the pump records and other things to the database – activate the needed parameters in section *SD FLASH DISK SETTINGS* in a list of parameters for the PTS-2 controller:

The screenshot shows the 'PTS-2 controller' settings page, continuing from the previous one. It shows settings 1.6 and 2. SD FLASH DISK SETTINGS. Setting 1.6 is '1.6. In the end of filling price on pump should be displayed equal to price of the used fuel grade'. Section 2 contains six settings related to saving data to the SD flash disk.

Setting ID	Description	Value	Toggle State
1.6. In the end of filling price on pump should be displayed equal to price of the used fuel grade	Sets whether the price on the pump in the end of filling should be set to default price configured for used fuel grade regardless on what was the real price used for the pump authorization. The fuel grade prices and linkage of the nozzles to fuel grades should be configured in the controller for application of this parameter.	0	Off
2.1. Save pumps sales to SD	Sets whether all pumps sales should be saved to SD flash disk for reports generation.	0	On
2.2. Save zero pump sales to SD	When this parameter is activated - then zero and non-zero pump sales are saved to SD, when this parameter is not activated - then only non-zero pump sales are saved to SD. To save the pump sales a parameter "SAVE PUMPS SALES TO SD" should be enabled.	0	On
2.3. Save tanks measurements to SD	Sets whether all tanks measurements data should be saved to SD flash disk for reports generation.	0	On
2.4. Save GPS data to SD	Sets all GPS data should be saved to SD flash disk for reports generation.	0	Off
2.5. Save system alerts to SD	Sets whether all system alerts should be saved to SD flash disk for reports generation.	0	On
2.6. Keep SD flash disk operation at lower power	Sets whether operation with SD flash disk should work in case of low power detection.	0	Off

Below this section is '3. UNIPUMP PROTOCOL SETTINGS' with one visible setting: '3.1. Not use commands LockRequest and UnlockRequest'.

After this all the pumps transactions will be automatically saved to the database, so you will be able to generate reports for the operation on [Reporting](#) page > [Pumps](#) tab in different views:

- fuel grades summary sales report
- pump nozzles summary sales report
- details sales report

PUMPS TRANSACTIONS REPORT FOR ALL PUMPS FROM 04.04.23 00:00:06 TILL 05.04.23 00:00:06, DEVICE ID: 003F003E3034511631323737

Copy Excel CSV Print

Show 10 entries Search:

#	Date/time start	Date/time end	Pump	Nozzle	Transaction	Price	Filled volume, L	Filled amount	Volume totals, L	Amount totals	User
1	2023.04.04 00:04:31	2023.04.04 00:05:56	9	1 (Diesel)	6647	58.85	25.488	1500.00	97359.809	6315537.08	PTS
2	2023.04.04 00:07:00	2023.04.04 00:07:38	8	1 (Regular)	20272	62.30	3.662	228.14	64728.016	4258621.57	PTS
3	2023.04.04 00:16:47	2023.04.04 00:17:10	11	1 (Regular)	9279	62.30	1.605	100.00	50436.970	3303983.48	PTS
4	2023.04.04 00:18:20	2023.04.04 00:19:22	10	1 (Diesel)	8597	58.85	16.992	1000.00	148213.098	9572737.93	PTS
5	2023.04.04 00:29:23	2023.04.04 00:29:39	8	1 (Regular)	20273	62.30	1.123	70.00	64729.139	4258691.57	PTS
6	2023.04.04 00:30:53	2023.04.04 00:31:16	8	1 (Regular)	20274	62.30	1.605	100.00	64730.744	4258791.57	PTS
7	2023.04.04 00:37:14	2023.04.04 00:37:31	8	1 (Regular)	20275	62.30	0.802	50.00	64731.546	4258841.57	PTS
8	2023.04.04 00:45:33	2023.04.04 00:49:48	10	1 (Diesel)	8598	58.85	82.752	4870.00	148295.850	9577607.93	PTS
9	2023.04.04 00:49:45	2023.04.04 00:50:16	8	1 (Regular)	20276	62.30	2.407	150.00	64733.953	4258991.57	PTS
10	2023.04.04 00:54:11	2023.04.04 00:55:04	10	1 (Diesel)	8599	58.85	16.992	1000.00	148312.842	9578607.93	PTS
Total:							5714.564	342662.98			

Showing 1 to 10 of 969 entries

Previous 1 2 3 4 5 ... 97 Next

Also, if the tanks probes are connected to the PTS-2 controller – reports or tank measurements and in-tank deliveries can be viewer on [Reporting](#) page > [Tanks](#) tab, also tank reconciliation report can be checked on [Pumps and tanks reconciliation](#) tab.

Also, if there are readers or AVI system installed on the petrol station – then it is possible to configure the PTS-2 controller to automatically verify the tags before making the sales as it is explained in [Connection to RFID readers and AVI systems](#) tab.

COMMUNICATION TO REMOTE SERVER

PTS-2 controller has 2 ways for communication with a remote server:

1. Upload of data to remote server, this is done using HTTP requests sent from the PTS-2 controller to a cloud server. The following data can be uploaded by the PTS-2 controller to the remote server (if enabled in settings):
 - registered pump transactions
 - registered tank measurements
 - registered in-tank deliveries
 - registered alert records
 - registered GPS records
 - real-time status of the PTS-2 controller and all connected equipment (pumps, probes, price boards, readers)
 - configuration of the PTS-2 controller

Also, the remote server can send any request in the controller to make any action (for example to authorize a pump) or change any configuration (for example to update prices of the fuel grades or update a list of allowed fuel attendants tags).
2. Full communication between the PTS-2 controller and a remote server, which is done using the WebSocket protocol (according to [RFC 6455](#)) allowing the remote server to get and set configuration, online monitor activity of pumps and tanks, generate reports and others.

In both cases the PTS-2 controller connects to a remote server as a client, so there is no need to have any static IP-address on the place of PTS-2 controller installation.

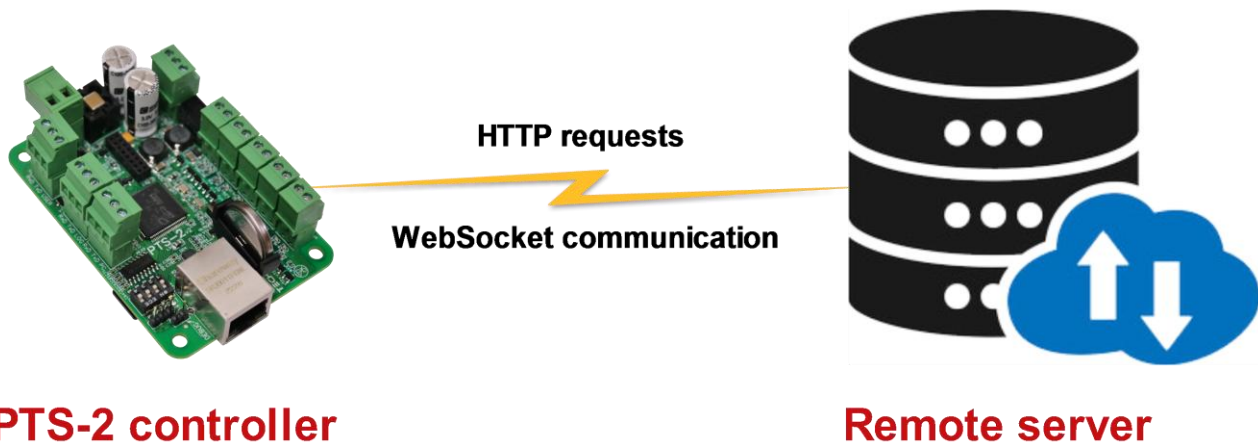

Communication of the PTS-2 controller with a remote server is made using commands and responses described in jsonPTS communication protocol (own proprietary protocol of Technotrade LLC) – see document “*jsonPTS communication protocol specification for PTS-2 controller*” for more information.

The PTS-2 controller allows to upload the following information to a remote server:

1. **Information on each performed pump transaction:**
 - pump sale start date and time
 - pump sale end date and time
 - pump number
 - nozzle number

- fuel grade ID
- transaction number
- pump price
- dispensed volume
- dispensed temperature-compensated volume (volume converted to 15 degrees Celsius)
- dispensed money amount
- value of volume counter in pump on the transaction end
- value of money amount totalizer counter in pump on the transaction end
- value of customer or fuel attendant tag applied for the transaction (the fuel attendant ID card to authorize the pump or the customer's discount/loyalty card)
- ID of a management system authorizing a pump (local POS system or OPT)

Having this data, the remote server is able to:

- generate reports with all details on each pump sales done
- calculate the flow speed of each pump nozzle
- check if there were stealings of fuel done through authorized sales without the controller control (by the pump totalizers counters, which are non-erasable and non-resettable and are incremented regardless the transaction is done in manual mode or automatically, so in case if the totalizers counters were incremented more than a sale done - then someone was doing a filling when a pump is in manual mode, which might be a theft)
- decide which pump is more attractive and more productive
- others

2. Information on each registered tank measurement (the PTS-2 controller uploads the tank measurements data to a remote server each time it detects a change in the product height):

- date and time of measurement
- tank number
- probe error
- alarms present (products height low or high, water height high)
- product height value
- water height value
- product temperature value
- product volume value
- water volume value
- tank ullage volume value
- product temperature-compensated volume value
- product density value
- product mass value

Having this data, the remote server is able to:

- have online data for each tank
- have statistics for each tank usage with a possibility to make forecasting for future needs
- if combined with data on pumps sales from the tank the remote server is able to generate reports on reconciliation meaning to see how much fuel has to be stored in the tank on some moment and how much is actually stored there and thus to understand if there is a possible leakage or thefts from the tank.
- others

3. Information on each registered in-tank delivery (the PTS-2 controller itself monitors tanks for in-tank deliveries, saves them to database and uploads to a server):

- date and time of in-tank delivery start
- date and time of in-tank delivery end
- tank number
- product height value on in-tank delivery start
- product height value on in-tank delivery end
- water height value on in-tank delivery start
- water height value on in-tank delivery end
- product temperature value on in-tank delivery start
- product temperature value on in-tank delivery end
- product volume value on in-tank delivery start
- product volume value on in-tank delivery end
- product temperature-compensated volume value on in-tank delivery start
- product temperature-compensated volume value on in-tank delivery end
- product density value on in-tank delivery start
- product density value on in-tank delivery end
- product mass value on in-tank delivery start
- product mass value on in-tank delivery end

Having this data, the remote server is able to understand how much fuel was received in each tank.

4. Found errors and alarms:

- detected pumps offline status
- detected pumps errors
- detected probes offline status
- detected probes errors
- detected probes alerts (critical high product height, high product height, low product height, critical low product height, high water height)
- detected tanks leakages
- detected tanks probes floats stuck
- detected price-boards offline status
- detected price-boards errors
- detected readers offline status
- detected readers errors
- operation time of the controller
- detected absence of power supply
- low battery voltage
- high CPU temperature
- others

Having this data, the remote server can instantly alarm technical personnel about the found problems to quickly solve them and thus keep the petrol stations work stable and safe.

5. GPS tracking records (in case if the PTS-2 controller is installed inside a fuel delivery truck):

- date and time of GPS record
- fuel track latitude value with North/South indicator

- fuel track longitude value with East/West indicator
- fuel track speed over ground
- fuel track course over ground

Having this data, the remote server can display location of the fuel track on the map with indication what is its speed and height over ground. Also, it can know in which places the fuel delivery truck made fillings and also product level changes in tank were detected (as a mean to define possible stealing of fuel along the fuel delivery truck movement).

6. Online realtime status of each pump (meter), tank probe, GPS receiver, alerts and the PTS-2 controller: having this information the remote server is able to know everything happening realtime on the site. Data is sent each second or faster, the server software can use its own algorithms for calculation of various indicators as it was connected to the forecourt equipment itself locally.

7. PTS-2 controller configuration: the remote server is able to remotely receive configuration from the PTS-2 controller and also to update the configuration in the PTS-2 controller. As an example, the remote server having sent the fuel grades prices update request to the PTS-2 controllers will automatically update of prices on the pumps and in the price boards on the whole network of petrol stations.

Configuration of communication with remote server is done on [Configuration](#) page > [Settings](#) tab in **REMOTE SERVER SETTINGS** section.

The screenshot displays the 'REMOTE SERVER SETTINGS' configuration page in the PTS-2 controller interface. The page is organized into several sections:

- Server IPv4 address:** A text input field containing '0.0.0.0'. Below it, a note states: 'Sets IP-address in IPv4 in format xxx.xxx.xxx.xxx. If there is no static IP-address available - then set here value 0.0.0.0 and below set the server domain name.'
- Domain name:** A text input field containing 'technotrade.ua'. Below it, a note states: 'Domain name (if exists)'
- Server user:** A dropdown menu showing 'admin'. Below it, a note states: 'Credentials for remote server access are taken from user configuration'. There is also a toggle switch for 'Use device identifier as login' which is currently off.
- Timeout of server response:** A text input field containing '1'. Below it, a note states: 'Sets the maximum period in seconds to wait for a message from the server (response in case of data upload data or a new request in case of WebSocket communication)'
- Data upload section:**
 - Upload pump transactions:** A toggle switch that is turned on (blue).
 - Server request URI:** A text input field containing 'jsonPTS'. Below it, a note states: 'Server request URI without starting slash'.
 - At the bottom of this section, it shows 'Uploaded records number: 5' with a 'Reset' button, and 'Total records number: 5'.
- Websocket communication section:**
 - Use Websocket communication:** A toggle switch that is turned off (grey).
 - Server request URI:** An empty text input field. Below it, a note states: 'Server request URI without starting slash'.

Configuration includes filling of the following obligatory fields common for data upload requests and WebSocket communication:

- **Server IPv4 address** – set here a static IP-address of the remote server or leave value 0.0.0.0 if the server does not have a static IP-address

- *Domain name* – domain name of the server if the server has it, if no – leave this field empty. If the remote server does not have a static IP-address – then the PTS-2 controller can resolve the domain name into current IP-address, for this a correct DNS server should be configured in section *NETWORK SETTINGS* on [Configuration](#) page > [Settings](#) tab.
- *Server user* – to access the remote server there should be user credential saved in the PTS-2 controller. PTS-2 controller stores all users on [Configuration](#) page > [Users](#) tab. You need to select here the user, which credentials should be used for access to the remote server.
- *Timeout of server response* – time to wait a response from the server

Data upload settings allow to select the following options:

1. **Upload pump transactions** – checkbox to allow upload each pump sale and the unique request identifier (URI) to send the request to this server. There is a total counter of records present in controller and counter of records already uploaded to server, which is possible to reset to make the controller upload them again to the server.

NOTE! To make this option work the controller should be configured to save pump transactions to SD flash disk, which is configured in parameters for the controller on [Configuration](#) page > [Parameters](#) tab, there select *Device* as *Controller*.

2. **Upload tank measurements** – checkbox to allow upload each tank measurement change and the unique request identifier (URI) to send this request to the server. There is a total counter of records present in controller and counter of records already uploaded to server, which is possible to reset to make the controller upload them again to the server.

NOTE! To make this option work the controller should be configured to save tank measurements to SD flash disk, which is configured in parameters for the controller on [Configuration](#) page > [Parameters](#) tab, there select *Device* as *Controller*.

3. **Upload in-tank deliveries** – checkbox to allow upload each registered in-tank delivery and the unique request identifier (URI) to send this request to the server. There is a total counter of records present in controller and counter of records already uploaded to server, which is possible to reset to make the controller upload them again to the server.

NOTE! To make this option work the controller should be configured to save tank measurements to SD flash disk, which is configured in parameters for the controller on [Configuration](#) page > [Parameters](#) tab, there select *Device* as *Controller*. Also, a parameter to enable in-tank deliveries should be configured for each probe, which is configured on [Configuration](#) page > [Parameters](#) tab, there select *Device* as *Probe*.

4. **Upload GPS records** – checkbox to allow upload each registered GPS record and the unique request identifier (URI) to send this request to the server. There is a total counter of records present in controller and counter of records already uploaded to server, which is possible to reset to make the controller upload them again to the server.

NOTE! To make this option work the controller should be configured to save GPS data to SD flash disk, which is configured in parameters for the controller on [Configuration](#) page > [Parameters](#) tab, there select *Device* as *Controller*. Also, the controller should be equipped with the GPS module and usage of the GPS module should be enabled in parameters for the controller, check how it is done in section [GPS module](#).

5. **Upload alerts** – checkbox to allow upload each registered alert record and the unique request identifier (URI) to send this request to the server. There is a total counter of records present in controller and counter of records already uploaded to server, which is possible to reset to make the controller upload them again to the server.

NOTE! To make this option work the controller should be configured to save alert records to SD flash disk, which is configured in parameters for the controller on [Configuration](#) page > [Parameters](#) tab, there select *Device* as *Controller*. Also, some of the alerts are configured for tanks on [Configuration](#) page > [Tanks](#) tab.

6. **Upload configuration** – checkbox to allow upload PTS-2 controller configuration and the unique request identifier (URI) to send this request to the server. New PTS-2 controller configuration is automatically uploaded to a remote server once any change in configuration is made.
7. **Upload status** – checkbox to allow upload PTS-2 controller status and all equipment connected statuses to a remote server record and the unique request identifier (URI) to send this request to the server. There is a setting for a period to send status request to the remote server.

Settings of data upload also include configuration of

- Server port, where to send the requests
- Secret key, which to use in order to form message signature sent together with a request to the server used to guarantee that the message came to the server originally from the PTS-2 controller (not from some other instance) and also that the message was not changed anyhow while sending to the server (by the man-in-the-middle)

The screenshot shows the configuration page for the PTS-2 controller. The page title is "PTS-2 controller" with version "ver. 2023.04.12 13:24:54" and a user "admin" is logged in. The "Upload status" section is active, indicated by a blue toggle switch. Below this, there are several input fields: "Server request URI" is set to "jsonPTS", "Period between uploading status requests in seconds" is set to "1", "Server port" is set to "80", and "Secret key" is masked with dots. A checkbox for "Update previously entered value" is also checked. At the bottom, there are "Get" and "Set" buttons, and a green checkmark indicates that the "Server communication status" is successful.

Websocket communication settings include to select the following:

- checkbox to enable Websocket communication
- unique request identifier (URI) to send this request to the server
- server port, where to send the requests
- reconnection period to server – sets a reconnection period to server after previous communication was closed in seconds

Resolving possible problems in communication to a remote server

In case if there are any problems in communication with the remote server – it is possible to check for a possible reason in the log. For this you need to enable logging controller in section *LOGGING SETTINGS* enable an option *Extended logging for data upload to remote server* on [Configuration](#) page > [Parameters](#) tab, there select *Device as Controller*.

The screenshot shows the configuration page for the PTS-2 controller. The page title is "PTS-2 controller" with version "ver. 2023.04.26 18:11:13" and a user "admin" is logged in. A message at the top states: "communication interruption at control using DART input protocol" is enabled). The settings are organized into sections:

- 8. LOGGING SETTINGS**
 - 8.1. Extended logging for operation in automatic mode**: Sets extended logging when the controller is configured to work automatically with pumps. Value: 0. Toggle: Off.
 - 8.2. Extended logging for data upload to remote server**: Sets extended logging for data upload to a remote server. Value: 0. Toggle: On.
- 9. READERS SETTINGS**
 - 9.1. Timeout to store last tag read, sec**: Sets timeout in seconds to store last tag read by the reader when it is configured for the pump(s). Value: 1. Input field: 1.
- 10. NON-ADDRESSABLE INTERFACE CONVERTERS OPERATION SETTINGS**
 - 10.1. Pump port 1 operation through non-addressable interface converter**: Sets whether pumps on pump port 1 are connected through non-addressable interface converter. Value: 0. Toggle: Off.
 - 10.2. Pump port 2 operation through non-addressable interface converter**: Sets whether pumps on pump port 2 are connected through non-addressable interface converter. Value: 0. Toggle: Off.
 - 10.3. Pump port 3 operation through non-addressable interface converter**: Sets whether pumps on pump port 3 are connected through non-addressable interface converter. Value: 0. Toggle: Off.
 - 10.4. Pump port 4 operation through non-addressable interface converter**: Sets whether pumps on pump port 4 are connected through non-addressable interface converter. Value: 0. Toggle: Off.
 - 10.5. Pump 1 non-addressable interface converter pump port number**: Sets a pump port number, to which pump 1 is connected in non-addressable interface converter. Value: Not set. Dropdown: Not set.
 - 10.6. Pump 2 non-addressable interface converter pump port number**: Sets a pump port number, to which pump 2 is connected in non-addressable interface converter. Value: Not set. Dropdown: Not set.
 - 10.7. Pump 3 non-addressable interface converter pump port number**: Value: Not set. Dropdown: Not set.

After this option is enabled, download a log file named SERVER.LOG from [Device Information](#) page, it contains records on each session of communication with a remote server.

Test of communication with a remote server

In order to test and see how the PTS-2 controller is uploading the data to a remote server you can use a test server of Technotrade LLC company.

For this set the following configuration in your PTS-2 controller in *REMOTE SERVER SETTINGS* section (see images below):

- **Server IPv4 address:** 0.0.0.0
- **Domain name:** technotrade.ua
- **Server user:** admin (default user)
- **Timeout of server response:** 1
- **Upload status:** enable, set URI *jsonPTS* and set period for uploading status requests to 1 second
- **Server port:** 80
- **Secret key:** leave this field empty and set a checkbox to update previously entered value

Also, make sure that the PTS-2 controller is connected to the network, which has connection to Internet and check that in section *NETWORK SETTINGS* you have correctly configured the fields:

- Gateway, which should match the gateway of the network router
- DNS server, which can resolve the domain name into IP-address (you can use default values 8.8.8.8 and 8.8.4.4)

The screenshot displays the web interface of a PTS-2 controller. At the top, it shows 'PTS-2 controller' with version '2023.09.20 17:20:16' and a user 'admin' with a 'Logout' link. Below this are 'Get' and 'Set' buttons. The main section is titled 'REMOTE SERVER SETTINGS' and contains several configuration fields:

- Server IPv4 address:** A text input field containing '0.0.0.0'. Below it is a description: 'Sets IP-address in IPv4 in format xxx.xxx.xxx.xxx. If there is no static IP-address available - then set here value 0.0.0.0 and below set the server domain name.'
- Domain name:** A text input field containing 'technotrade.ua'. Below it is the label 'Domain name (if exists)'.
- Server user:** A dropdown menu showing 'admin'. Below it is the text 'Credentials for remote server access are taken from user configuration' and a toggle switch for 'Use device identifier as login' which is currently off.
- Timeout of server response:** A text input field containing '1'. Below it is the text 'Sets the maximum period in seconds to wait for a message from the server (response in case of data upload data or a new request in case of WebSocket communication)'.

At the bottom, there are two summary boxes:

- Data upload:** Contains the heading 'Upload pump transactions' and the text 'Sets polling by the controller to remote server for upload of performed pump transactions'.
- Websocket communication:** Contains the heading 'Use Websocket communication' and the text 'Sets to use communication between the controlles and a remote server using Websocket protocol'.

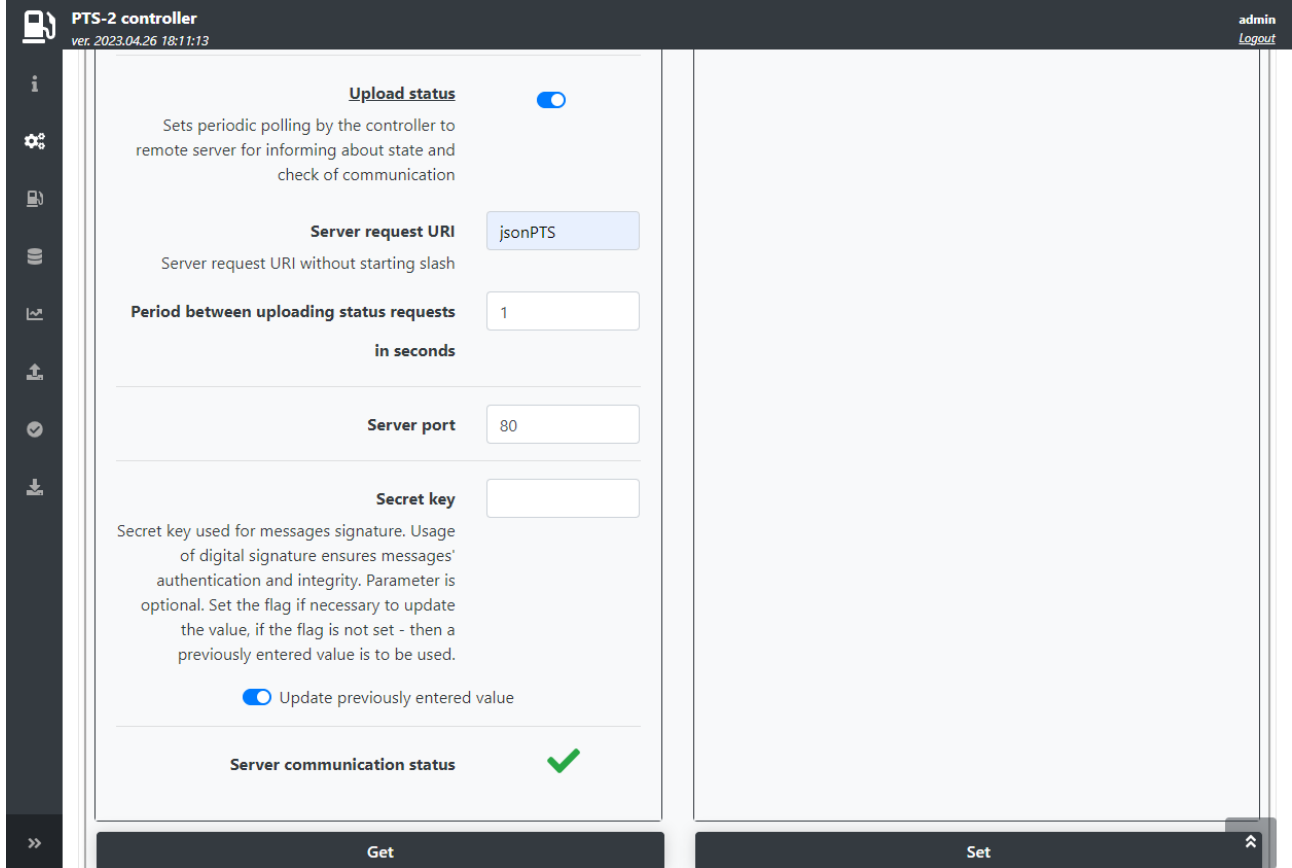

After that is done you should see a green checkbox shown in bottom of the REMOTE SERVER SETTINGS section meaning that the communication is established well. If there a red mark shown – then something is made not correctly, please recheck all the settings or try to check the logs for what can be a reason for the problem as it is described in section [Resolving possible problems in communication to a remote server](#).

After that is done go to website <https://www.technotrade.ua/PTS2/Status?PtsId=xxxxxxxxxxxxxxxxxxxxxxxx>, where xxxxxxxxxxxxxxxxxxxxxxx is the device identifier of your PTS-2 controller, which you can find on [Device information](#) page. For example, if your PTS-2 controller device identifier is 003B00265030500420303531 – then the address should be <https://www.technotrade.ua/PTS2/Status?PtsId=003B00265030500420303531>.

You should see status of your PTS-2 controller, which should be automatically updated each second:

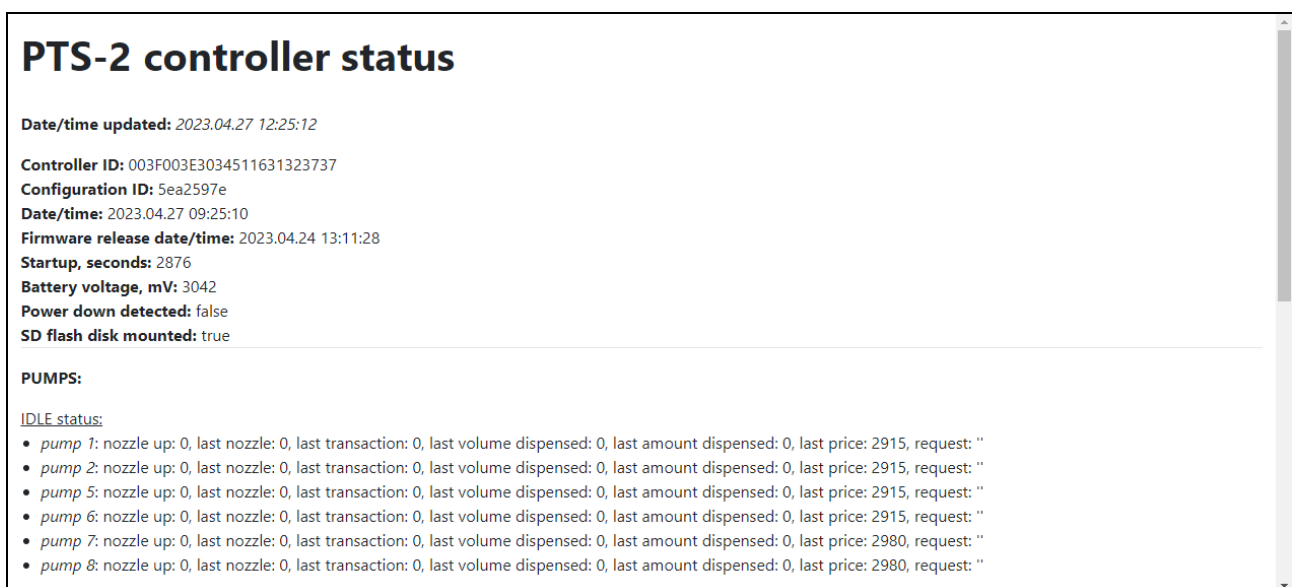

FUEL DELIVERY TRUCKS CONTROL AND GPS TRACKING

PTS-2 controller already supports operation with most popular brands of electronic register meters used on fuel delivery trucks including:

- Gilbarco Veeder Root EMR3 and EMR4
- Total Control Systems TCS 3000
- Liquid Controls LectroCount LCR II, LCR 600, LCR iQ
- Satam Equalis
- IPT
- Yokogawa Rotomass
- other brands

PTS-2 controller can be equipped with a GPS module for tracking of fuel tankers' location:

- tracking of the present location
- tracking of the whole route covered for specified period
- tracking of the fuel level in tanks while the fuel tanker was moving on route
- tracking of places, where fuel level in tanks was changed (tank should be equipped with the probe)
- tracking of places, in which fuel was dispensed through the flowmeter

Having this information, it is possible to know present location of the fuel tanker on the route and the, most important, to know possible frauds done with fuel while the tanker is on the route because PTS-2 controller records GPS places if any change of fuel level in tank is done, PTS-2 controller automatically sends this data to a remote server for processing and analysis.

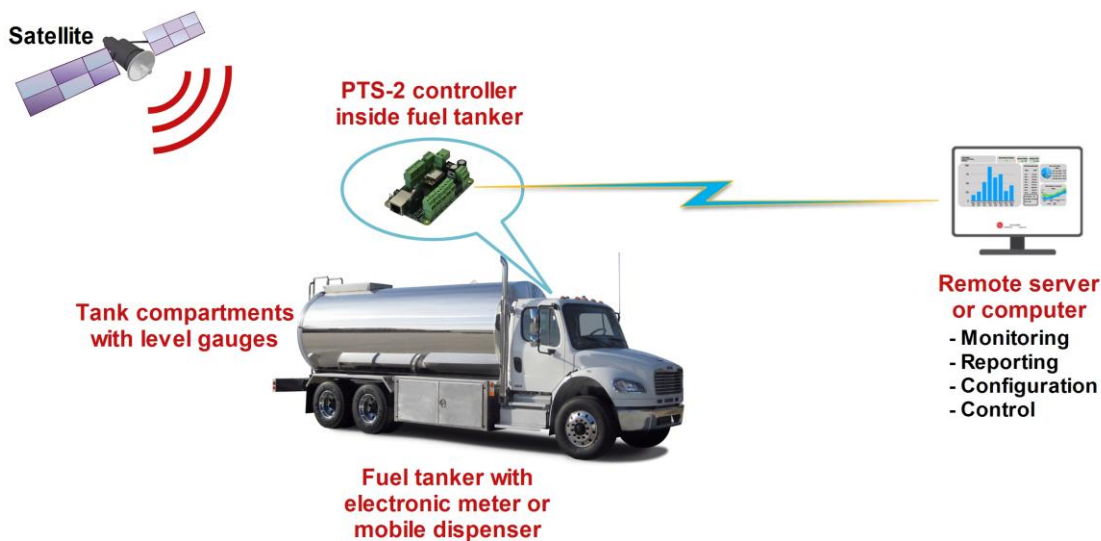

At this, PTS-2 controller automatically accounts all the dispensing performed, with saving to local database and upload to a central server. Additionally, PTS-2 controller can automatically calculate temperature-compensated volume of dispensed fuel if such option is not provided by the meter used.

If the fuel truck has tanks equipped with ATG system – then PTS-2 controller will automatically detect fillings made from tanks and deliveries made to tanks with saving to local database and upload to a central server.

It is possible to evaluate fuel frauds or leakages done while the tanker is on the route as PTS-2 controller records GPS coordinates and controls any change with fuel levels in tank. Based on these records you can define exact location, where fuel removals or receptions happened without allowed registration.

Please read more about GPS module and its configurations in [GPS module](#) section.

CONVERSION BETWEEN PUMPS COMMUNICATION PROTOCOLS

PTS-2 controller can work as a protocols converter converting between fuel dispensers' communication protocols and also between ATG systems and probes communication protocols.

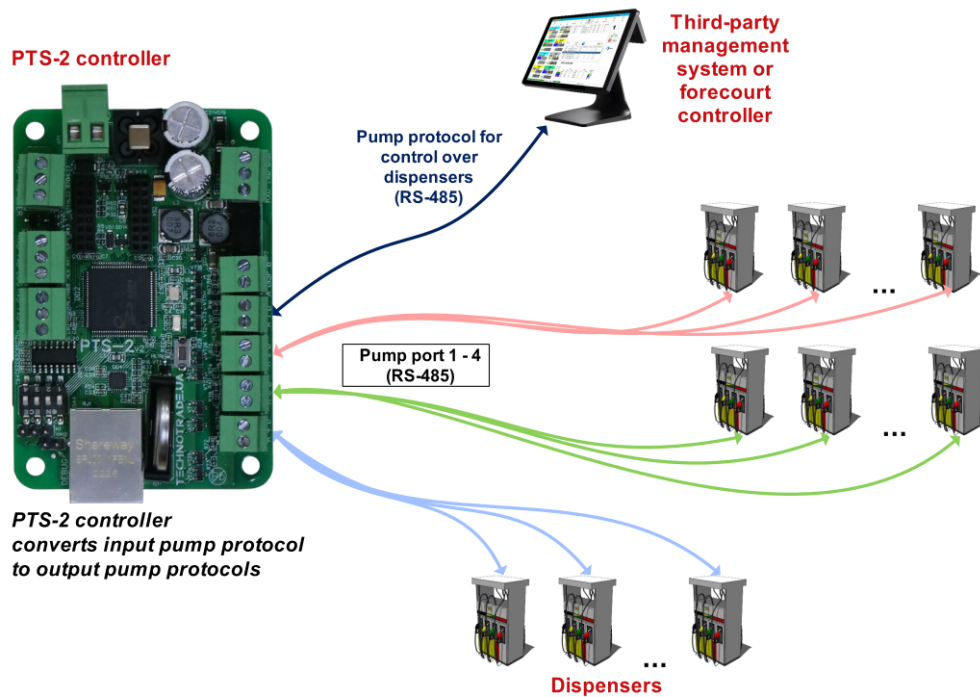

In case if the POS system already knows some open communication protocol of dispensers – then it can use the PTS-2 controller for its conversion to any other pump protocols without any additional integration.

Control over dispensers can be done in parallel from many management systems connected through pump ports, PC port and Ethernet port in the PTS-2 controller. The PTS-2 controller internally tracks which control system locks control over dispensers.

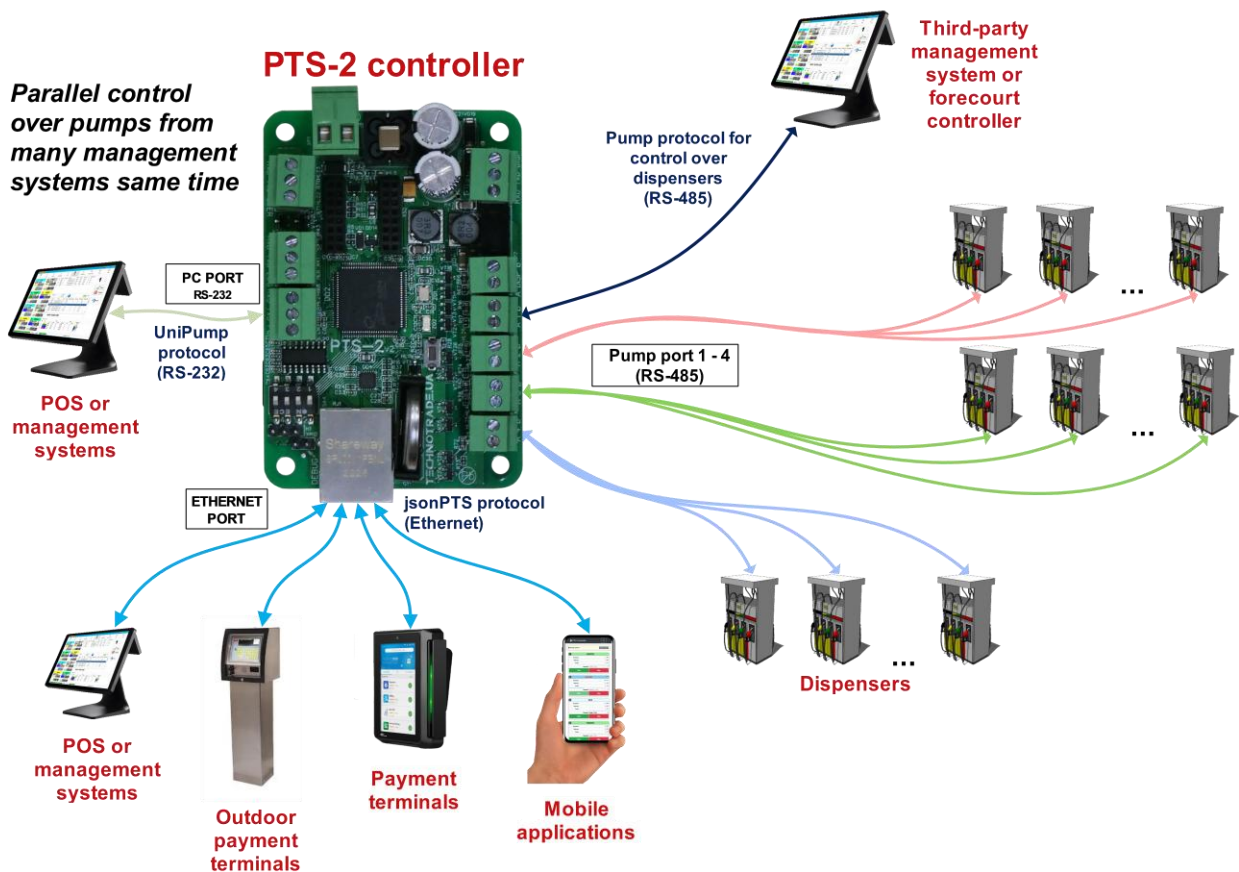

CONVERSION BETWEEN PROBES COMMUNICATION PROTOCOLS

PTS-2 controller can work as a protocols converter converting between fuel dispensers' communication protocols and also between ATG systems and probes communication protocols.

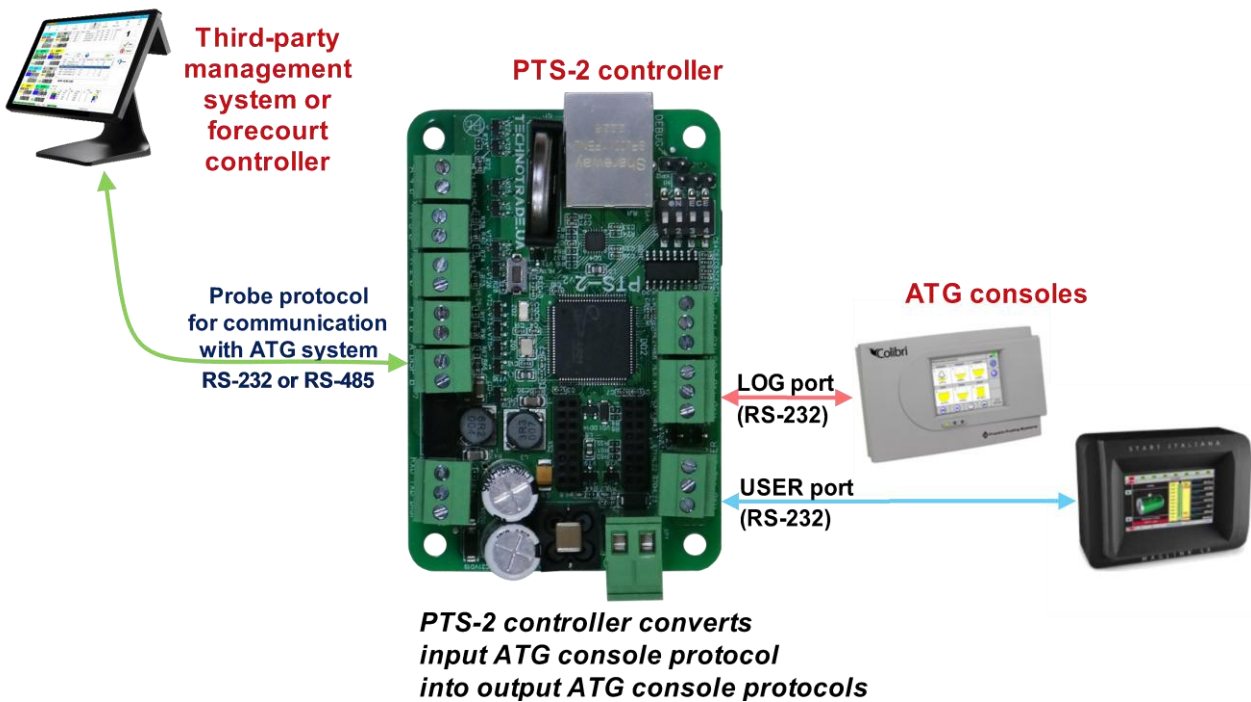

In case if the POS system already knows some open communication protocols of ATG consoles then it can use PTS-2 controller for its conversion to any other ATG console or probe protocols without any additional integration.

Control over tanks can be done in parallel from many management systems connected through probe ports, PC port and Ethernet port in the PTS-2 controller.

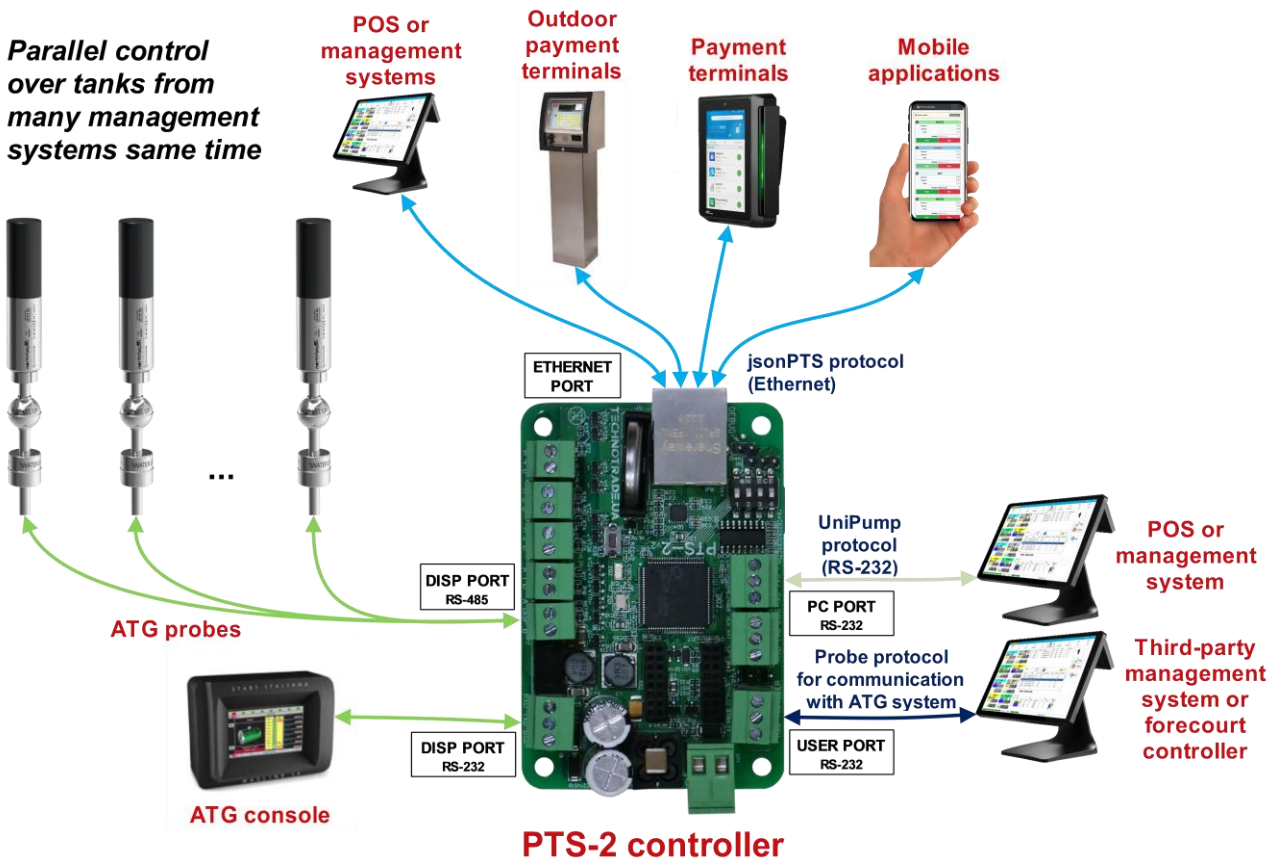

MONITORING OVER PETROL STATION ACTIVITY AND ALERTS

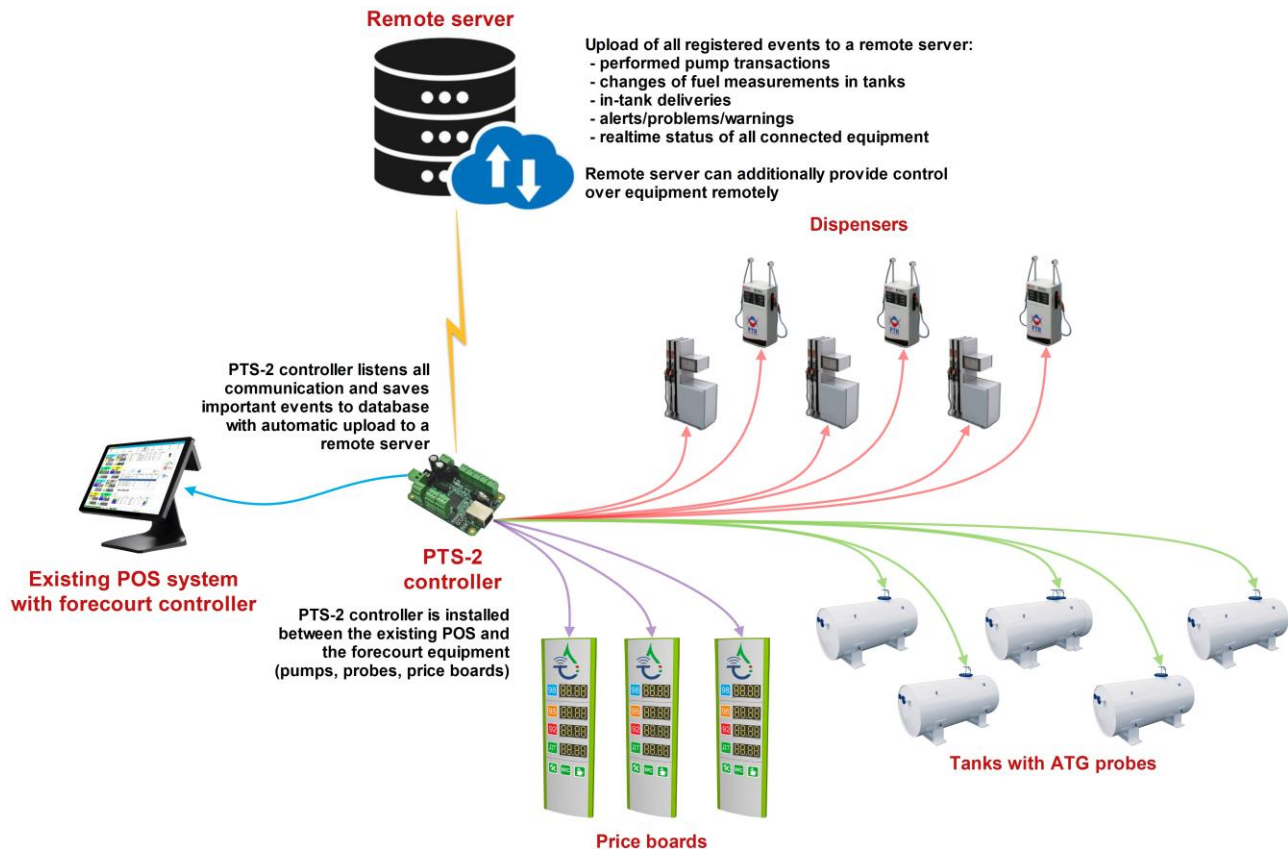

In case if there is an existing POS system already installed on the station – then the PTS-2 controller allows to monitor operation of the fuel dispensers, tanks and price-boards (and optionally to control the sales when required).

PTS-2 controller can be installed on already automated petrol stations in between the POS/controllers and dispensers, probes, price boards. The PTS-2 controller will pass through all communication with saving of all important events to its database with automatic upload to a remote server:

- performed pump transactions
- changes of fuel measurements in tanks
- in-tank deliveries
- alerts/problems/warnings
- realtime status of all connected equipment

All this data is automatically collected and uploaded to a remote server for reporting and analysis. Remote server also can provide control over all the forecourt equipment through the PTS-2 controller.

INSTALLATION REQUIREMENTS

Before making support for installation of the fuel management system equipment (later named as equipment) on the petrol station, it is important to make sure that the power supply cables and information cables used on the station are placed correctly and the power supply to equipment is done in a correct way to prevent any malfunction or damage of the equipment during operation. Here we listed the base requirements covering the aspects for putting the cables and feeding the equipment.

1. Requirements to power supply

Power supply of the equipment should be done from a separate power supply with a built-in filter of radio frequency interferences and limiter of high voltage pulse interferences. Power supply should have a power safety factor of 1.5.

In case of emergency switching off the equipment power supply or in case of power voltage exceeding its permitted ranges the equipment may switch off with loss or corruption of data and with possible damage of hardware and software, in order to prevent it the power supply of all equipment should be made from an uninterruptible power supply source (UPS). UPS should be of continuous action (online) and should work with double conversion with output voltage regulation. UPS should have a power safety factor of 1.5. It is recommended to feed the fuel management equipment and the dispenser pump heads (only pump heads, not the other components) from the same UPS.

Filter of radio frequency interferences and limiter of high voltage pulse interferences should be used for feeding equipment from UPS. UPS unit should be connected to a separate three-pole socket fed through the three-wire feeder (phase, neutral, ground wires) with insulated neutral from a dedicated circuit breaker of switchboard. Phase wire of the feeder should not have any other active load consumers, which are sources of interferences (for example motors, air conditioners, refrigerators, etc.). For protection of equipment and UPS from secondary effects of atmospheric electricity (lightning) it is required to install high-voltage arresters (dischargers) at the transformer substation or on poles of power lines.

WARNING! Manufacturer guarantees reliable and stable operation of hardware products only at compliance with these requirements. In case of absence of uninterruptible power supply or incorrect wiring of equipment to it any claims to malfunction of equipment are not accepted.

2. Requirements to grounding

In the switchboard the ground wire of feeder socket should be connected to the grounding screw, which should be connected by means of welding with a protection grounding circuit of petrol station by steel wire with a diameter of not less than 5 mm. Protection grounding circuit of petrol station should correspond to safety requirements and be separated from the station lightning protection circuit. Distance from the nearest electrode of protection grounding circuit to electrode of lightning protection circuit must be at least 10 meters. Resistance of the protection grounding circuit should be no more than 4 Ohms and must be confirmed by the test report. Length of wires from the switchboard to the nearest electrode of protection grounding circuit should not exceed 15 meters. Metal cases of the dispensers should be grounded.

3. Requirements to laying of cable communications

Laying of power and information wires to dispensers should be done in separate pipes with distance of not less than 0.3 meters between each other. For informational wires (current loops, RS-485, other interfaces) it is recommended to use shielded twisted-pair cables, recommended types – SFTP CAT 5E or SFTP CAT 6. The cable shield must be connected to the ground connector on one side only – on the side of the dispenser.

4. Requirements to connection of ATG probes

Connection of ATG probes installed inside the tanks should be done only with provision of required safety measures:

- in case if probes have explosion-proof protection – then armored cables and explosion-protected junction boxes should be used
- in case if probes have intrinsic safety – then connection should be performed through suitable safety barriers

NOTE! Technicians putting the power and information wires and making electrical connections should have corresponding qualifications and allowances/certifications to make such works.

PTS-2 CONTROLLER SOFTWARE DEVELOPMENT KIT (SDK)

PTS-2 controller SDK appointment



PTS-2 controller SDK (Software Development Kit) is intended for developers of POS management software for petrol stations that needs to provide control fuel dispensers and ATG systems.

PTS-2 controller SDK includes a PTS-2 controller and USB/RS-232 and USB/RS485 interface converters, which allow to run software simulators of fuel dispensers and ATG systems on personal computer and debug operation of control systems software with the PTS-2 controller on it without a necessity to connect to real fuel dispensers and ATG systems. Thus, it is convenient to work in office or at home rather than on a working petrol station being connected to real equipment.

PTS-2 controller SDK allows developers to:

1. Study operation with the PTS-2 controller.
2. Implement the PTS-2 controller into own developed POS system, OPT, server, mobile or desktop software application for control over fuel dispensers and ATG level measurement systems for petrol stations.
3. Debug own software application to correctly provide control over various popular fuel dispensers locally (on the workplace) without a necessity to go to the petrol station and connect to real fuel dispensers and ATG probes using supplied with the PTS-2 controller SDK fuel dispensers and ATG probes software simulators.

PTS-2 controller SDK structure

HARDWARE:

1. PTS-2 controller over fuel dispensers and ATG systems for petrol stations: 1 pc
2. Interface converter RS-232/USB with cable: 1 pc
3. Interface converter RS-485/USB with cable: 1 pc
4. Cabling

SOFTWARE:

1. Software simulator of fuel dispensers
2. Software simulator of ATG systems (probes)
3. API for developers (with open-source applications in C++, C#, Java from Android, JavaScript languages)

Note: the RS-232/USB and RS-485/USB interface converters are based on FTDI chips, it is possible to download their drivers from the following page: <https://ftdichip.com/drivers/vcp-drivers/>.

PTS-2 controller SDK technical features

Specification

##	PARAMETER	VALUE
1	Voltage	12 V DC
2	Current consumption	850 mA max
3	Temperature range	-40°C ÷ +80°C
4	Weight	600 g
5	Overall dimensions	160 x 160 x 85 mm

PTS-2 controller SDK connections scheme

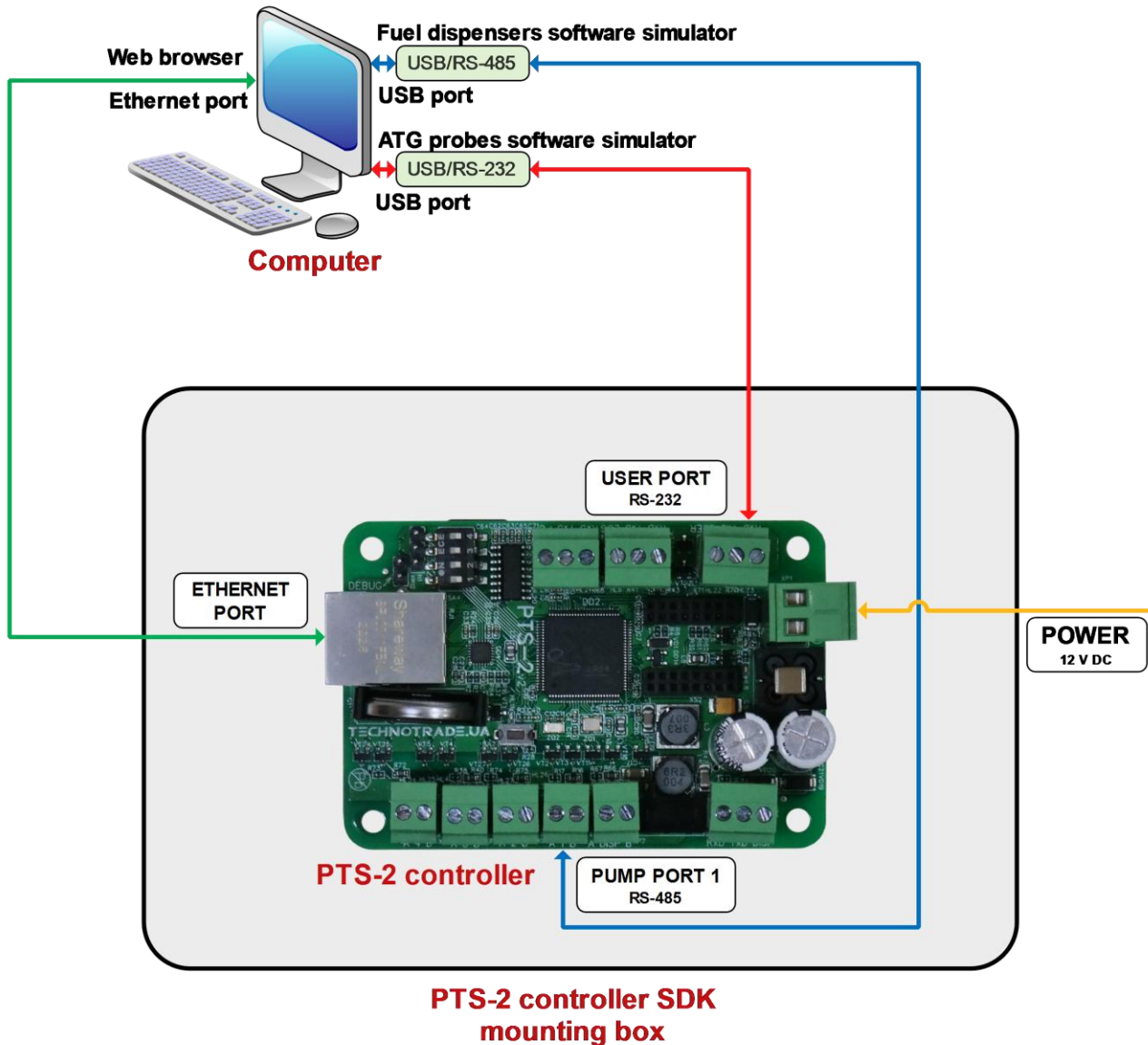

PTS-2 controller SDK box includes the PTS-2 controller board mounted inside of the metal mounting box, USB/RS-232 and USB/RS-485 interface converters and cabling with for communication.

Control systems, which use *jsonPTS communication protocol*, connects to Ethernet port of PTS-2 controller.

USB/RS-232 and USB/RS-485 interface converters are used in order to convert signals coming from PTS-2 controller pumps and probes ports to USB ports in computer in order to run the pumps and probes software simulators.

Thus, it is possible to debug a correct operation of software, being developed, with the PTS-2 controller without a necessity to connect to real fuel dispensers and ATG systems, but using fuel dispenser's software simulators and ATG system's software simulators.

UniPump pumps software simulator

Purpose

PTS-2 controller SDK includes a pumps software simulator with a purpose to enable debugging of PTS-2 controller implementation in third party software. Purpose of software simulators is to debug operation of control system software (cash register, POS system, OPT, etc) over fuel dispensers through PTS-2 controller without a necessity to connect to real fuel dispensers.

Main view

The screenshot shows the 'UniPump dispenser simulator' interface. At the top, a menu bar includes 'Port', 'View', and 'Simulation'. Below it, a 'COM' port is set to '8'. The main area is divided into eight panels, each representing a pump (Pump 1 to Pump 8). Each panel contains:

- Address:** A dropdown menu for the pump's physical address (e.g., Pump 1: address = 1).
- Amount, Volume, Price:** Digital displays for fuel metrics.
- Nozzle:** Radio buttons for nozzle selection (1-6).
- State:** Radio buttons for pump states: Preset, Authorization, End of transaction, Engine, and Reducing valve.
- Trigger:** Radio buttons for 'Off' and 'On'.
- Operation mode:** Radio buttons for 'Automatic' and 'Manual'.

At the bottom, a log window displays simulation data:

```

16:56:37 >>> [2] ExtendedStatusRequest
16:56:37 <<<< [2] ExtendedStatusResponse: nozzle = 2, status = 3

16:56:37 >>> [3] ExtendedStatusRequest
16:56:37 <<<< [3] ExtendedStatusResponse: nozzle = 0, status = 1
    
```

Callout boxes with red arrows point to specific features:

- Selection and opening/closing of a COM-port:** Points to the 'COM 8' dropdown.
- Pump physical address:** Points to the address dropdown for Pump 1.
- Simulation of presence:** Points to the 'Amount' display of Pump 1.
- Pump mode of operation:** Points to the 'Operation mode' (Automatic/Manual) for Pump 2.
- Volume and money total counters:** Points to the 'Volume' and 'Price' displays of Pump 3.
- Dispersed volume, money amount and price:** Points to the 'Amount', 'Volume', and 'Price' displays of Pump 3.
- Selection of nozzle to take up/down and its trigger state:** Points to the 'Nozzle' and 'Trigger' controls of Pump 4.
- State of pump:** Points to the 'State' controls of Pump 4.
- Log of simulator operation with specification of all transmitted commands and their data:** Points to the bottom log window.
- Pump mode of operation:** Points to the 'Operation mode' controls of Pump 6.

Pumps software simulator main view

In pumps simulator it is possible to add up to 99 pumps giving each a unique physical address. Each of the pumps leads separately its total counters (volume and money amount) and prices for each of its 6 nozzles. Total counter values as well as prices are stored in Windows system register. Each of the nozzles has a trigger.

Each of the pumps can be transferred to automatic mode of operation (controlled from the control system) or manual mode of operation (controlled manually and does not response to control system).



Pump control in pumps software simulator

In right-click mouse menu it is possible to preset the pump with money amount or volume value, stop the pump, reset, pause and change volume:

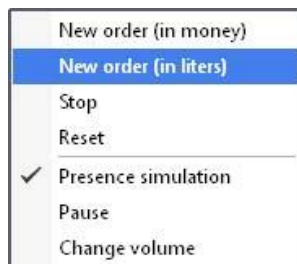

Pump right-button mouse menu

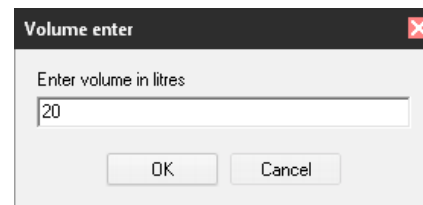

Volume preset menu for pump

Configuration

Configuration of the pumps simulator includes configuration of:

- communication settings, which include setting of baud rate, number of data bits and stop bits, parity control
- quantity of pumps (physical address is set on each pump control independently)
- technical characteristics of the pumps in simulator (flow rate, slow flow rate (when slowflow valve is on), quantity of pulses before the slowflow valve is switched on)
- protocol type: selection between standard UniPump communication protocol and extended UniPump communication protocol for PTS-2 controller
- setting quantity of digits in values of volume, money amount, price and total counters
- selection of graphical skin

Pumps simulator can simulate presence at the pumps – take up nozzles and make dispensing in random way thus making it possible to debug control system software as if it was operating on real petrol station.

Log window of the pumps simulator enables to see all the requests and responses in communication and their respective data.

The screenshot shows a 'Settings' dialog box with the following sections:

- Communication settings:** Baud rate is set to 9600, Bits to 8, Stop bits to 1, and Parity to none.
- Protocol type:** The 'Extended UniPump for PTS controller' option is selected.
- Pumps settings:** Pumps quantity is 8, Flow rate (l/s) is 40, Slow flow rate (l/s) is 10, Pulses quantity before slow flow rate is 50, and Skin is set to GPlus.
- Settings of quantity of decimal digits:** Quantity of decimal digits in money amount is 2, in volume is 3, in price is 2, in money amount total counters is 2, and in volume total counters is 3.

Buttons for 'OK' and 'Cancel' are located at the bottom right of the dialog.

Settings of pumps simulator

For communication of the PTS-2 controller with the UniPump pumps software simulator it is necessary to select in the PTS-2 controller configuration of the pump port communication protocol "2. UniPump" and select appropriate baud rate (equal to set in simulator (9600 baud rate by defaults) and set pumps physical addresses equal to those, which are set for pumps in simulator.

UniProbe ATG probes software simulator

Purpose

PTS- controller SDK includes a ATG probes software simulator with a purpose to enable debugging of PTS-2 controller implementation in third party software. Purpose of software simulators is to debug operation of control system software (cash register, POS system, OPT, etc) over ATG systems through PTS-2 controller without a necessity to connect to real ATG systems or probes.

Main view

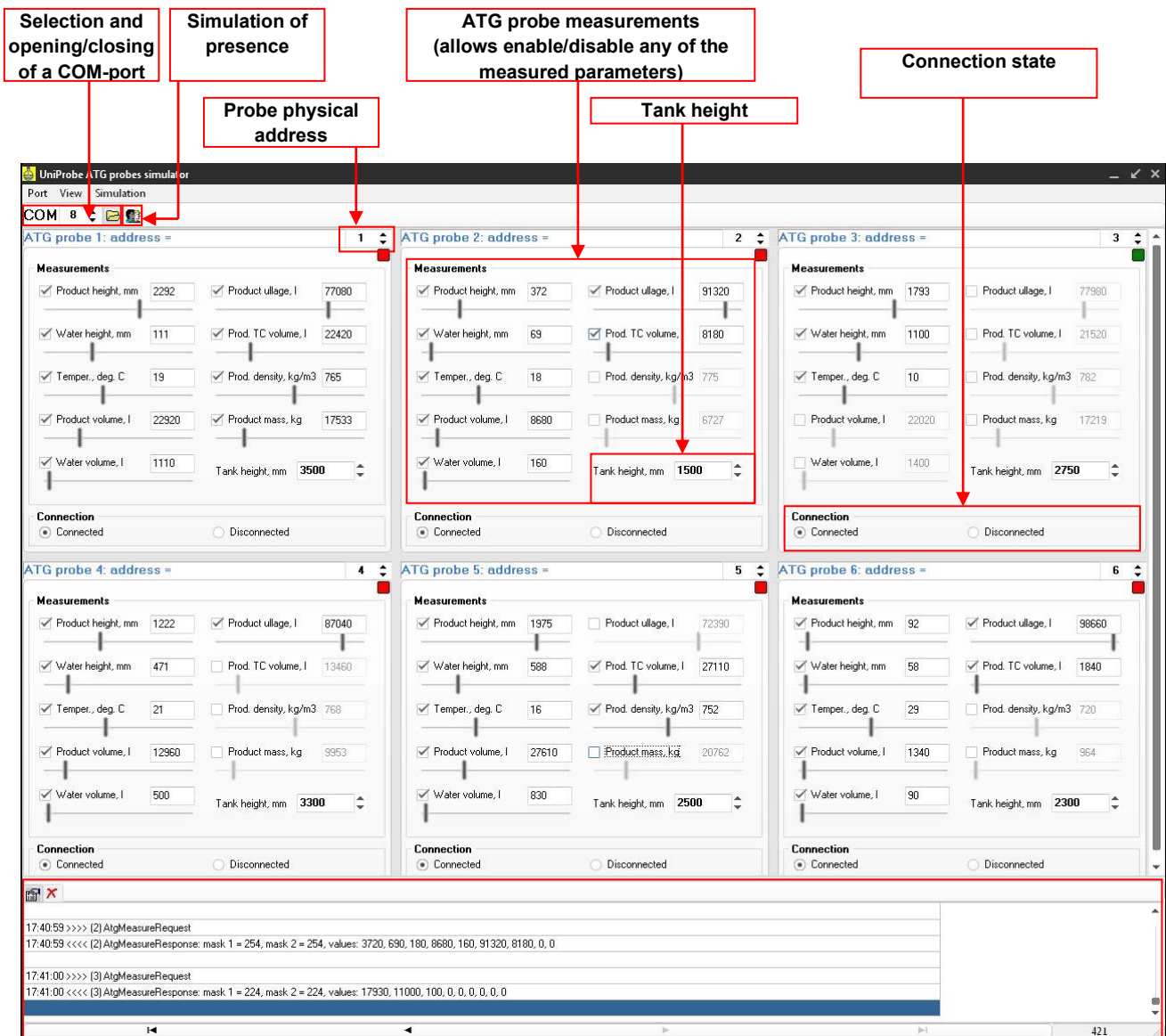

Log of simulator operation with specification of all transmitted commands and their data

ATG probes software simulator main view

In ATG probes simulator it is possible to set measurements of the following parameters:

- product height
- water height
- temperature
- product volume

- water volume
- product ullage
- product temperature compensated volume
- product density
- product mass

Any of the specified parameters can be switched on or off.

Also, it is possible to set height of tank in the system.

Each of the ATG probes can be transferred to connected (responses to PTS-2 controller) or disconnected (does not response to PTS-2 controller) state.

Probe control in ATG probes software simulator

Configuration

Configuration of the pumps simulator includes configuration of:

- communication settings, which include setting of baud rate, number of data bits and stop bits, parity control
- quantity of ATG probes (physical address is set on each probe control independently)
- selection of graphical skin

Settings of probes simulator

Probes simulator can simulate presence of liquids in tanks – change height and volume of fuel, temperature mass in random way thus making it possible to debug control system software as if it was operating on real petrol station.

Log window of the probes simulator enables to see all the requests and responses in communication and their respective data.

For communication of the PTS-2 controller with UniProbe ATG probes software simulator it is necessary to select in the PTS-2 controller configuration of the probe port communication protocol “9. UniProbe” and select appropriate baud rate (equal to set in simulator (9600 baud rate by defaults) and set probes physical addresses equal to those, which are set for probes in simulator.

.NET Core API and open-source application

PTS-2 controller SDK includes .NET Core API library and an open-source application compatible with various operating systems (Windows, Linux, MacOS) with different processor architectures. Communication with PTS-2 controller is made using commands and responses described in jsonPTS communication protocol (own proprietary protocol of Technotrade LLC) – see document “*jsonPTS communication protocol specification for PTS-2 controller*” for more information. Developers can use it in their projects without any limitation.

Pump	Status	Nozzle	Price	Filled Volume	Filled Amount	Total Volume	Total Amount	User	Request
1	NOZZLE	1	1.11	14.29	15.86	0.00	0.00		
2	IDLE	0	1.05	11.36	11.93	0.00	0.00		
3	FILLING	2	1.05	8.20	8.61	0.00	0.00	admin	
4	NOZZLE	1	1.05	5.95	6.25	0.00	0.00		

Nozzle	Fuel	Price
<input type="radio"/> 1	Petrol	1,11
<input checked="" type="radio"/> 2	Diesel	1,05
<input type="radio"/> 3	LPG	1,45
<input type="radio"/> 4		0.00
<input type="radio"/> 5		0.00
<input type="radio"/> 6		0.00

Step-by-step configuration of the PTS-2 controller SDK

Purpose

This step-by-step instruction is provided in order to simplify understanding of PTS-2 controller SDK operation and assembling. It describes basic steps to be made with the PTS-2 controller SDK to assemble it correctly and also to install and configure software coming in its structure.

Step 1. Assembling PTS-2 controller SDK cabling and connection to computer

For connection of the PTS-2 controller SDK cabling it is necessary to have 2 USB-ports available in computer:

- one USB-port – for fuel dispenser software simulator
- second USB-port – for ATG probe software simulator

In case of absence of free USB-port it is possible to extend their number using a USB hub.

PTS-2 controller SDK is generally supplied in a mounting box, in which the PTS-2 controller is located and cables are connected with USB/RS-485 and USB/RS-232 interface converters. In order to start operation, it is necessary to connect the PTS-2 controller Ethernet port to computer and also to plug the USB output of the cables to USB ports of computer, after that power on the PTS-2 controller SDK.

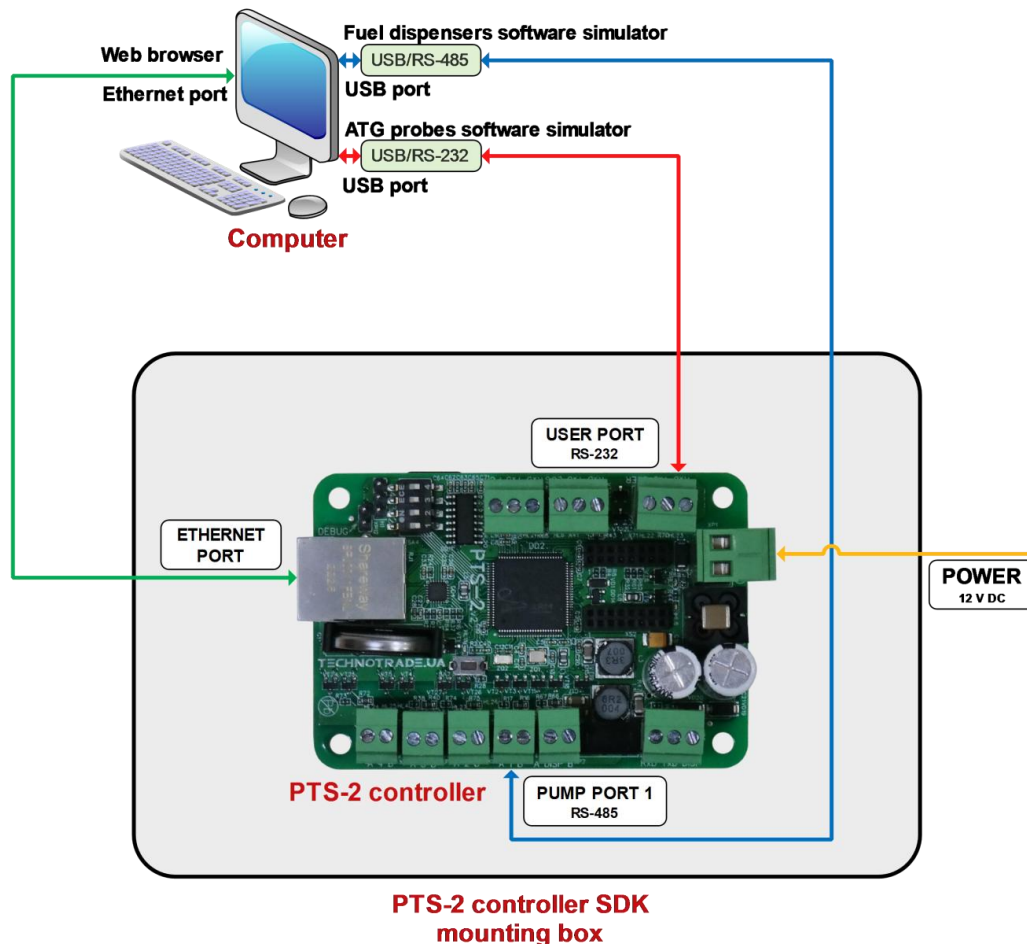

1. Connection of computer with PTS-2 controller: connect cable coming from Ethernet port of the PTS-2 controller to Ethernet port of computer.

2. Connection of pumps software simulator: connect cable coming from *PUMP PORT 1* of the PTS-2 controller to USB port of computer through USB/RS-485 interface converter (it will be seen as COM-port in the computer).
3. Connection of probes software simulator: connect cable coming from *USER PORT* of the PTS-2 controller to USB port of computer through USB/RS-232 interface converter (it will be seen as COM-port in the computer).
4. Switch on (power on) the PTS-2 controller SDK (requires 12 V DC power supply source).

It is worth to mention that only 1 application can work with a specific COM-port at the time, 2 applications can not share the same COM-port.

Note: the RS-232/USB and RS-485/USB interface converters are based on FTDI chips, it is possible to download their drivers from the following page: <https://ftdichip.com/drivers/vcp-drivers/>.

Step 2. Starting of PTS-2 controller web-server

Follow instructions of the section [Connection to web-server](#).

Step 3. Configuration of pump ports

Go to [Configuration](#) page to [Pumps](#) tab and set pumps ports configuration as shown on below screenshot. Set protocol "2. UniPump" for pump port 1 and baud rate "4. 9600". Assign this pump port to pumps 1 - 4, set the physical addresses of these pumps also 1 – 4.

Click the button *Set* to save configuration in PTS-2 controller.

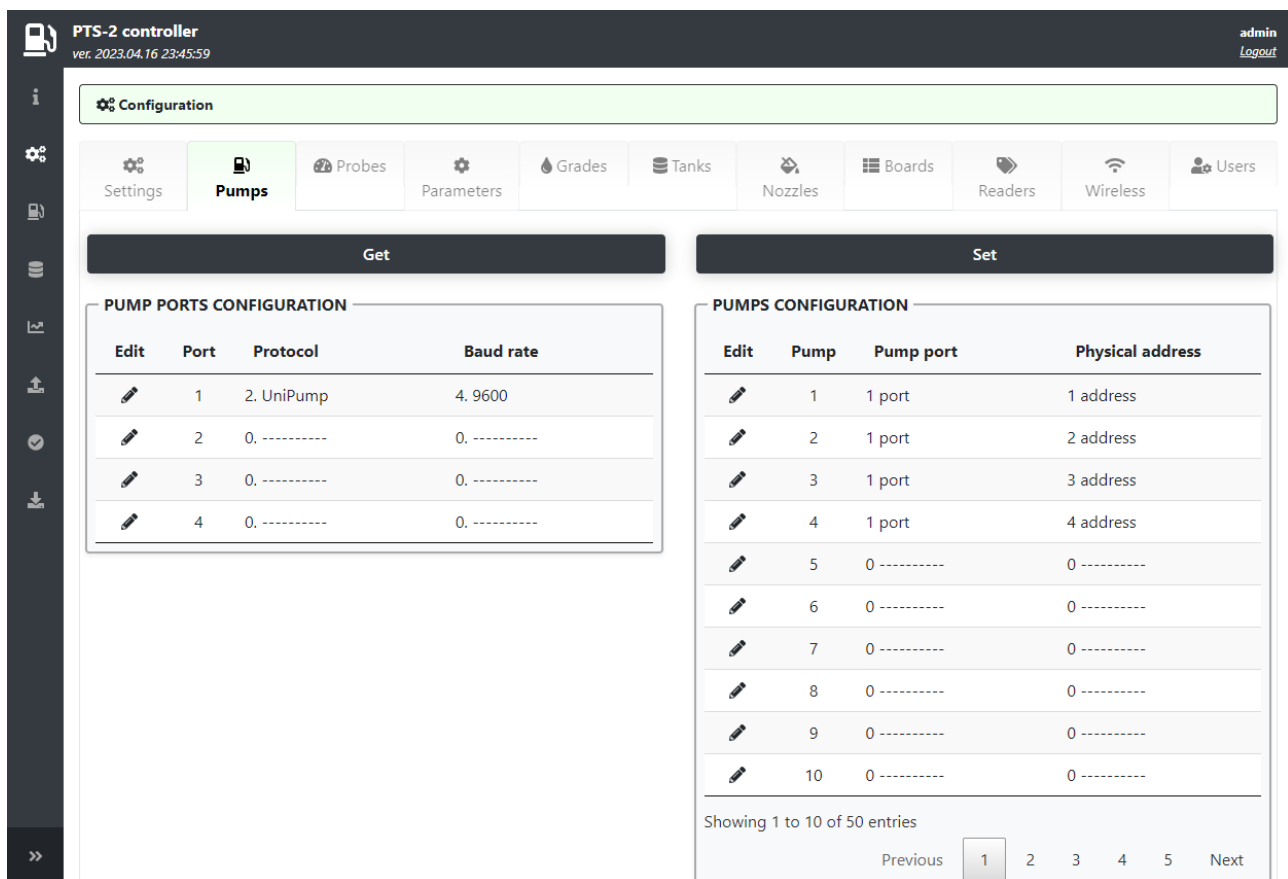

The screenshot displays the 'PTS-2 controller' web interface. The top navigation bar includes 'admin' and 'Logout'. The main menu has 'Configuration' selected, with sub-tabs for Settings, Pumps, Probes, Parameters, Grades, Tanks, Nozzles, Boards, Readers, Wireless, and Users. The 'Pumps' tab is active, showing two configuration tables.

Get - PUMP PORTS CONFIGURATION

Edit	Port	Protocol	Baud rate
	1	2. UniPump	4. 9600
	2	0.	0.
	3	0.	0.
	4	0.	0.

Set - PUMPS CONFIGURATION

Edit	Pump	Pump port	Physical address
	1	1 port	1 address
	2	1 port	2 address
	3	1 port	3 address
	4	1 port	4 address
	5	0.	0.
	6	0.	0.
	7	0.	0.
	8	0.	0.
	9	0.	0.
	10	0.	0.

Showing 1 to 10 of 50 entries

Previous 2 3 4 5 Next

Step 4. Configuration of probes ports

Go to [Configuration](#) page to [Probes](#) tab and set probes ports configuration as shown on below screenshot. Set protocol "9. UniProbe" for probe port USER and baud rate "4. 9600". Assign this probe port to probes 1 - 3, set the physical addresses of these probes also 1 – 3.

Click the button *Set* to save configuration in PTS-2 controller.

The screenshot shows the 'PTS-2 controller' web interface. The top navigation bar includes 'Settings', 'Pumps', 'Probes', 'Parameters', 'Grades', 'Tanks', 'Nozzles', 'Boards', 'Readers', 'Wireless', and 'Users'. The 'Probes' tab is selected. Below the navigation bar, there are two main sections: 'Get' and 'Set'.

The 'Get' section displays the 'PROBE PORTS CONFIGURATION' table:

Edit	Port	Protocol	Baud rate
	DISP	0. -----	0. -----
	LOG	0. -----	0. -----
	USER	9. UniProbe	4. 9600

The 'Set' section displays the 'PROBES CONFIGURATION' table:

Edit	Probe	Probe port	Physical address
	1	USER	1
	2	USER	2
	3	USER	3
	4	0 -----	0
	5	0 -----	0
	6	0 -----	0
	7	0 -----	0
	8	0 -----	0
	9	0 -----	0
	10	0 -----	0

At the bottom of the 'Set' section, there is a pagination control showing 'Showing 1 to 10 of 50 entries' and a set of buttons: 'Previous', '1', '2', '3', '4', '5', 'Next'.

Step 5. Configuration of PTS-2 controller parameters

Go to [Configuration](#) page [Parameters](#) tab and select from a device list item *Controller*, click on a button *Set default*.

The screenshot shows the web interface for the PTS-2 controller. The top header displays 'PTS-2 controller' with version '2023.04.16 23:45:59' and a user 'admin' with a 'Logout' link. A navigation sidebar is on the left. The main content area has a 'Configuration' header and a menu with tabs: Settings, Pumps, Probes, Parameters (selected), Grades, Tanks, Nozzles, Boards, Readers, Wireless, and Users. Below the menu are three buttons: 'Get', 'Set', and 'Set default'. A 'Device' dropdown menu is set to 'Controller'. The main content is a table with columns 'Description', 'Default', and 'Value'.

Description	Default	Value
1. GENERAL SETTINGS		
1.1. GUI language Sets languages used for graphical user interface of web-server.	English	English
1.2. Volume measurement units Sets measurement units used in system for volume.	Liters	Liters
1.3. Temperature measurement units Sets measurement units used in system for temperature.	Degrees Celcius	Degrees Celcius
1.4. Base temperature for product temperature-compensated volume Sets the base temperature for calculation of temperature-compensated volume of product in tank based on present volume, temperature and fuel grade temperature expansion coefficient.	15 degrees Celcius	15 degrees Celcius
1.5. Stop pumps on power failure Sets whether stop command should be automatically sent to pumps in case of controller power failure detection.	0	<input type="checkbox"/>
1.6. In the end of filling price on pump should be displayed equal to price of the used fuel grade Sets whether the price on the pump in the end of filling should be set to default price configured for used		

Step 6. Configuration of pumps parameters

On [Configuration](#) page [Parameters](#) tab select from a device list item *Pump*, in a field *Number* select pump 1, in a protocol list – “2. UniPump” (which means configuration of UniPump protocol parameters for pump 1).

Click on a button *Set default* to write default values. Change the parameter with index 1.2. “*Protocol type*” to value “*UniPump for PTS*” as it is shown on below screenshot.

Set current configuration for each of 4 pumps (select pumps one by one using field *Number*).

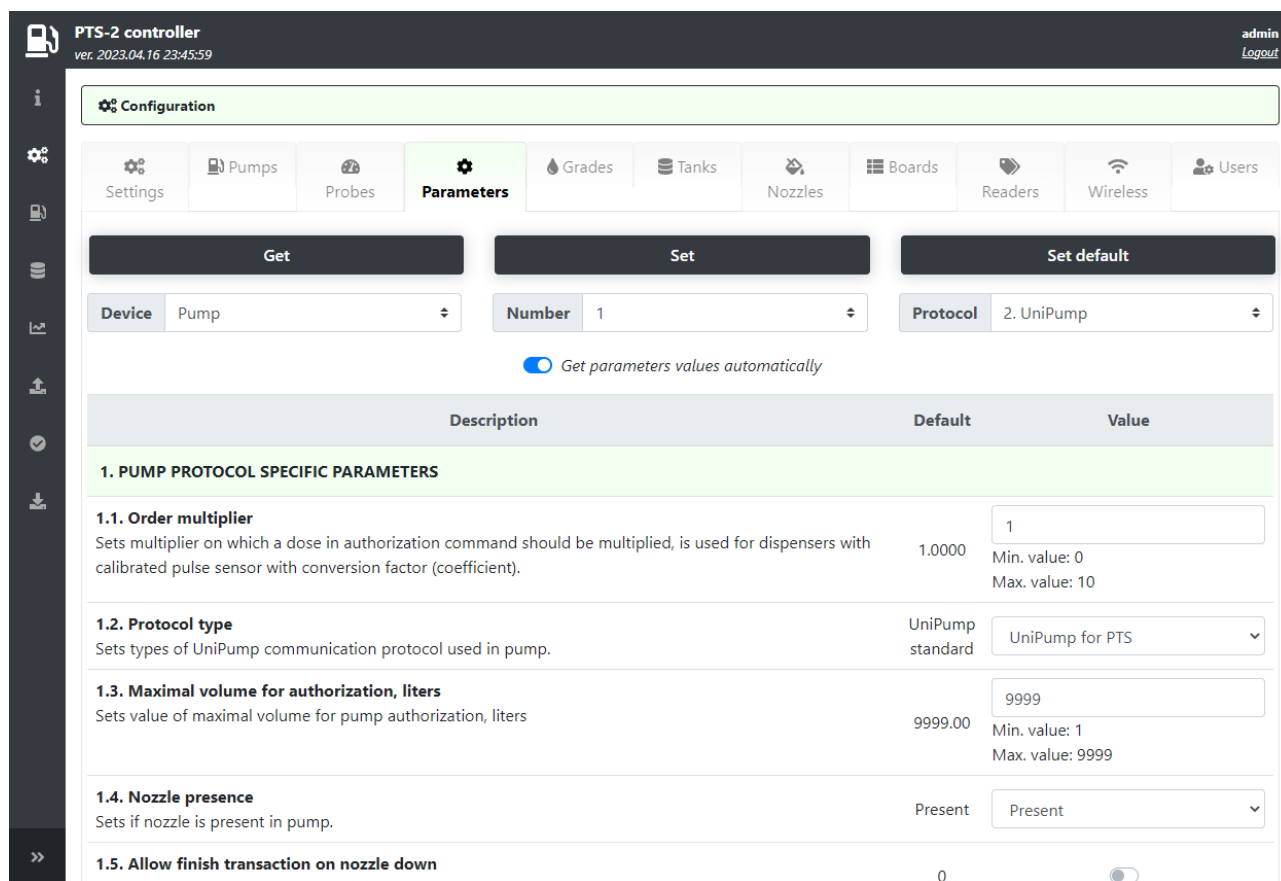

Step 7. Configuration of probe parameters

On [Configuration](#) page [Parameters](#) tab select from a device list item *Probe*, in a field *Number* select probe 1, in a protocol list – “2. UniProbe” (which means configuration of UniProbe protocol parameters for probe 1).

Click on a button *Set default* to write default values as it is shown on below screenshot.

Save current configuration for each of 4 probes (select probes one by one using field “*Number*”).

The screenshot shows the PTS-2 controller web interface. The top navigation bar includes 'Settings', 'Pumps', 'Probes', 'Parameters', 'Grades', 'Tanks', 'Nozzles', 'Boards', 'Readers', 'Wireless', and 'Users'. The 'Parameters' tab is active. Below the navigation bar, there are three buttons: 'Get', 'Set', and 'Set default'. The 'Set default' button is highlighted. Below these buttons, there are three dropdown menus: 'Device' (set to 'Probe'), 'Number' (set to '1'), and 'Protocol' (set to '9. UniProbe'). A toggle switch labeled 'Get parameters values automatically' is turned on. Below this, there is a table with columns 'Description', 'Default', and 'Value'.

Description	Default	Value
1. PROBE GENERAL SETTINGS		
1.1. Probe offset from tank bottom, mm Sets offset between probe bottom edge and tank's bottom in millimeters, this setting is used for automatic calculation of product and water volume based on tanks' calibration charts.	0	<input type="text" value="0"/>
1.2. Negative probe offset from tank bottom, mm Sets negative value for offset between probe bottom edge and tank's bottom.	0	<input type="checkbox"/>
1.3. Probe water float minimal level, mm Sets minimal water level, which can be detected by the probe in millimeters. For lesser water level the controller will provide 0 for water level. This parameter is needed for some magnetostrictive probes, in which due to the construction of the water float in the bottom of the probe informs some water level value even if there is no water present.	0	<input type="text" value="0"/>
1.4. Automatic calculation of product volume Sets to enable automatic calculation of product volume in tanks based on tanks' calibration charts. This option needs tanks to have calibration charts configured in controller.	0	<input type="checkbox"/>

Step 8. Configuration of fuel grades

On *Configuration* page *Fuel grades* tab configure fuel grades used in pumps. Click *Set* button to save the changes.

PTS-2 controller
ver. 2023.04.16 23:45:59

admin
Logout

Configuration

Settings Pumps Probes Parameters **Grades** Tanks Nozzles Boards Readers Wireless Users

Get Set

Edit	No.	Name	Price	Temperature expansion coefficient	Blended tank 1	Blend percentage	Blended tank 2
	1	Petrol	1.11	0.0011	0	0	0
	2	Diesel	1.05	0.00082	0	0	0
	3	LPG	1.45	0.00245	0	0	0
	4		0	0.00000	0	0	0
	5		0	0.00000	0	0	0
	6		0	0.00000	0	0	0
	7		0	0.00000	0	0	0
	8		0	0.00000	0	0	0
	9		0	0.00000	0	0	0
	10		0	0.00000	0	0	0

Showing 1 to 10 of 20 entries

Previous 1 2 Next

Step 9. Configuration of tanks

On *Configuration* page *Tanks* tab configure tanks fuel grades and height. Click *Set* button to save the changes.

PTS-2 controller
ver. 2023.04.16 23:45:59
admin
Logout

Configuration

Settings

Pumps

Probes

Parameters

Grades

Tanks

Nozzles

Boards

Readers

Wireless

Users

Get
Set

Edit	Tank	Fuel grade	Height, mm	Critical high product alarm, mm	High product alarm, mm	Low product alarm, mm	Critical low product alarm, mm	High water alarm, mm	Stop pumps at reaching the critical low product height
	1	Grade 1 (Petrol, price: 1.11)	3750	0	3500	300	0	0	No
	2	Grade 2 (Diesel, price: 1.05)	3250	0	3150	300	0	0	No
	3	Grade 3 (LPG, price: 1.45)	2750	0	2500	200	0	0	No
	4	0	0	0	0	0	0	0	No
	5	0	0	0	0	0	0	0	No
	6	0	0	0	0	0	0	0	No
	7	0	0	0	0	0	0	0	No
	8	0	0	0	0	0	0	0	No

Step 10. Configuration of pump nozzles

On *Configuration* page *Pump nozzles* tab configure nozzles for each pump. Click *Set* button to save the changes.

The screenshot shows the 'PTS-2 controller' interface with the 'Configuration' section active. The 'Nozzles' tab is selected, displaying a table for configuring pump nozzles. The table has columns for 'Edit', 'Pump', and pairs of 'Grade noz.' and 'Tank noz.' for grades 1 through 6. Each row represents a pump (1-4) and shows the current configuration (e.g., Grade 1: Petrol, price: 1.11; Tank 1: Petrol) and a 'Set' button to save changes.

Get		Set											
Edit	Pump	Grade noz. 1	Tank noz. 1	Grade noz. 2	Tank noz. 2	Grade noz. 3	Tank noz. 3	Grade noz. 4	Tank noz. 4	Grade noz. 5	Tank noz. 5	Grade noz. 6	Tank noz. 6
	1	Grade 1 (Petrol, price: 1.11)	Tank 1 (Petrol)	Grade 2 (Diesel, price: 1.05)	Tank 2 (Diesel)	Grade 3 (LPG, price: 1.45)	Tank 3 (LPG)	0	0	0	0	0	0
	2	Grade 1 (Petrol, price: 1.11)	Tank 1 (Petrol)	Grade 2 (Diesel, price: 1.05)	Tank 2 (Diesel)	Grade 3 (LPG, price: 1.45)	Tank 3 (LPG)	0	0	0	0	0	0
	3	Grade 1 (Petrol, price: 1.11)	Tank 1 (Petrol)	Grade 2 (Diesel, price: 1.05)	Tank 2 (Diesel)	Grade 3 (LPG, price: 1.45)	Tank 3 (LPG)	0	0	0	0	0	0
	4	Grade 1 (Petrol, price: 1.11)	Tank 1 (Petrol)	Grade 2 (Diesel, price: 1.05)	Tank 2 (Diesel)	Grade 3 (LPG, price: 1.45)	Tank 3 (LPG)	0	0	0	0	0	0

PTS-2 controller developed by Technotrade LLC

Step 11. Configuration of pumps software simulator

Run *SimUniPump.exe* and go to configuration of its properties. Set properties as shown on screenshot:

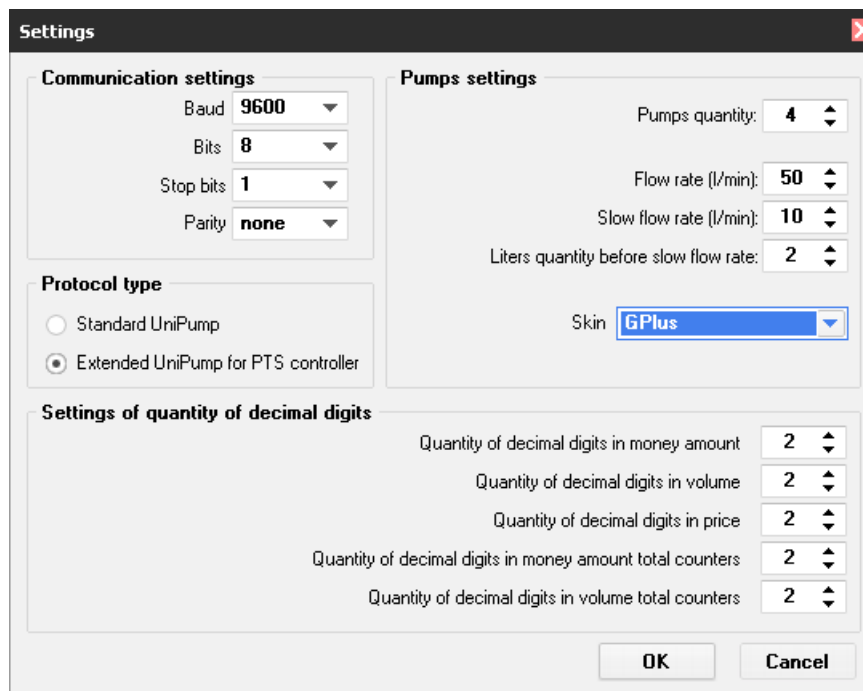

After properties are set click OK and on the main form select a COM-port, to which pump port is connected, and click “Open” button:

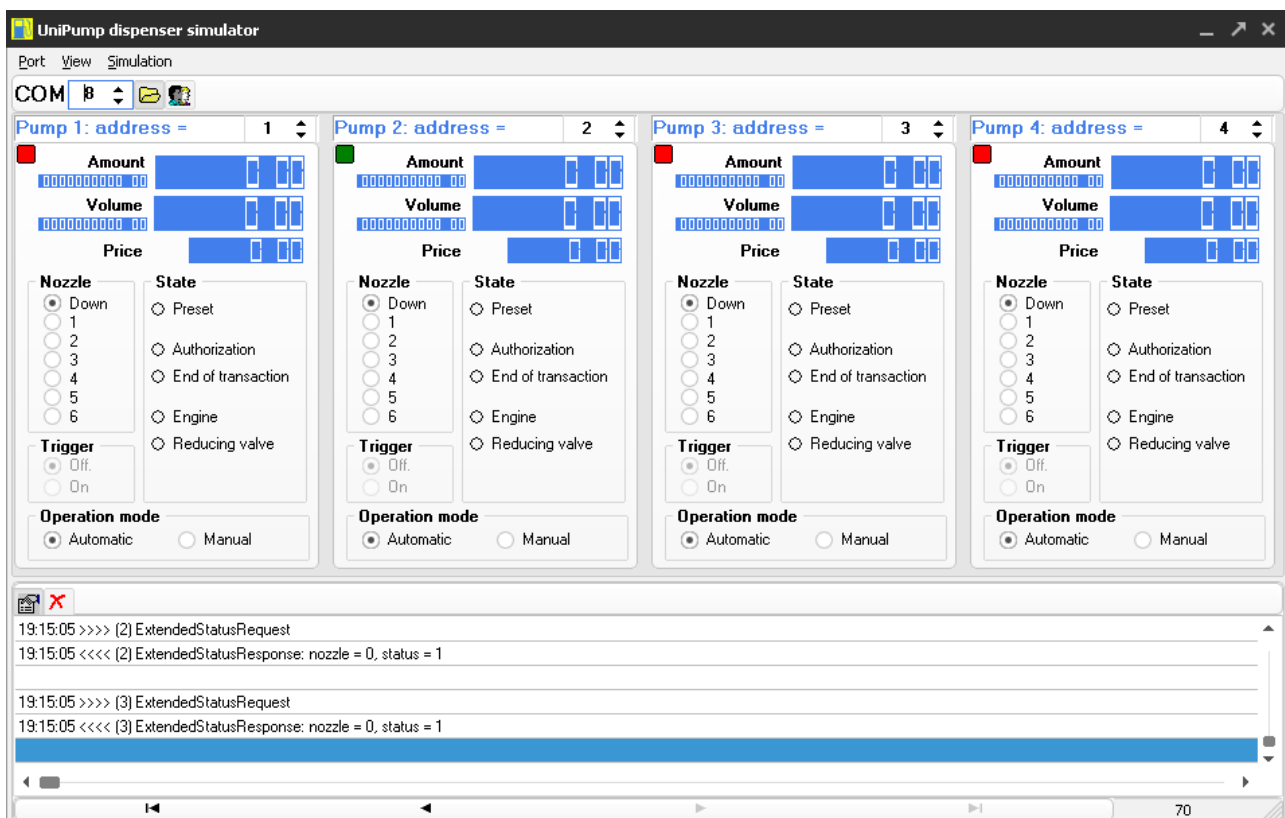

After COM-port is opened in case if there is communication between the PTS-2 controller and pump simulator – you should see blinking of red squares located in left top corner of pump icons in pump simulator, and communication will be logged in log window of the simulator.

At this in PTS-2 controller on pump port 1 green and red LEDs will begin to blink. Blinking of the green LED means that PTS-2 controller is sending requests to the pump, blinking of the red LED means that the PTS-2 controller receives responses from the pump.

In case if only green LED is blinking on pump port 1 – there is a mistake in wiring connection or configuration of the equipment (PTS-2 controller or pump).

Step 12. Configuration of ATG probes software simulator

Run *SimUniProbe.exe* and go to configuration of its properties. Set properties as shown on screenshot:

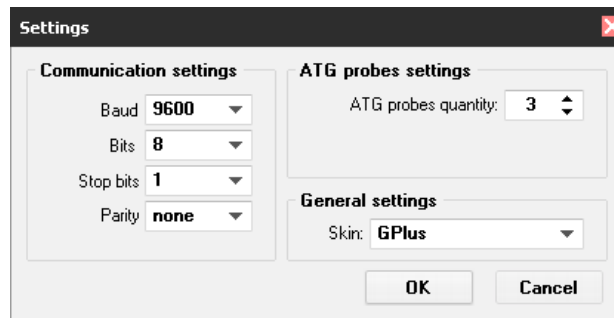

After properties are set click OK and on the main form select a COM-port, to which USER port of PTS-2 controller is connected, and click “Open” button.

After COM-port is opened in case if there is communication between the PTS-2 controller and ATG probes simulator – you should see blinking of red squares located in left top corner of ATG probes icons in ATG probes simulator, and communication will be logged in log window of the simulator.

At this in PTS-2 controller on USER port green and red LEDs will begin to blink once per second. Blinking of the green LED means that PTS-2 controller is sending requests to the ATG, blinking of the red LED means that the PTS-2 controller receives responses from the ATG.

In case if only green LED is blinking on USER port – there is a mistake in wiring connection or configuration of the equipment (PTS-2 controller or ATG).

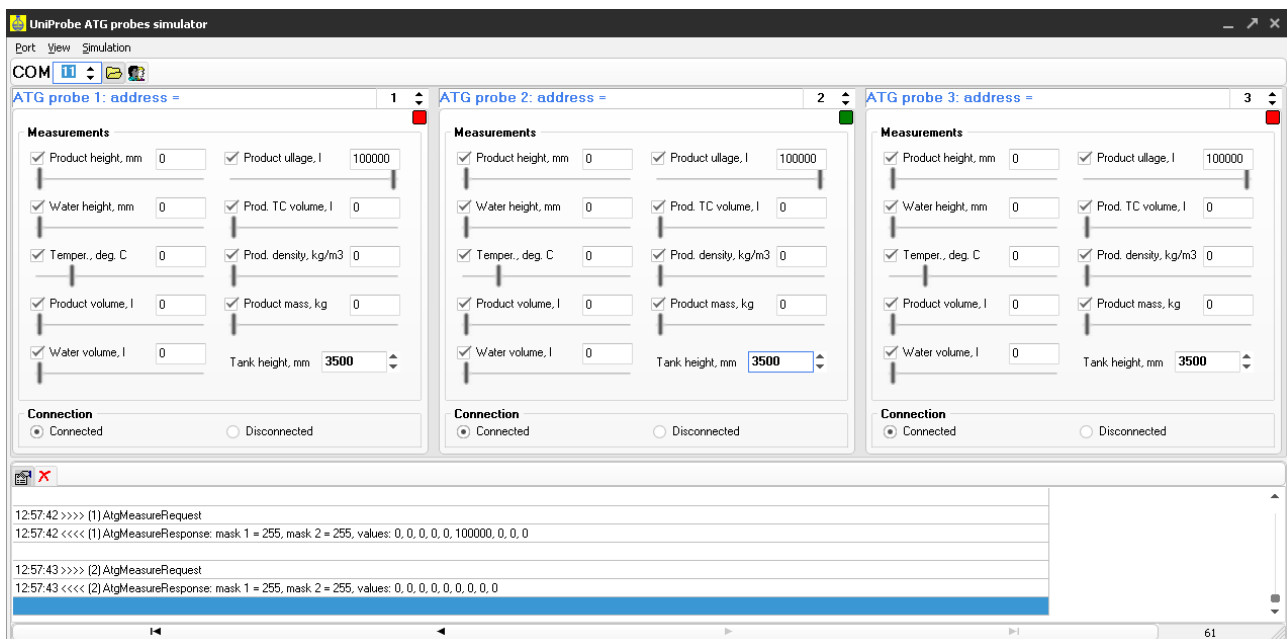

Step 13. Control over pumps and ATG probes

Go to *Pumps control* page in web-browser, you should see all the pumps.

Set initial values in the pump simulator to display them in the web-browser. Take up nozzles on some pumps. In the web-browser you will see these changes. Now you are able to provide full control over the pumps:

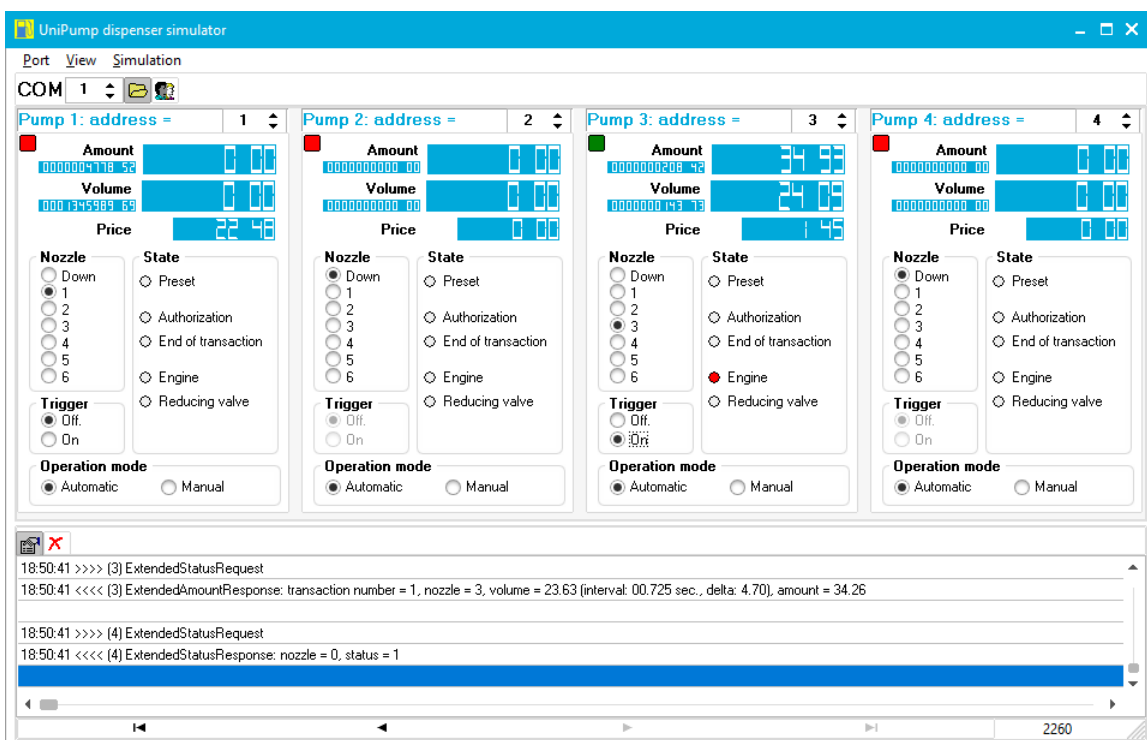
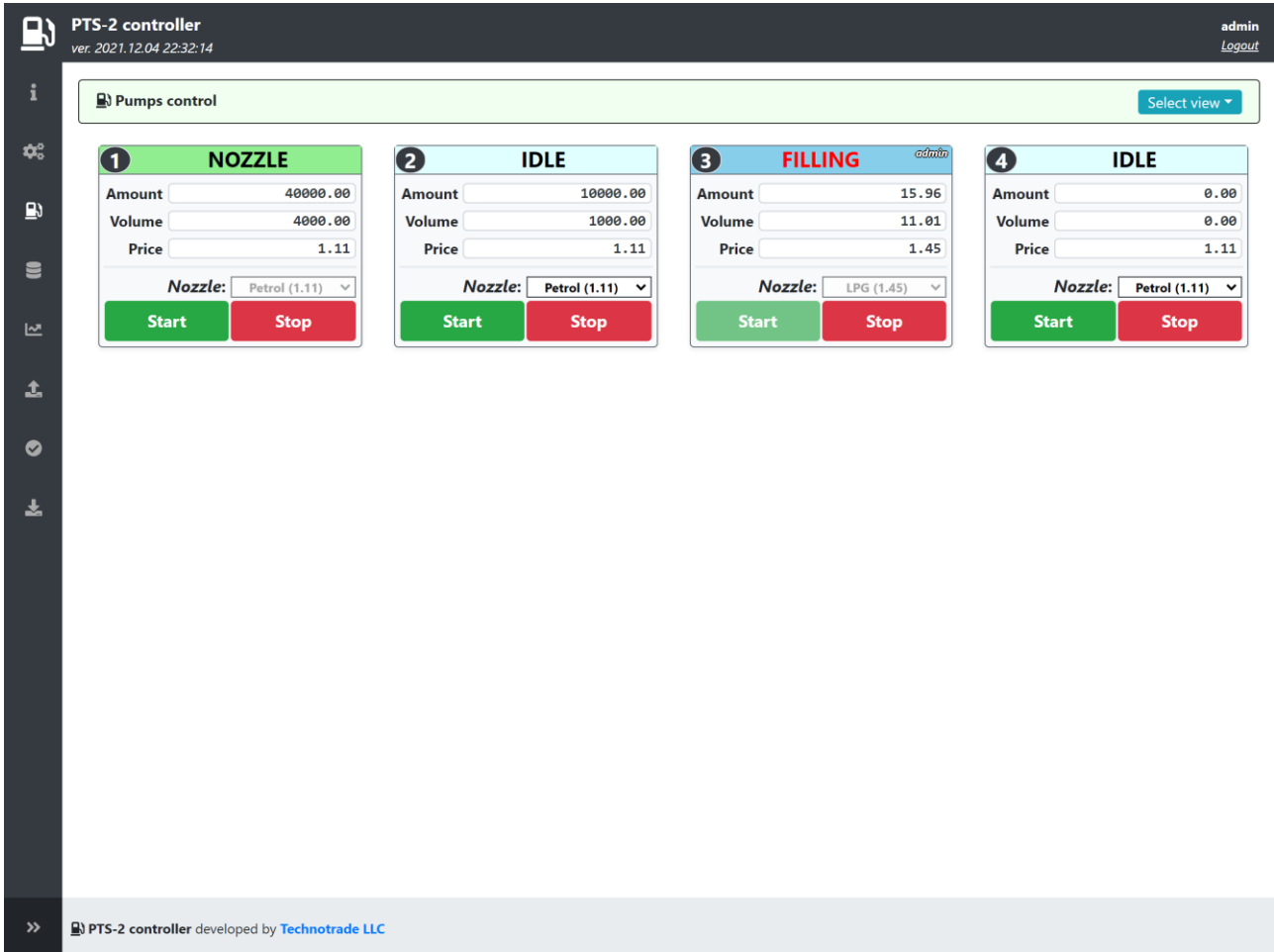

Go to Tanks monitoring page in web-browser, you should see all the tanks.

Set initial values in the ATG probes simulator to display them in the web-browser. Set values for the ATG probes (there is a possibility to emulate presence in the simulator to make them work if there was really process going on). In the web-browser you should see these changes. Now you are able to receive data from the ATG probes:

The screenshot shows the 'Tanks monitoring' page of the PTS-2 controller. It displays three tanks: 1. Petrol (27%), 2. Diesel (29%), and 3. LPG (21%). Each tank card lists various parameters such as Product height, Product volume, Product TC volume, Product ullage, Water height, Water volume, Temperature, Product density, and Product mass.

Tank	Product	Percentage	Product height (mm)	Product volume (L)	Product TC volume (L)	Product ullage (L)	Water height (mm)	Water volume (L)	Temperature (°C)	Product density (kg/m³)	Product mass (kg)
1	Petrol	27%	2675	26750	27250	73250	221	2210	29	737	19714
2	Diesel	29%	2938	29380	29880	70620	271	2710	26	756	22211
3	LPG	21%	2098	20980	21480	79020	115	1150	24	729	15294

Try to change the measured values of fuel in tanks and see how soon they are updated in web-browser.

The screenshot shows the 'UniProbe ATG probes simulator' interface. It displays three ATG probe configurations (1, 2, and 3) with various measurement parameters and connection status. Each probe has a 'Connection' section with 'Connected' and 'Disconnected' radio buttons.

Probe	Product height (mm)	Product ullage (L)	Water height (mm)	Prod. TC volume (L)	Temp. (deg. C)	Prod. density (kg/m³)	Product volume (L)	Product mass (kg)	Water volume (L)	Tank height (mm)
1	2675	73250	221	27250	29	737	26750	19714	2210	3500
2	2938	70620	271	29880	26	756	29380	22211	2710	3500
3	2098	79020	115	21480	24	729	20980	15294	1150	3500

At this stage we can provide control over pumps and monitor tanks, in web-browser we can open Web Developer Tools and see on tab Network the requests sent to PTS-2 controller and responses received.

Step 14. Saving of pumps sales and tank measurements to database with reports generation

Go to [Configuration](#) page and there to [Parameters](#) tab, select Device as PTS-2 controller and select checkboxes to save pumps sales to SD and also to save tanks measurements to SD as shown on screenshot below. Click Set button to save the changes.

The screenshot shows the configuration page for the PTS-2 controller. The page title is "PTS-2 controller" with a version number "ver. 2023.04.16 23:45:59" and a user "admin" with a "Logout" link. The main content area is titled "2. SD FLASH DISK SETTINGS". It contains several settings, each with a description, a value of "0", and a toggle switch. The settings are:

- 2.1. Save pumps sales to SD**: Sets whether all pumps sales should be saved to SD flash disk for reports generation. The toggle is turned on.
- 2.2. Save zero pump sales to SD**: When this parameter is activated - then zero and non-zero pump sales are saved to SD, when this parameter is not activated - then only non-zero pump sales are saved to SD. To save the pump sales a parameter "SAVE PUMPS SALES TO SD" should be enabled. The toggle is turned on.
- 2.3. Save tanks measurements to SD**: Sets whether all tanks measurements data should be saved to SD flash disk for reports generation. The toggle is turned on.
- 2.4. Save GPS data to SD**: Sets all GPS data should be saved to SD flash disk for reports generation. The toggle is turned off.
- 2.5. Save system alerts to SD**: Sets whether all system alerts should be saved to SD flash disk for reports generation. The toggle is turned off.
- 2.6. Keep SD flash disk operation at lower power**: Sets whether operation with SD flash disk should work in case of low power detection. The toggle is turned off.

Below these settings is a section titled "3. UNIPUMP PROTOCOL SETTINGS". It contains two settings:

- 3.1. Not use commands LockRequest and UnlockRequest**: Sets whether not to use commands LockRequest and UnlockRequest. If this option is disabled - then PTS may return responses UnlockStatusResponse or StatusResponse on request of StatusRequest (depending on the state of pump locking), otherwise PTS always returns StatusResponse on StatusRequest. The toggle is turned off.
- 3.2. Response only to configured pumps and probes numbers**: Sets whether controller should respond only to configured pumps and probes numbers and ignore requests to any other pumps and probes numbers. The toggle is turned off.

Now the PTS-2 controller will save all the pumps sales and tanks measurements to SD flash disk and it will allow us to view the saved records in reports.

Try to make same sales and change levels of products in tanks and review them in reports.

PTS-2 controller
ver. 2021.12.04 22:32:14
admin
[Logout](#)

Reporting

Pumps

Tanks

Pumps and tanks reconciliation

GPS

Report files

Pump All

Date/time start 12.12.21 18:55:55

Date/time end 13.12.21 18:55:55

Fuel grade All

User All

Tag All

Generate report

PUMPS TRANSACTIONS REPORT FOR ALL PUMPS FROM 12.12.21 18:55:55 TILL 13.12.21 18:55:55, DEVICE ID: 0041001C524E500420323442

Copy
Excel
CSV
Print

Show 10 entries
Search:

#	Date/time start	Date/time end	Pump	Nozzle	Transaction	Price	Filled volume, L	Filled amount	Volume totals, L	Amount totals
1	2021.12.13 18:55:09	2021.12.13 18:55:09	3	3 (LPG)	1	1.45	187.95	272.53	0.00	0.00
2	2021.12.13 18:55:19	2021.12.13 18:55:34	1	1 (Petrol)	5	1.11	8.95	9.93	0.00	0.00

PTS-2 controller
ver. 2021.12.04 22:32:14
admin
[Logout](#)

Reporting

Pumps

Tanks

Pumps and tanks reconciliation

GPS

Report files

Tank 1 (Petrol)

Date/time start 12.12.21 18:59:32

Date/time end 13.12.21 18:59:32

Direction All

Generate report

TANK LEVEL CHANGES REPORT FOR TANK 1 (PETROL) FROM 12.12.21 18:59:32 TILL 13.12.21 18:59:32, DEVICE ID: 0041001C524E500420323442

Copy
Excel
CSV
Print

Show 10 entries
Search:

#	Date/time	Direction	Product height, mm	Water height, mm	Temperature, °C	Product volume, L	Water volume, L	Product ullage, L	Product TC volume, L	Product density, kg/m ³
1	2021.12.13 18:56:47		2680	221	29	26750	2210	73250	27250	737
2	2021.12.13 18:57:22	↑	2902	221	29	29747	2210	73250	27250	737
3	2021.12.13 18:58:52		2902	221	29	29747	2210	73250	27250	737

Step 15. Reading of pump totals automatically in end of filling

Go to [Configuration](#) page and there to [Parameters](#) tab, select Device as pump and set for each pump a parameter to read pump totals automatically as shown on the image below. Click *Set* button to save the changes.

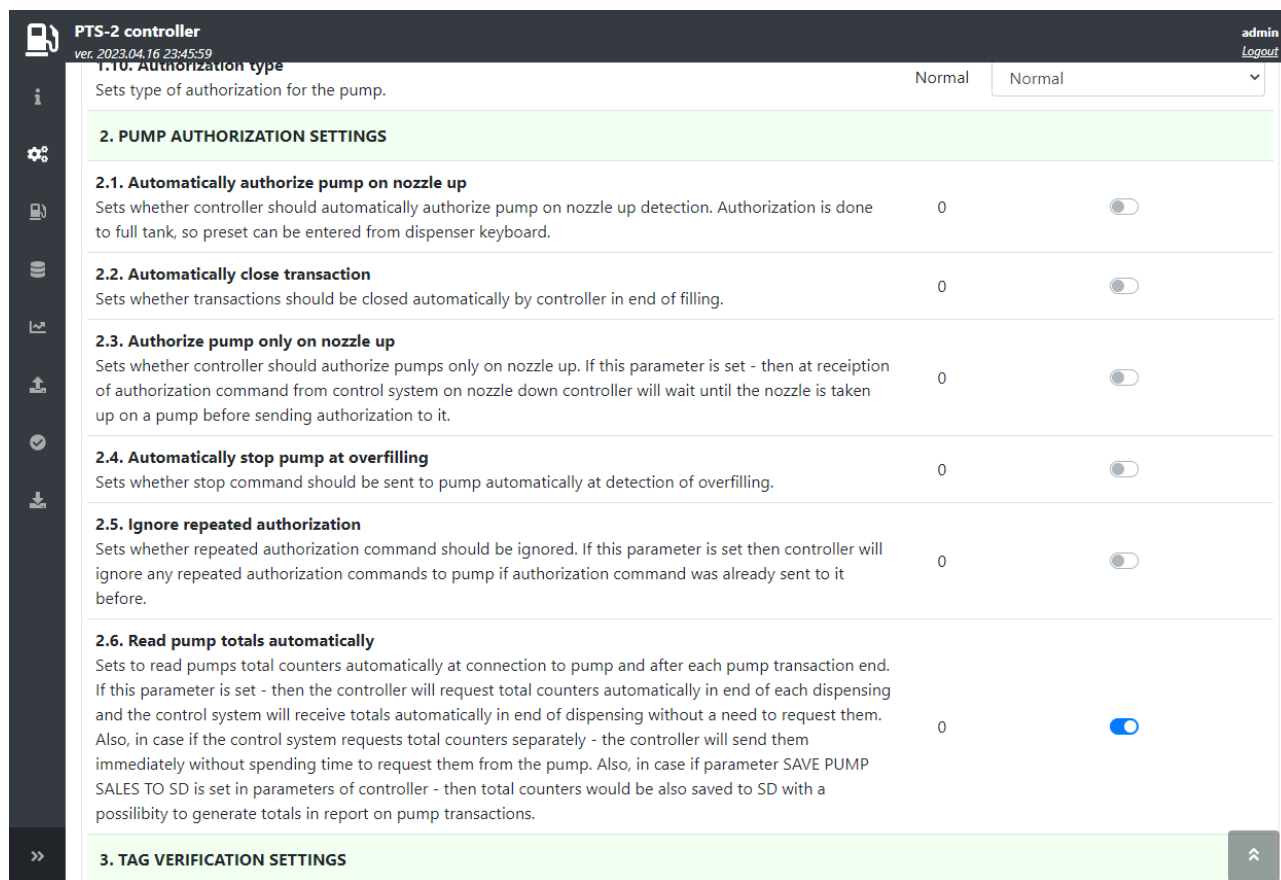

Now after these parameter is set PTS-2 controller should be reading totals automatically after each sale and save them to database. So, at generation of reports we should see the transactions reports together with totals.

The screenshot shows the 'PTS-2 controller' web interface. At the top, it displays 'admin' and 'Logout'. The main section is titled 'Pumps control' and contains a table with the following data:

Pump	Status	Nozzle	Price	Filled volume	Filled amount	Total volume	Total amount	User	Request
1	NOZZLE	1 (Petrol)	1.11	12.06	13.39	1346010.70	4801.84		
2	NOZZLE	2 (Diesel)	1.05	11.22	12.45	12.11	15.20		
3	NOZZLE	2 (Diesel)	1.05	9.01	9.46	12.42	13.04		
4	NOZZLE	3 (LPG)	1.45	8.28	12.00	8.28	12.01		

Below the table, there are controls for Pump 4: 'Pump 4', 'Preset type Full tank', and 'Preset dose 1.00'. A list of nozzles is shown with radio buttons, where 'Nozzle 3 LPG 1.45' is selected. To the right, there are several action buttons: 'Authorize', 'Stop', 'Resume', 'Suspend', and 'EMERGENCY STOP'. On the far right, there are buttons for 'Get prices', 'Set prices', 'Get total counters', 'Get tag ID', 'Turn lights on', and 'Turn lights off'. The footer indicates 'PTS-2 controller developed by Technotrade LLC'.

The screenshot shows the 'UniPump dispenser simulator' interface. It features four panels for Pump 1, Pump 2, Pump 3, and Pump 4. Each panel displays 'Amount', 'Volume', and 'Price' with digital readouts. Below each panel are controls for 'Nozzle' (Down, 1-6), 'State' (Preset, Authorization, End of transaction, Engine, Reducing valve), 'Trigger' (Off, On), and 'Operation mode' (Automatic, Manual). At the bottom, a log window shows the following messages:

```

19:03:23 <<<< (4) ExtendedStatusResponse: nozzle = 3, status = 3
19:03:23 >>>> (1) ExtendedStatusRequest
19:03:23 <<<< (1) ExtendedStatusResponse: nozzle = 1, status = 3
19:03:23 >>>> (2) ExtendedStatusRequest
    
```

PTS-2 controller
ver. 2021.12.04 22:32:14
admin
[Logout](#)

Reporting

Pumps

Tanks

Pumps and tanks reconciliation

GPS

Report files

Pump All

Date/time start 13.12.21 19:07:00

Date/time end 13.12.21 19:07:32

Fuel grade All

User All

Tag All

Generate report

PUMPS TRANSACTIONS REPORT FOR ALL PUMPS FROM 13.12.21 19:07:00 TILL 13.12.21 19:07:32, DEVICE ID: 0041001C524E500420323442

Copy Excel CSV Print

Search:

Show 10 entries

#	Date/time start	Date/time end	Pump	Nozzle	Transaction	Price	Filled volume, L	Filled amount	Volume totals, L	Amount totals
1	2021.12.13 19:07:12	2021.12.13 19:07:24	3	1 (Petrol)	5	1.11	7.14	7.93	110.08	757.30
2	2021.12.13 19:07:16	2021.12.13 19:07:25	4	2 (Diesel)	4	1.05	5.95	6.25	386.21	582.46

Step 16. Automatic pumps authorization on nozzle up

In order to make pumps work automatically as if in manual mode with saving of all sales to database we will additionally set checkboxes to automatically authorize pump on nozzle up and also to automatically close transaction in parameters for each pump as shown on screenshot below.

The screenshot displays the configuration page for the PTS-2 controller, titled "1.10. Authorization type". The page is divided into sections for authorization settings and tag verification settings. The "2. PUMP AUTHORIZATION SETTINGS" section contains six parameters, each with a description, a value of 0, and a toggle switch.

Parameter	Description	Value	Toggle
2.1. Automatically authorize pump on nozzle up	Sets whether controller should automatically authorize pump on nozzle up detection. Authorization is done to full tank, so preset can be entered from dispenser keyboard.	0	On
2.2. Automatically close transaction	Sets whether transactions should be closed automatically by controller in end of filling.	0	On
2.3. Authorize pump only on nozzle up	Sets whether controller should authorize pumps only on nozzle up. If this parameter is set - then at reception of authorization command from control system on nozzle down controller will wait until the nozzle is taken up on a pump before sending authorization to it.	0	Off
2.4. Automatically stop pump at overfilling	Sets whether stop command should be sent to pump automatically at detection of overfilling.	0	Off
2.5. Ignore repeated authorization	Sets whether repeated authorization command should be ignored. If this parameter is set then controller will ignore any repeated authorization commands to pump if authorization command was already sent to it before.	0	Off
2.6. Read pump totals automatically	Sets to read pumps total counters automatically at connection to pump and after each pump transaction end. If this parameter is set - then the controller will request total counters automatically in end of each dispensing and the control system will receive totals automatically in end of dispensing without a need to request them. Also, in case if the control system requests total counters separately - the controller will send them immediately without spending time to request them from the pump. Also, in case if parameter SAVE PUMP SALES TO SD is set in parameters of controller - then total counters would be also saved to SD with a possibility to generate totals in report on pump transactions.	0	On

The interface also shows a "3. TAG VERIFICATION SETTINGS" section at the bottom, which is currently collapsed. The top right corner of the interface shows the user "admin" and a "Logout" link.

Now, the pump automatically gets authorized by PTS-2 controller once a nozzle is taken up. At this each transaction is saved to SD flash disk and is seen in reports. The dispenser now works as in manual mode and preset can be entered from dispenser keyboard.

In this scheme we can additionally enable automatic upload of pumps sales to remote server to make operation of the dispensers be completely automatic with reception of reports in remote server.

Step 17. Testing of operation with PTS-2 controller from Postman utility

Postman utility provided by Postman, Inc (<https://www.postman.com/>) is a great tool to test communication with the PTS-2 controller. Please refer to document "*jsonPTS communication protocol specification for PTS-2 controller*" for information on how to configure Postman utility and use it for testing of communication with the PTS-2 controller.

EXAMPLES OF CONNECTION TO FUEL DISPENSERS

Below section shows examples of connection to various brands of fuel dispensers. This information is provided as an example. For obtaining of detailed information on connection to various brands of fuel dispensers, configuration of the fuel dispensers and configuration of PTS-2 controller please refer to our support page <https://www.technotrade.ua/support>.

As it is seen from below connection examples some brands of fuel dispensers have the RS-485 interface on board and are directly connected to the PTS-2 controller, others do not have the RS-485 interface and require some type of additional interface converter for connection to the PTS-2 controller. List of used interface converters can be found on a web-page <https://www.technotrade.ua/dispensers-interface-converters.html>.

In some cases, various models of same brand of fuel dispensers have the RS-485 interface, others – no. In such case the best way to check how your fuel dispenser is connected is to take its mainboard photos and send to us on our support mailbox support@technotrade.ua. Mainboard is normally located inside the fuel dispenser pumphead behind the displays.

Gilbarco dispenser connection scheme (2-wire current loop interface)

Connection to Gilbarco dispenser is normally made through 2-wire GB interface converter (<https://www.technotrade.ua/gilbarco-interface-converter.html>), which provides connection of RS-232/RS-485 interfaces to 2-wire current loop interface.

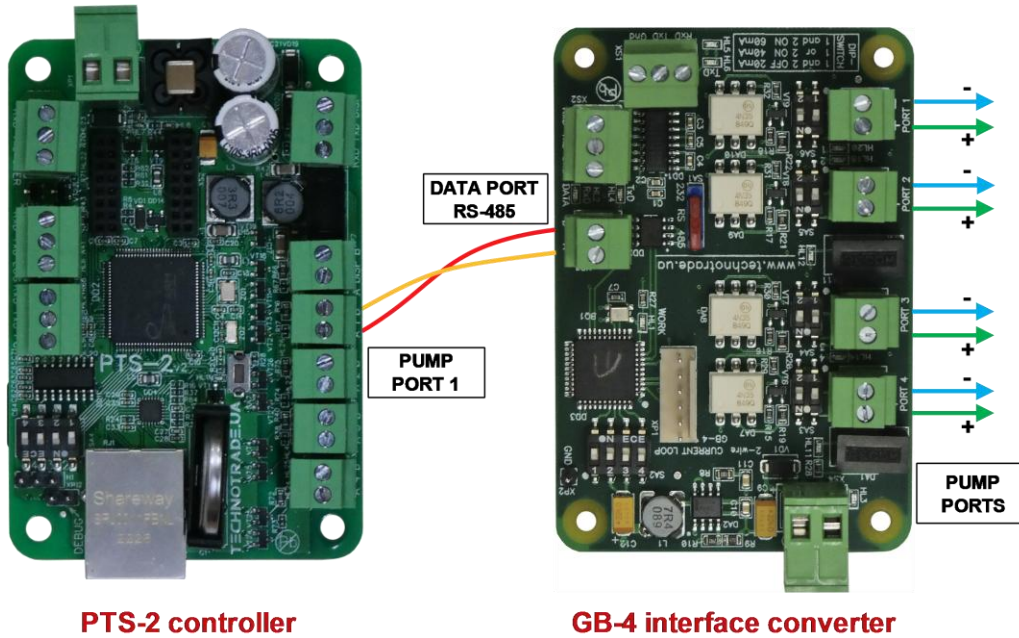

Gilbarco Encore 500 dispenser board

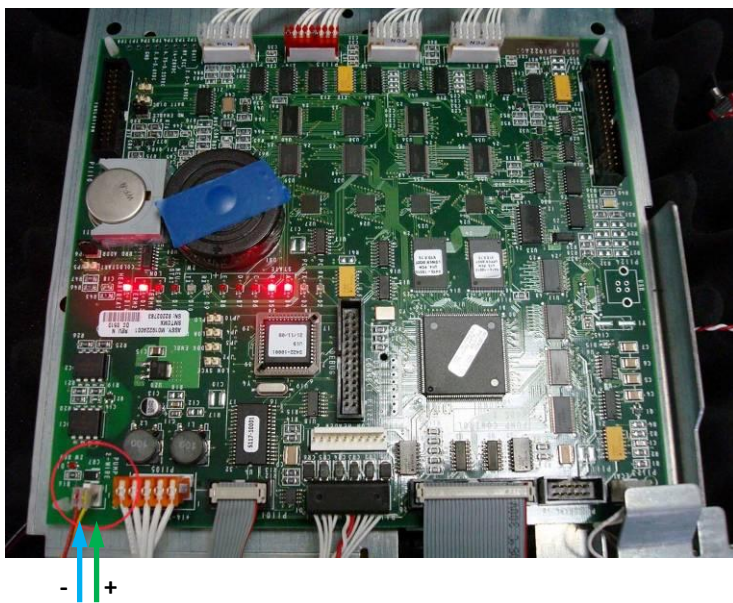

Gilbarco dispenser ASSY M06104A001 rev. B board

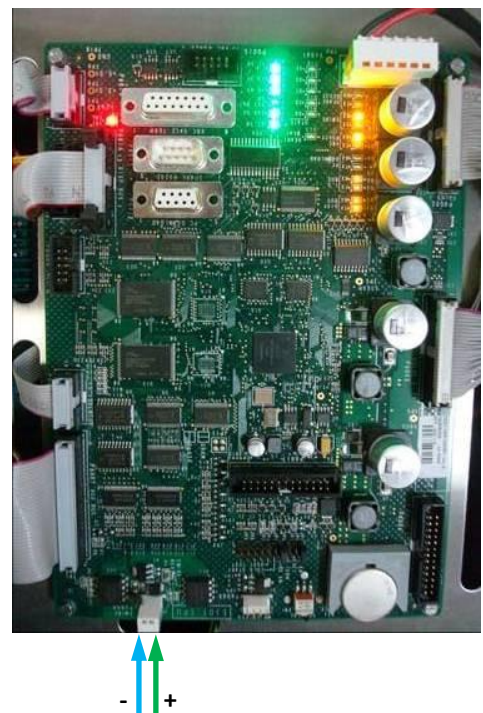

Gilbarco dispenser board

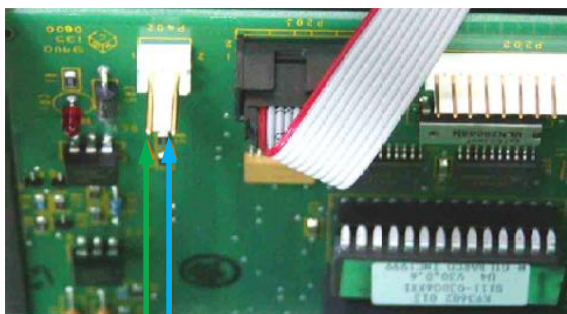

+ -

Gilbarco Euroline dispenser board

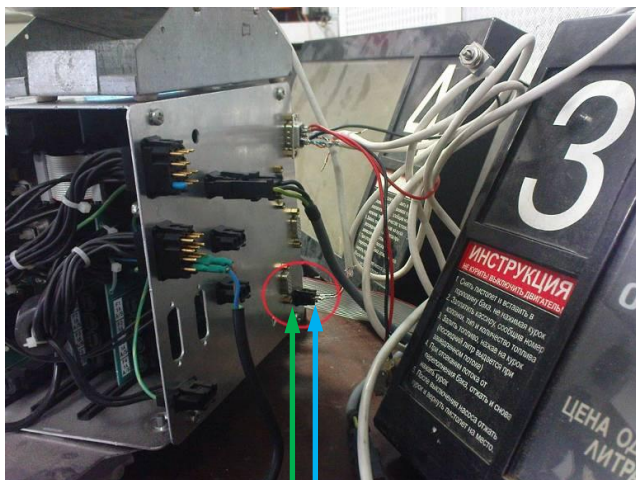

+ -

Gilbarco Highline / Dimension Assy dispenser board



+ -

Gilbarco Endeavor dispenser board



+ -

Gilbarco 3202 series dispenser board

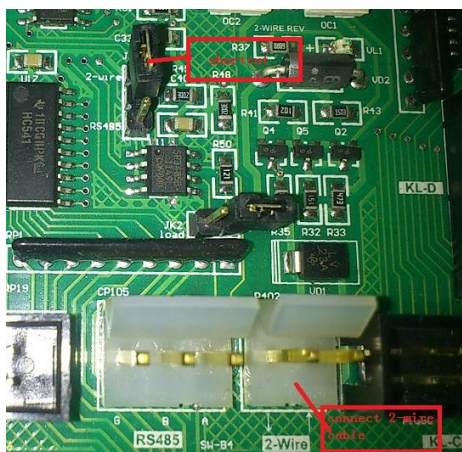

- +



Gilbarco Endeavor dispenser board

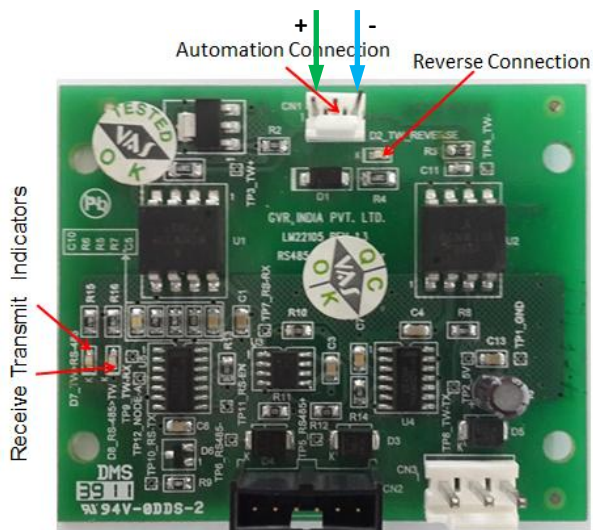

Gilbarco Frontier dispenser board

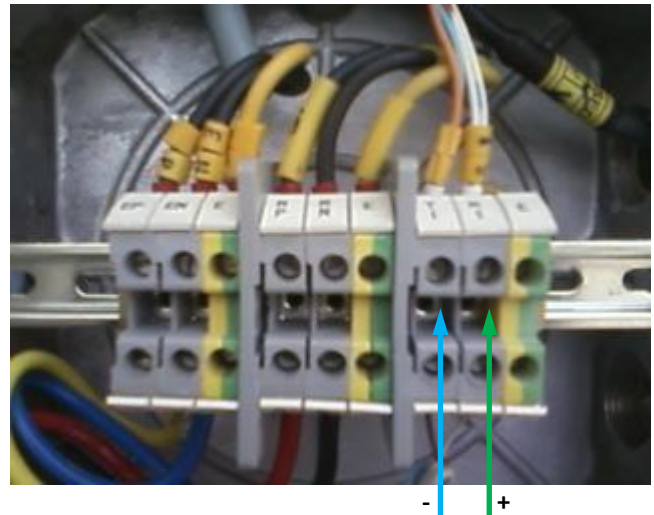

- +

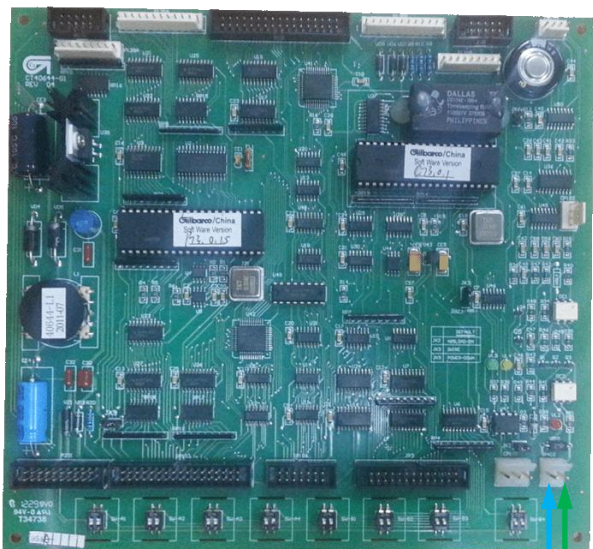

Gilbarco Advantage China motherboard

- +

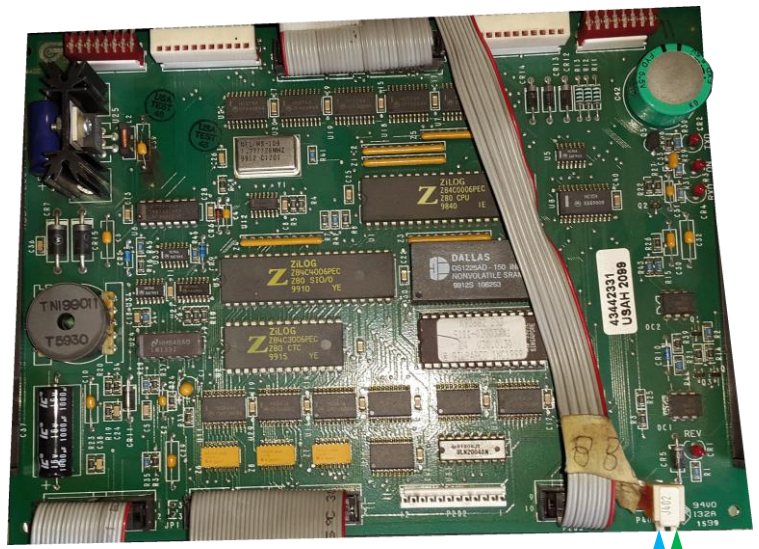

Gilbarco Encore dispenser board

- +

Gilbarco dispenser connection scheme (RS-485 interface)

Connection to some types of Gilbarco dispenser can be made directly without any interface converter.

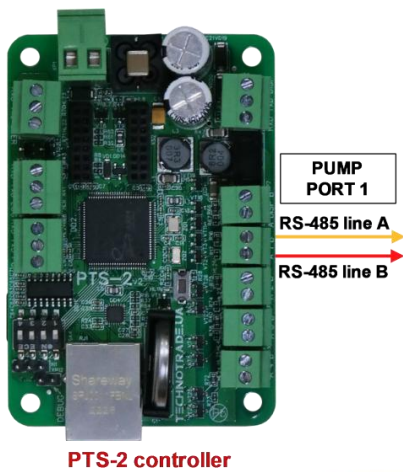

PTS-2 controller

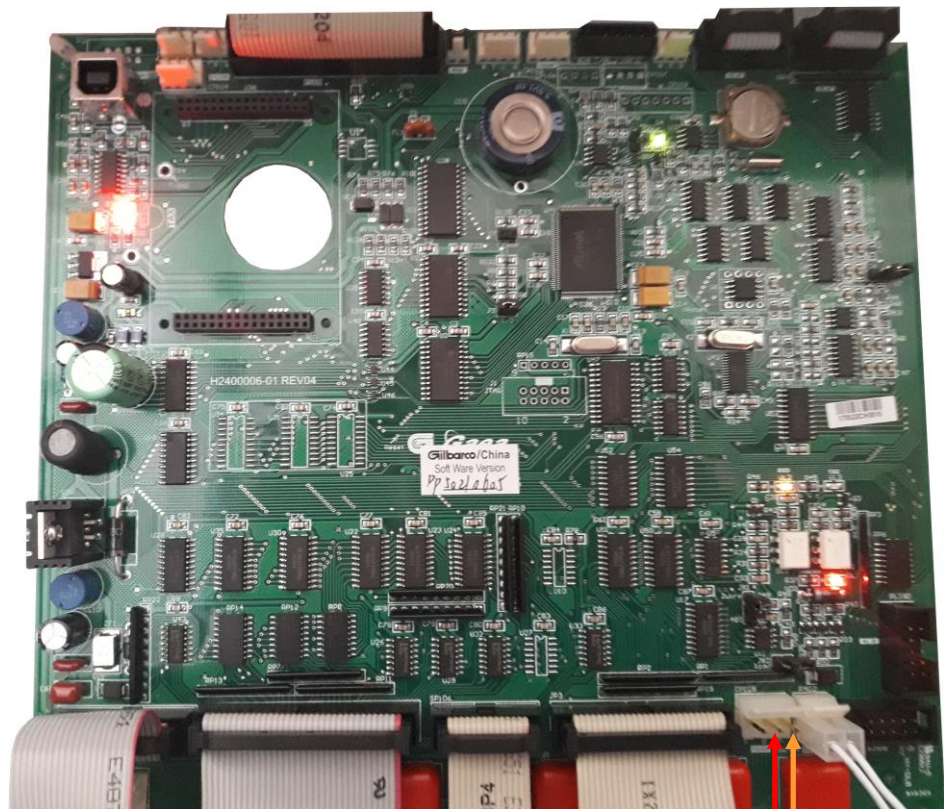

Gilbarco China BK3203 dispenser mainboard

Line B
Line A

Wayne Dresser dispenser connection scheme (RS-485 interface)

Connection to Wayne Dresser dispenser is made directly without any interface converter.

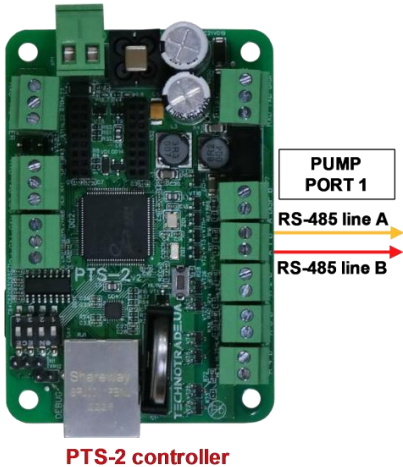

Wayne Dresser iGEM dispenser board

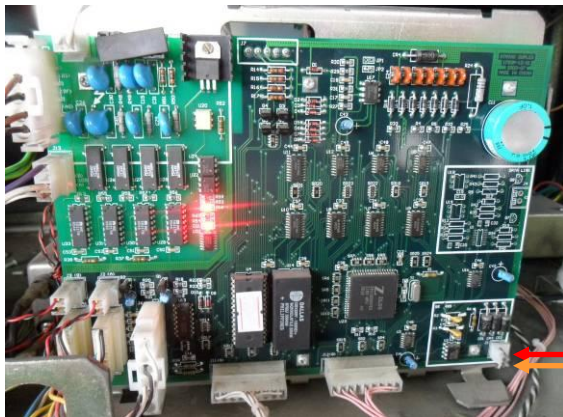

Wayne Dresser STMTAX Duplex dispenser

Wayne Dresser iGEM2 dispenser board

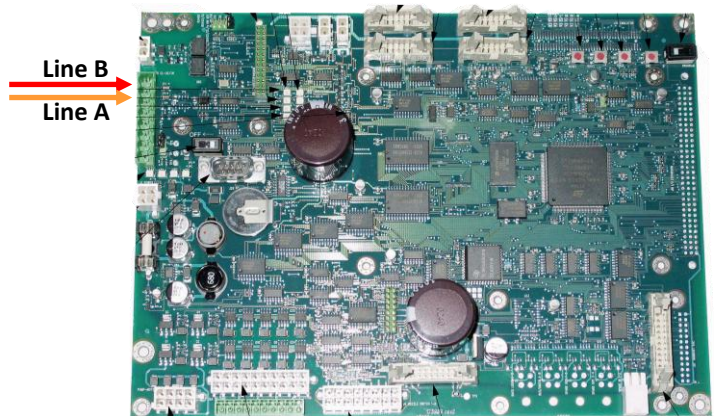

Wayne Dresser x2000/x2003 dispenser interface board



Wayne Dresser V387 dispenser board

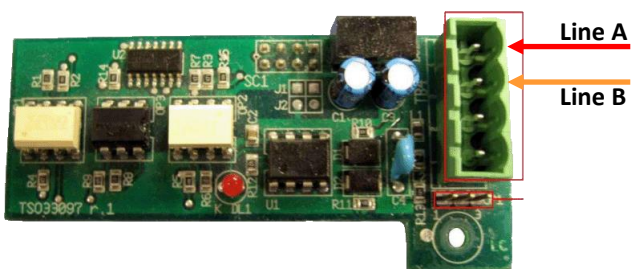

Wayne Dresser Global Vista CNG dispenser interface board

Wayne Dresser dispenser connection scheme (current loop interface)

Connection to Wayne Dresser dispenser is made through 2-wire GB interface converter (<https://www.technotrade.ua/qilbarco-interface-converter.html>), which provides connection of RS-232/RS-485 interfaces to 2-wire current loop interface.



PTS-2 controller

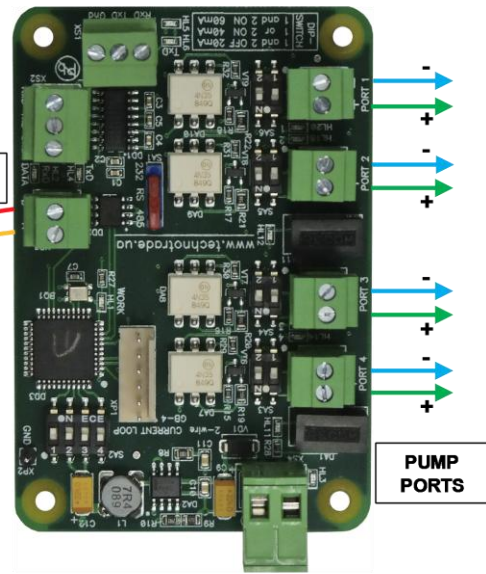
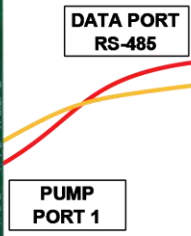

GB-4 interface converter



Wayne Dresser dispenser iGEM board



Wayne Dresser V387 dispenser board



Wayne Dresser iGEM2 dispenser board

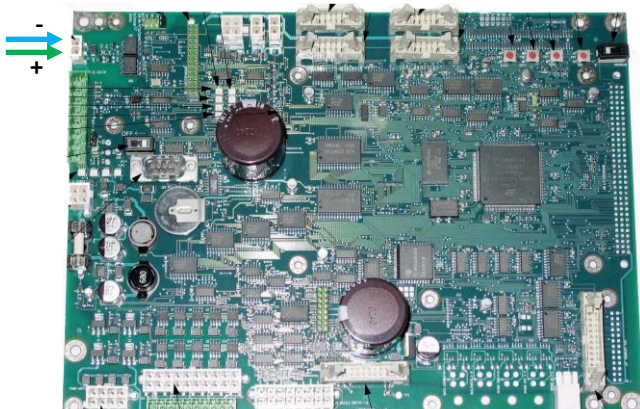

Wayne Dresser STMTAX Duplex dispenser

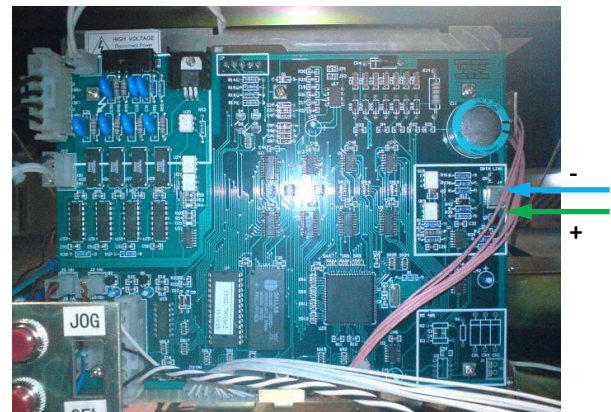

TATSUNO (Japan) dispenser connection scheme

Connection to TATSUNO (Japan) dispenser is made directly without any interface converter.

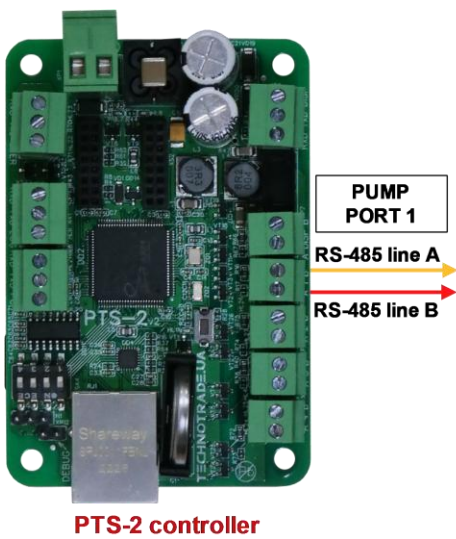

PTS-2 controller

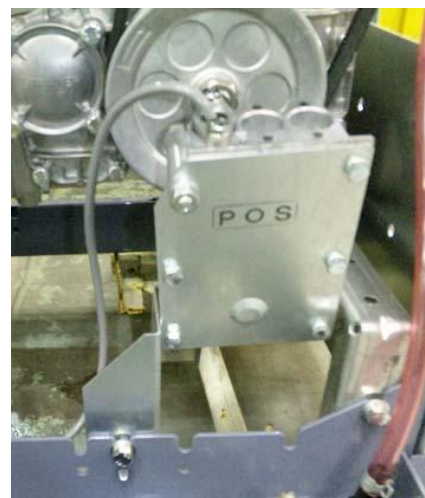
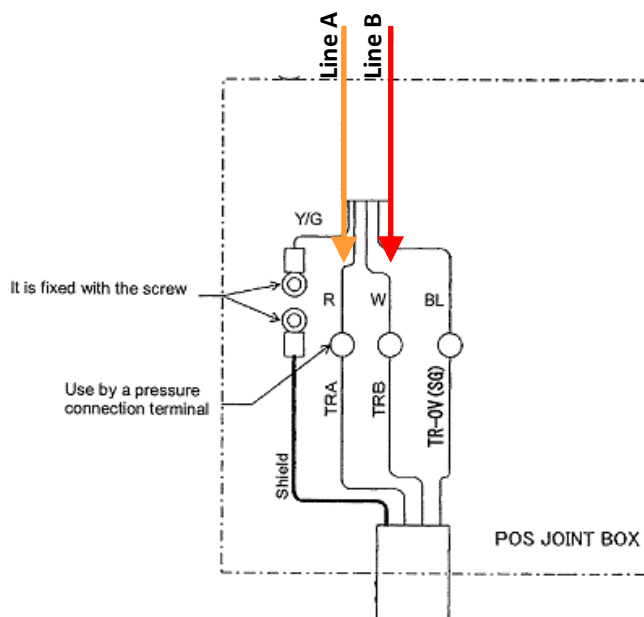

TATSUNO POS joint box

TATSUNO Europe (former Benc) dispenser connection scheme

Connection to TATSUNO Europe (previously named Benc) dispenser is made directly without any interface converter.

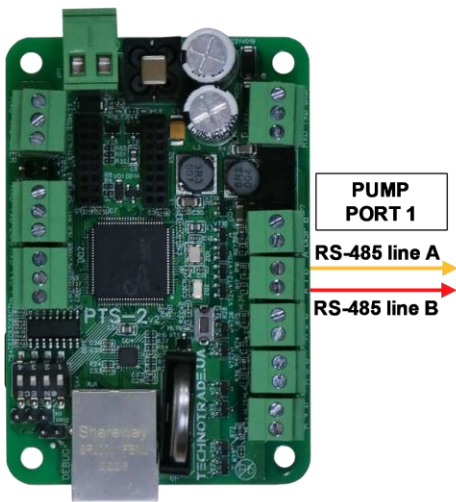

PTS-2 controller

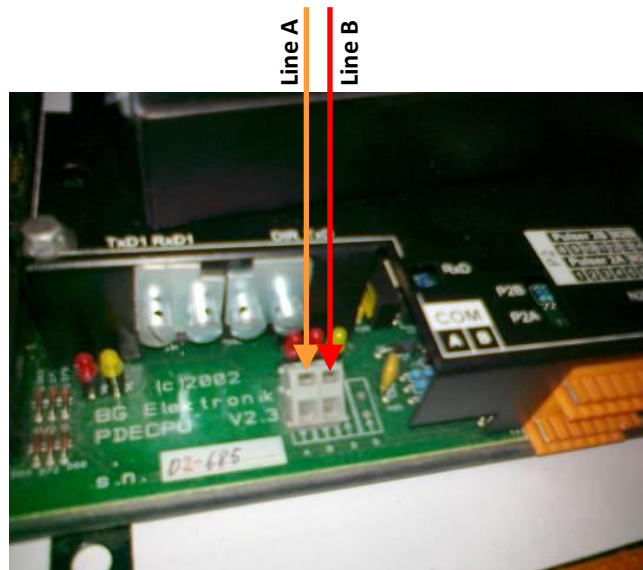

TATSUNO Benc pumphead

Tokheim dispenser connection scheme (3-wire current loop interface)

Connection to Tokheim dispenser is made through 3-wire TH interface converter (<https://www.technotrade.ua/tokheim-interface-converter.html>), which provides connection of RS-232/RS-485 interfaces to 3-wire current loop interface.

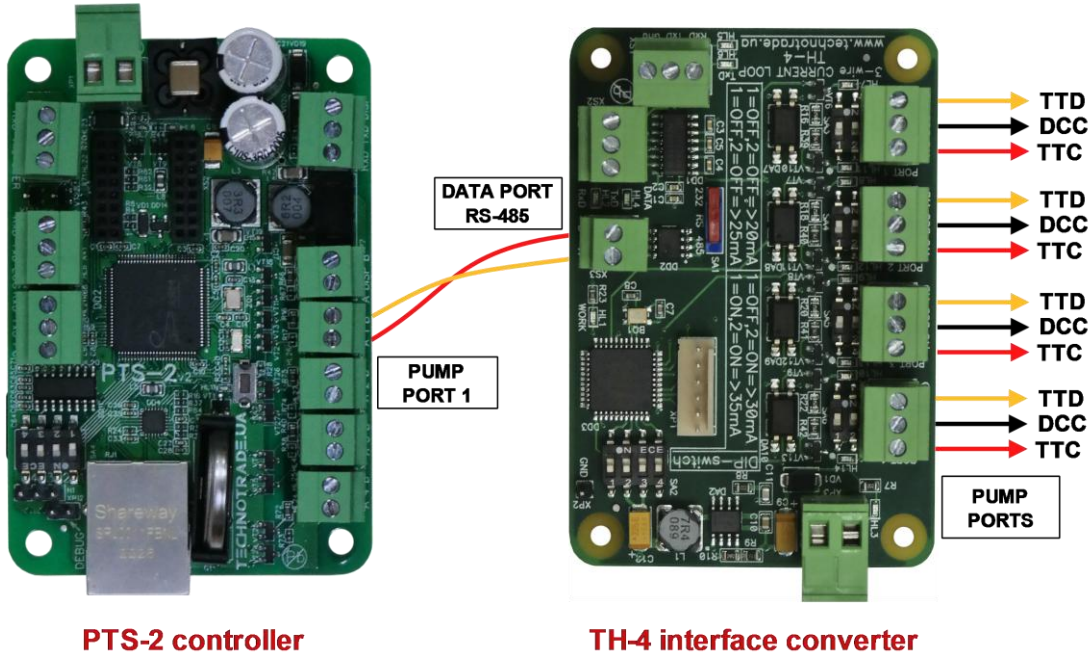

PTS-2 controller

TH-4 interface converter



Tokheim dispenser board

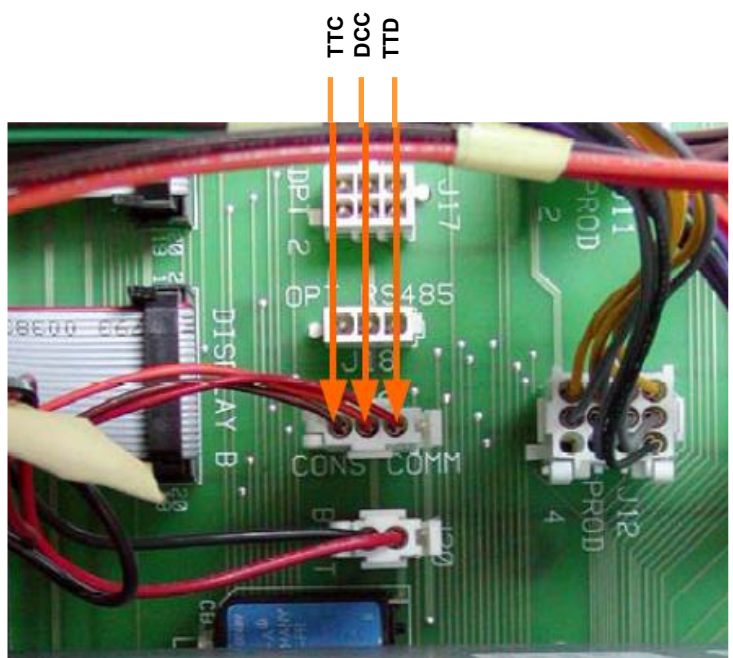

Tokheim dispenser board

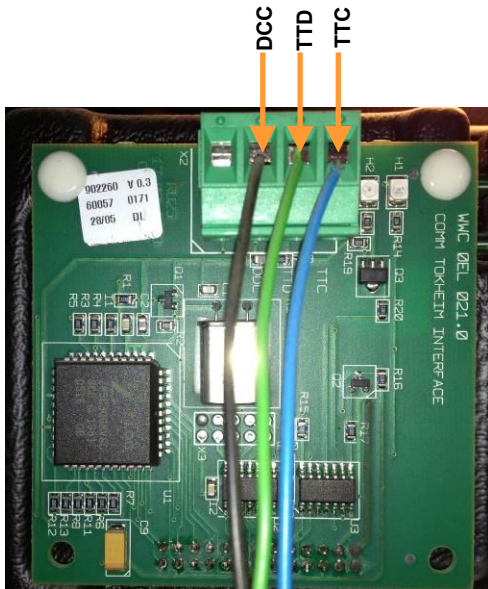

Tokheim dispenser interface board

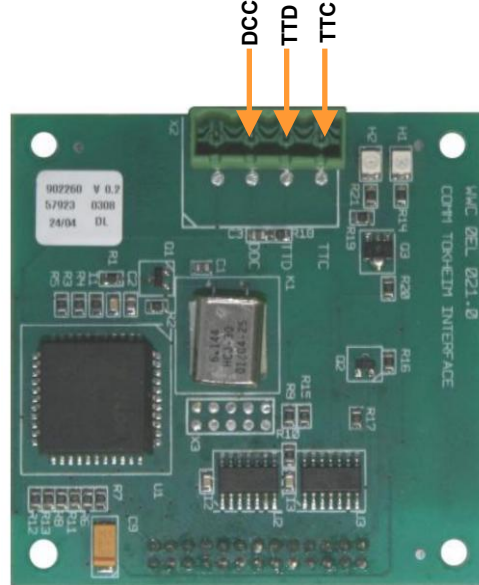

Tokheim dispenser interface board

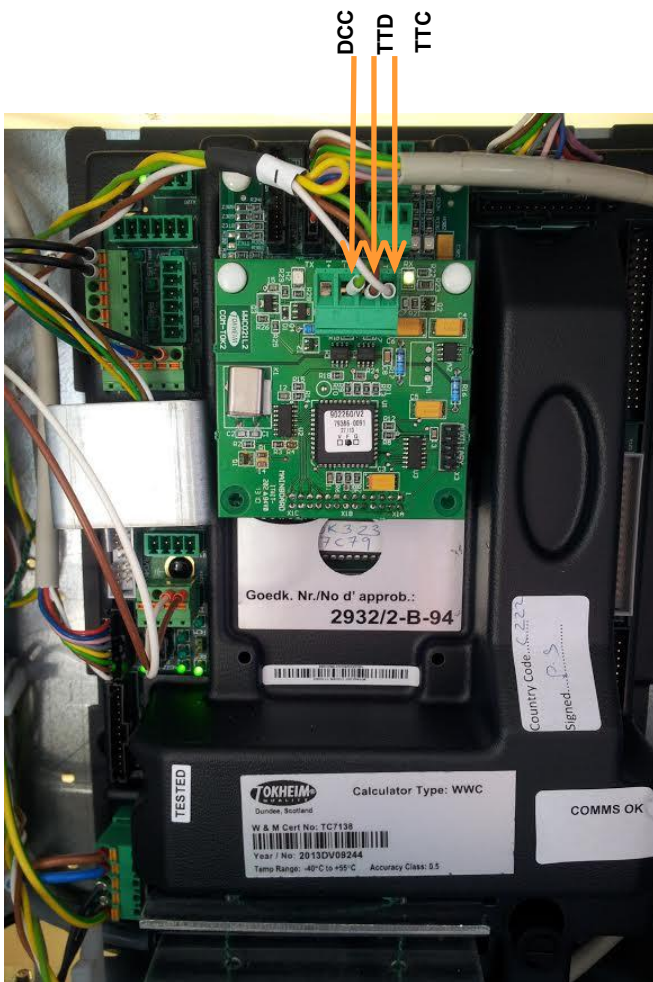

Tokheim dispenser calculator with interface board

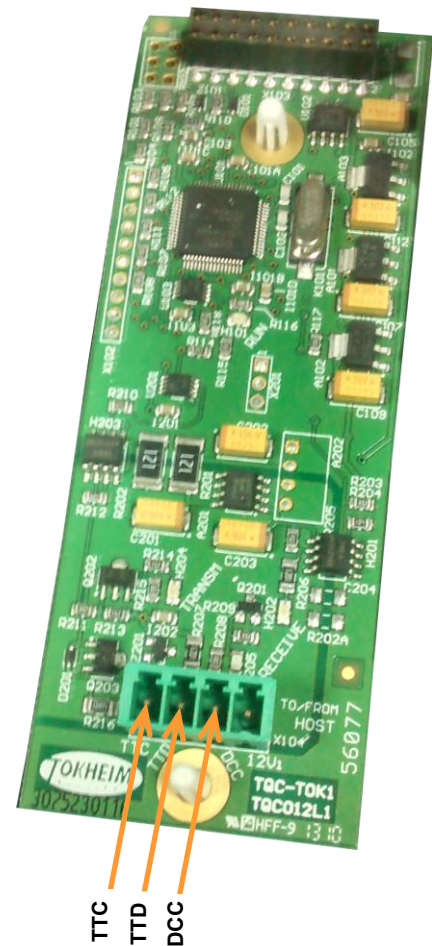

Tokheim dispenser interface board

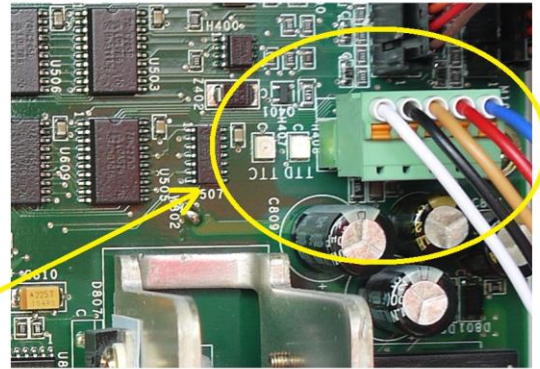

Tokheim Q320T dispenser calculator

Tokheim dispenser connection scheme (RS-485 interface)

Connection to Tokheim dispenser through RS-485 interface is made directly without any interface converter.

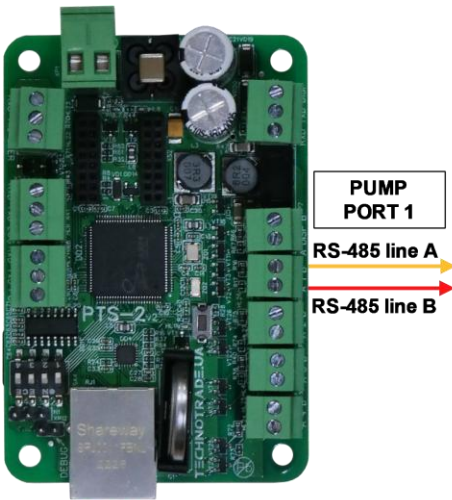

PTS-2 controller

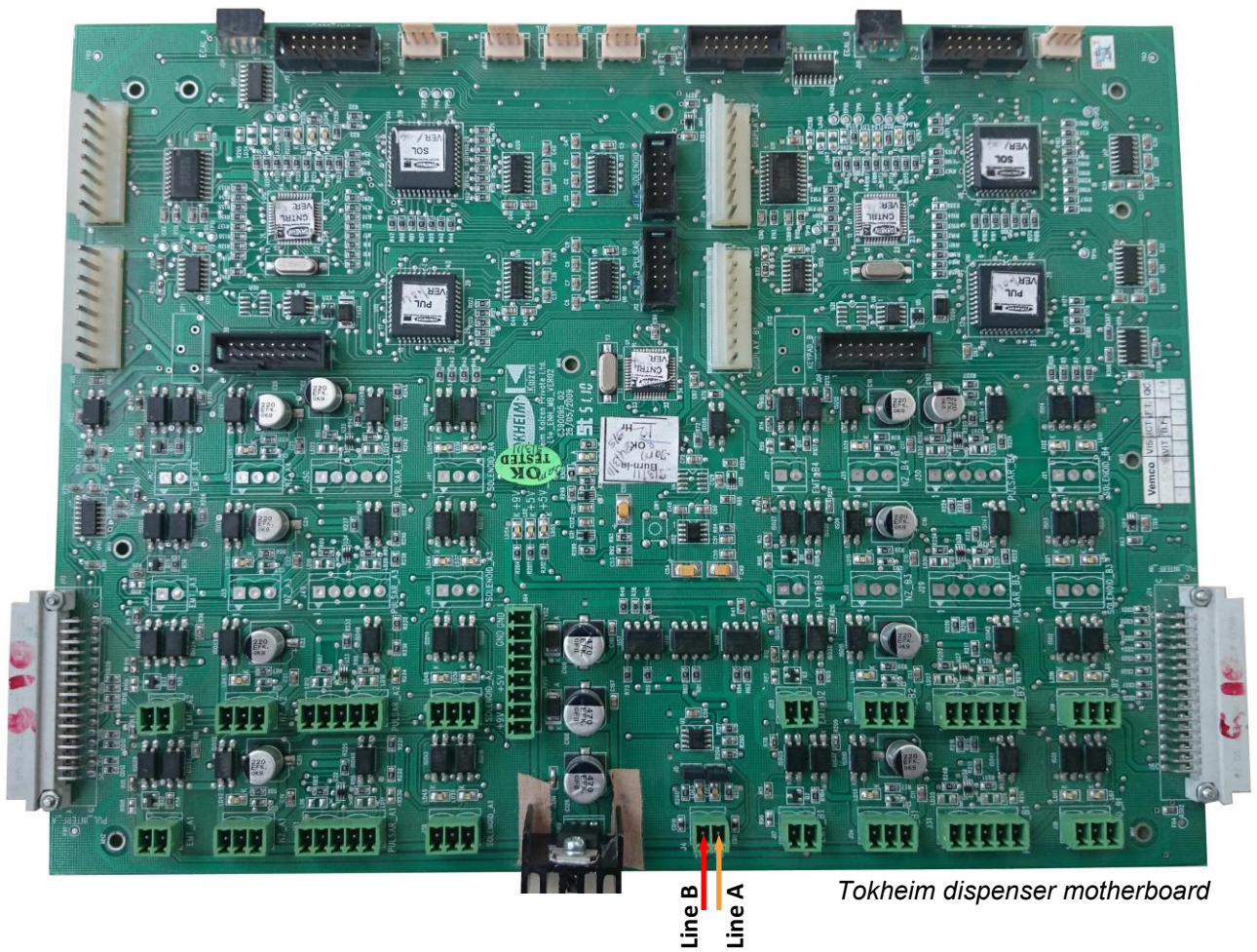

Tokheim dispenser motherboard

Nuovo Pignone dispenser connection scheme (RS-485 interface)

Connection to Nuovo Pignone dispensers with RS-485 interface is made directly without any interface converter. At this Nuovo Pignone dispenser should have an interface board for RS-485 interface and should be adjusted to have Dart protocol.

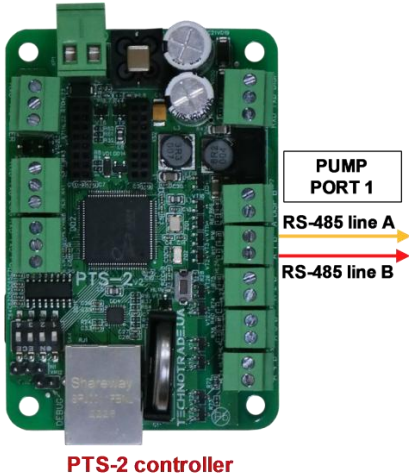

PTS-2 controller

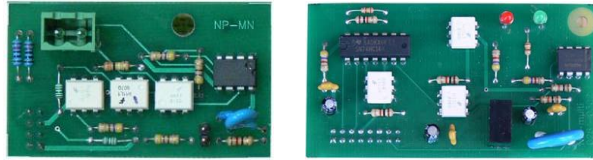

Nuovo Pignone interface boards for RS-485 interface for monoproduct and multiproducts dispensers

More info can be found on:

https://www.technotrade.ua/nuovo_pignone_interface_converter.html



Nuovo Pignone monoproduct dispenser board

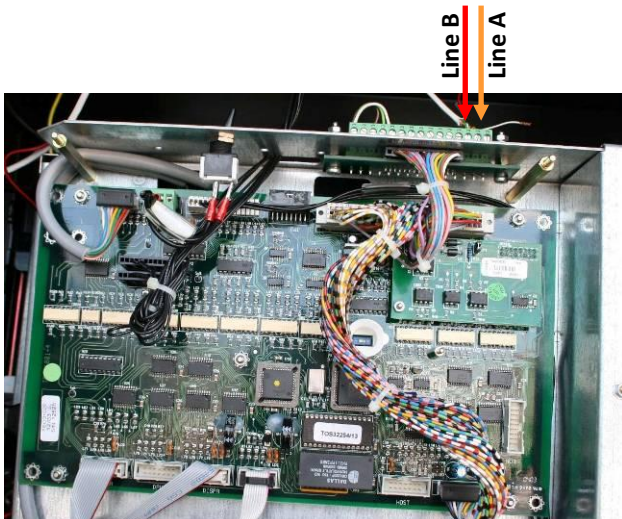

Nuovo Pignone multiproduct dispenser board

Nuovo Pignone dispenser connection scheme (4-wire current loop interface)

Connection to Nuovo Pignone dispensers with 4-wire current loop interface is made through 4-wire NP interface converter (https://www.technotrade.ua/nuovo_pignone_interface_converter.html), which provides connection of RS-232/RS-485 interfaces to 4-wire current loop interface.

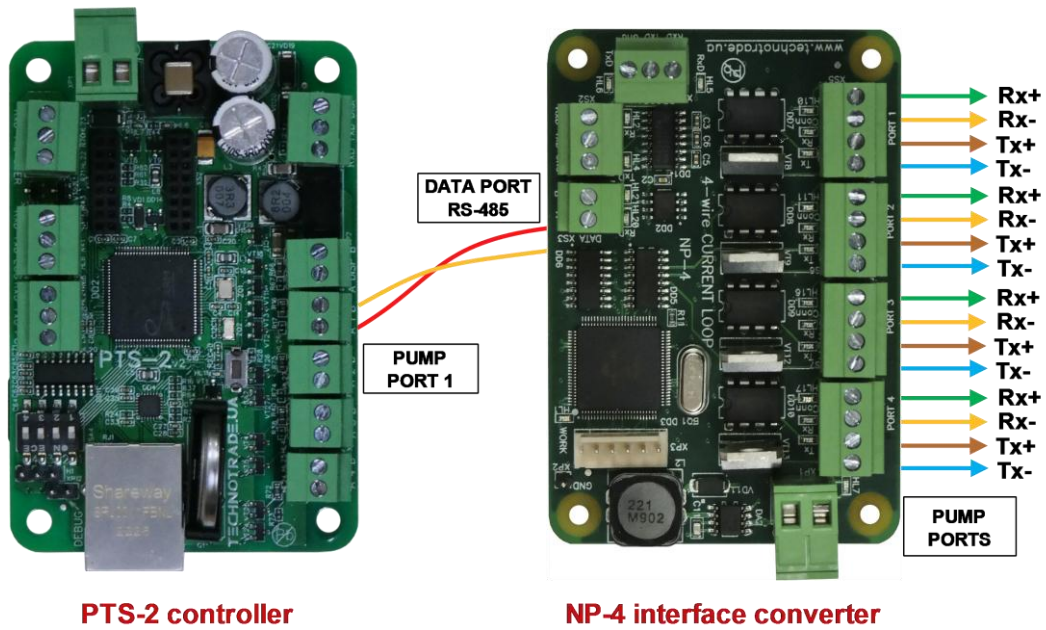

PTS-2 controller

NP-4 interface converter



Nuovo Pignone dispenser board



Nuovo Pignone dispenser board

Logitron dispenser connection scheme (3-wire current loop interface)

Connection to Logitron dispensers with 3-wire current loop interface is made through 3-wire LP interface converter (<https://www.technotrade.ua/logitron-interface-converter.html>), which provides connection of RS-232/RS-485 interfaces to 3-wire current loop interface.

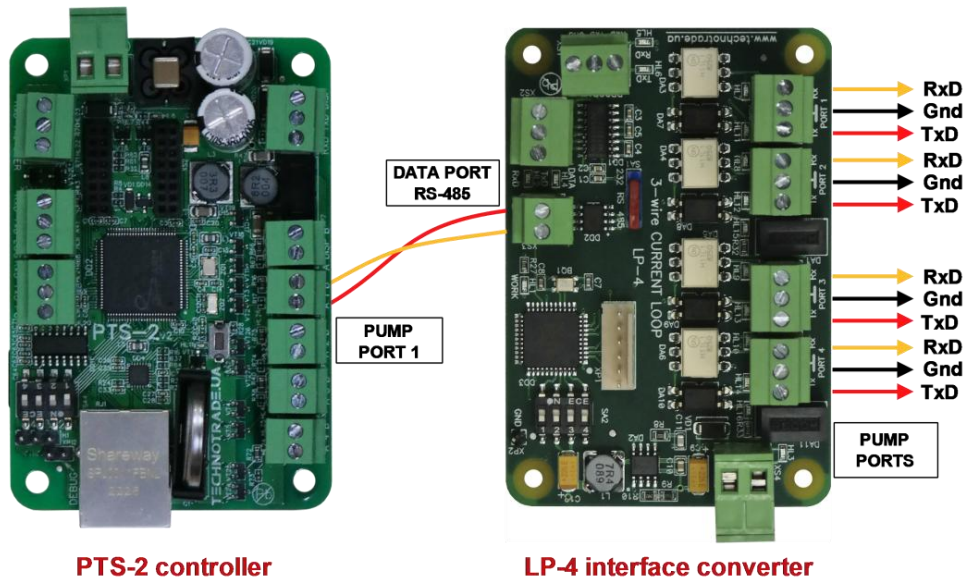

PTS-2 controller

LP-4 interface converter

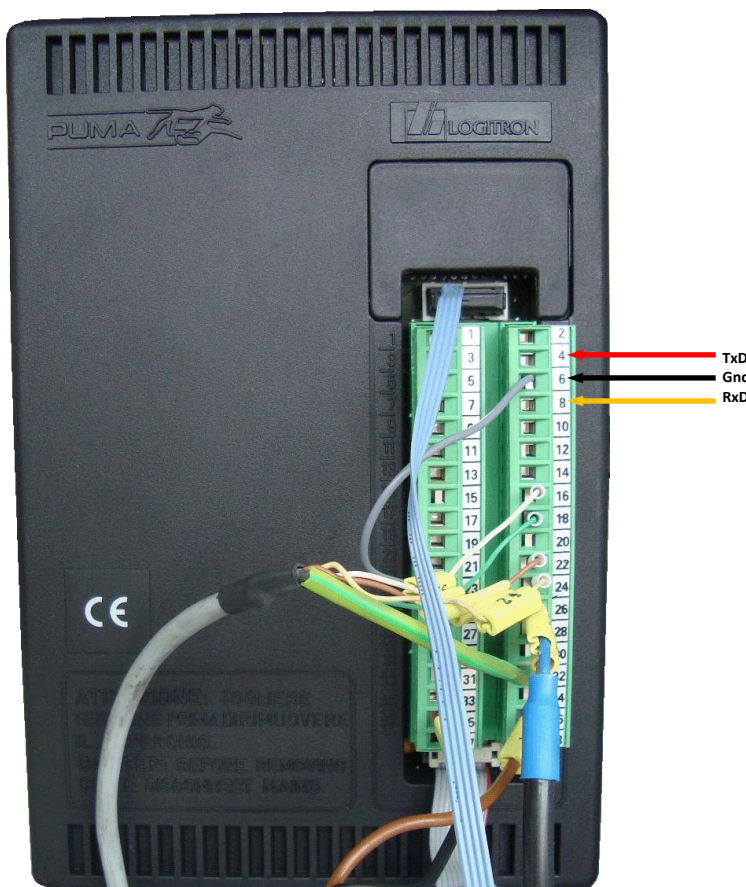

PUMA Logitron computer

Bennett dispenser connection scheme (RS-485 interface)

Connection to Bennett dispensers with RS-485 interface is made directly without any interface converter.

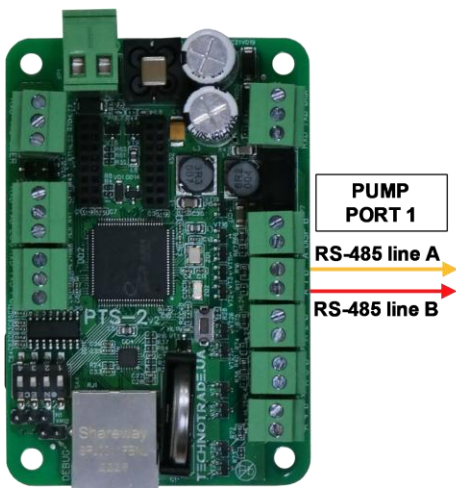

PTS-2 controller

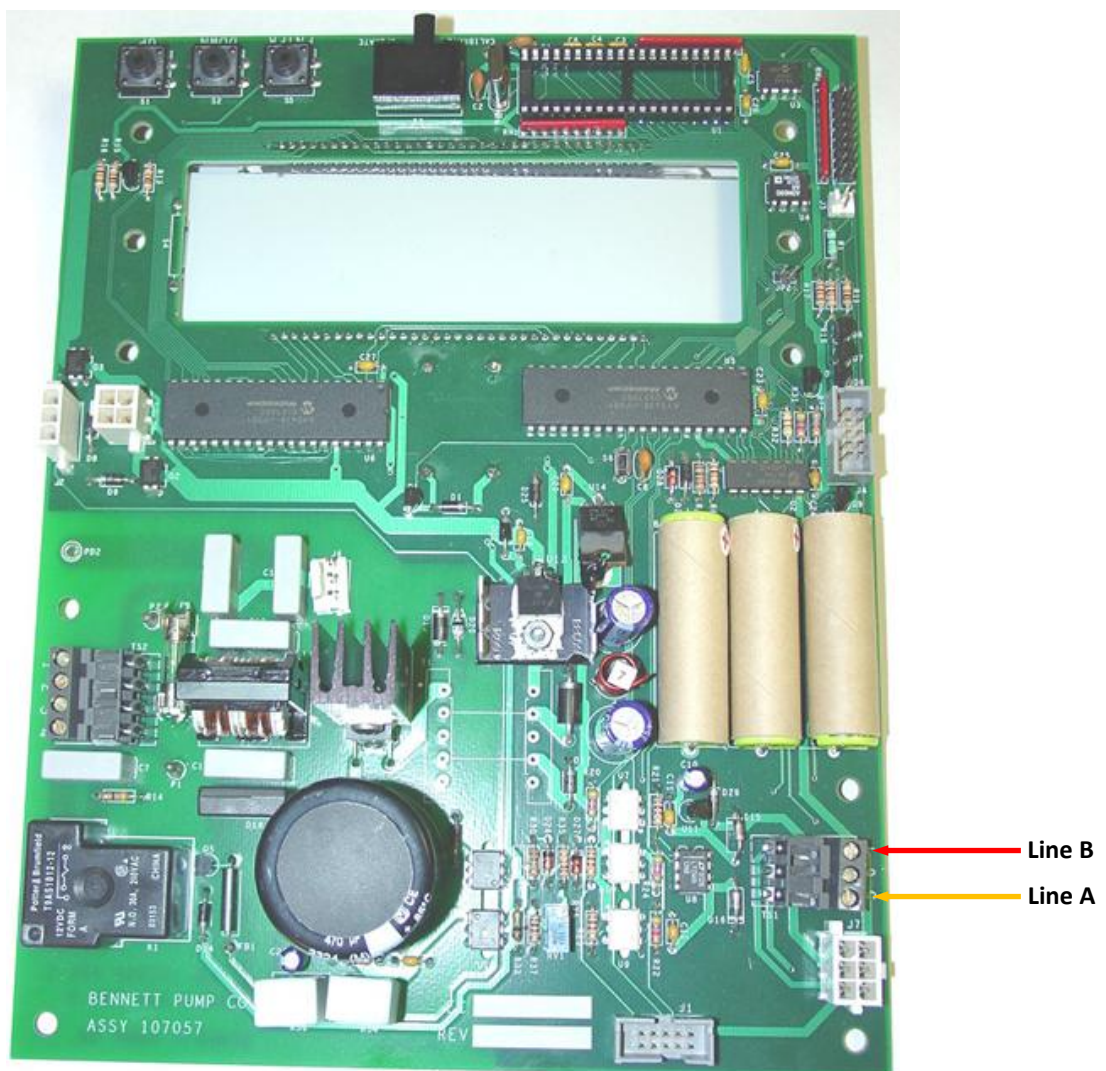

Bennett dispenser board

Bennett dispenser connection scheme (2-wire current loop interface)

Connection to Bennett dispensers with 2-wire current loop interface is made through 2-wire GB interface converter (<https://www.technotrade.ua/gilbarco-interface-converter.html>), which provides connection of RS-232/RS-485 interfaces to 2-wire current loop interface.

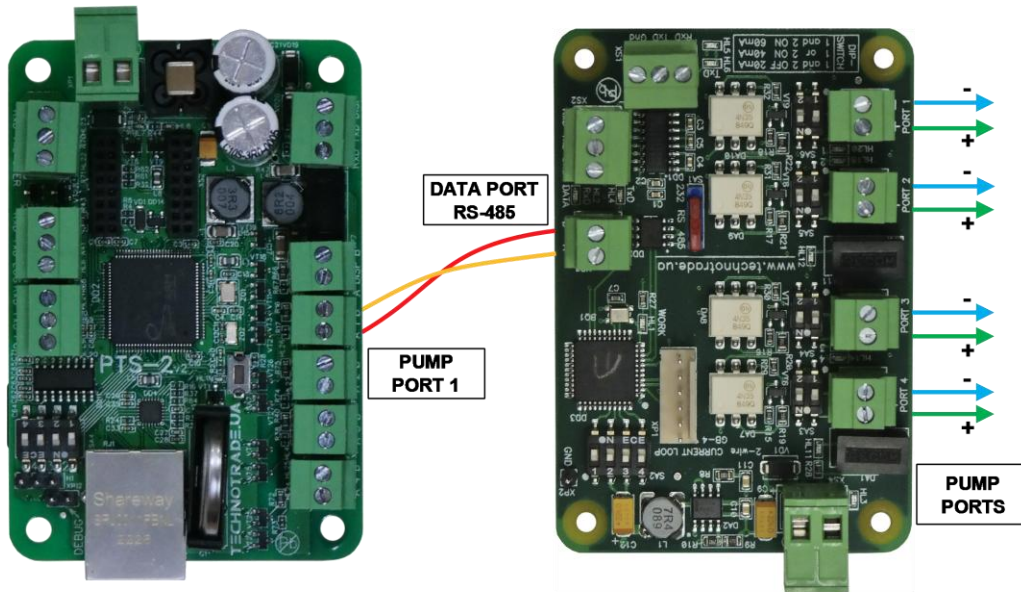

PTS-2 controller

GB-4 interface converter

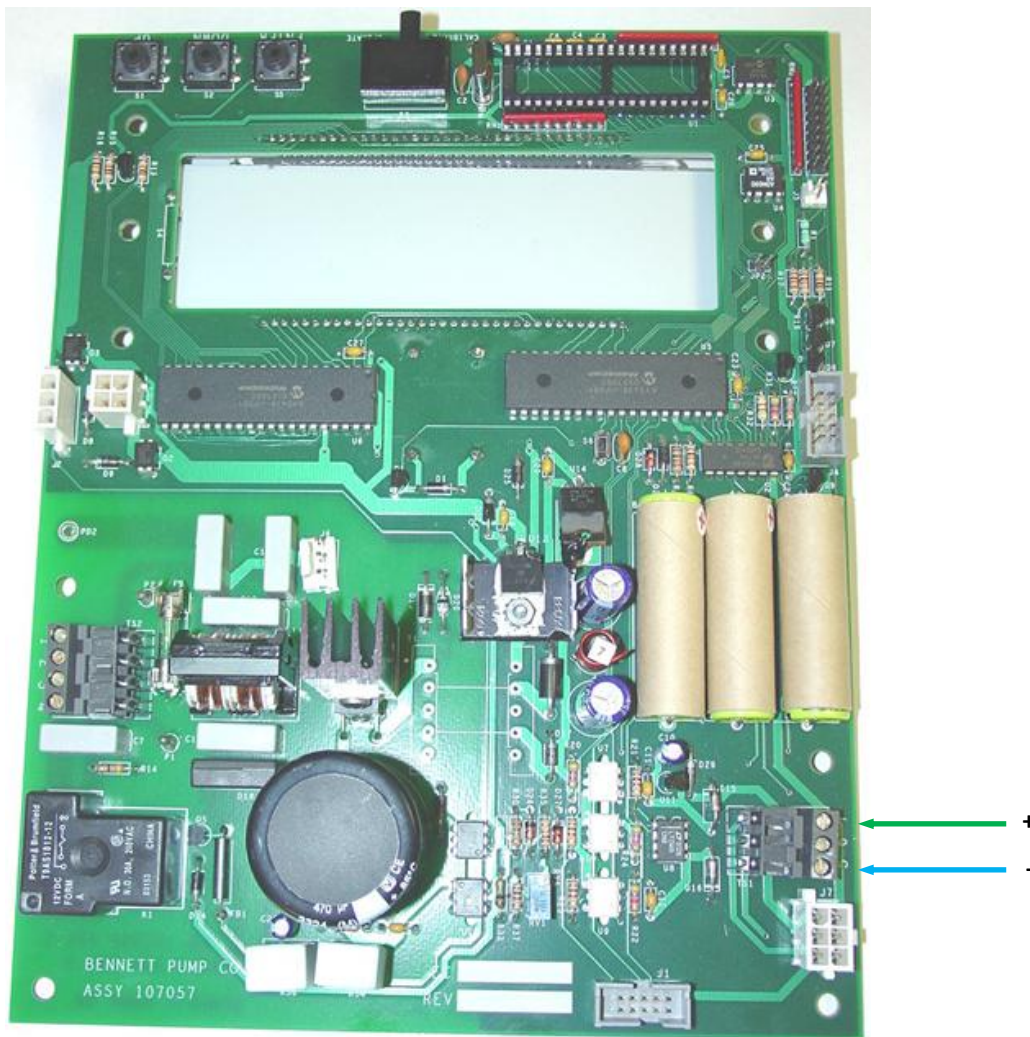

Bennett dispenser board

Batchen Email dispenser connection scheme

Connection to Batchen dispenser is made through 2-wire GB interface converter (<https://www.technotrade.ua/qilbarco-interface-converter.html>), which provides connection of RS-232/RS-485 interfaces to 2-wire current loop interface.

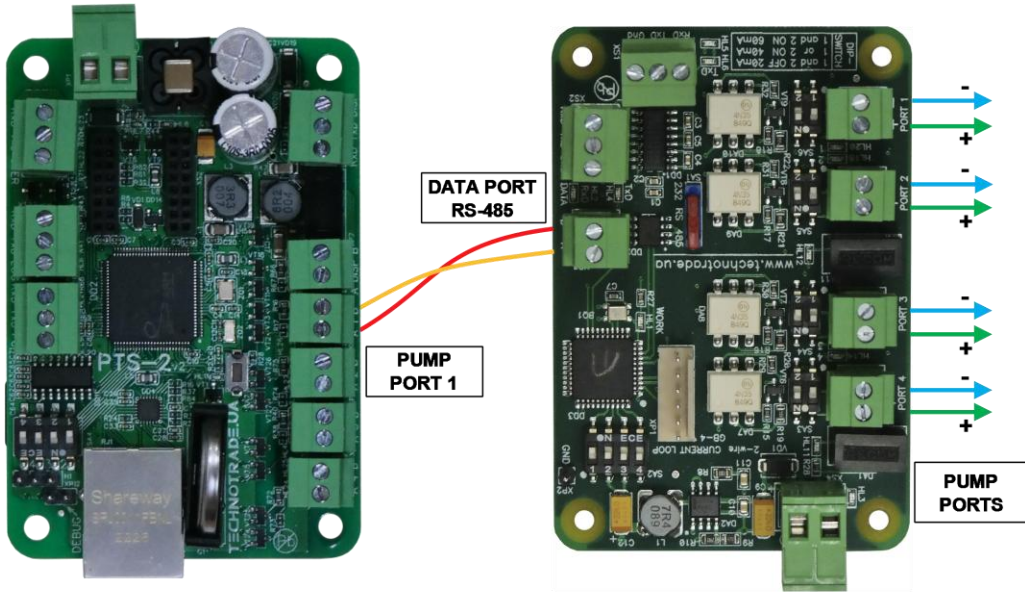

PTS-2 controller

GB-4 interface converter

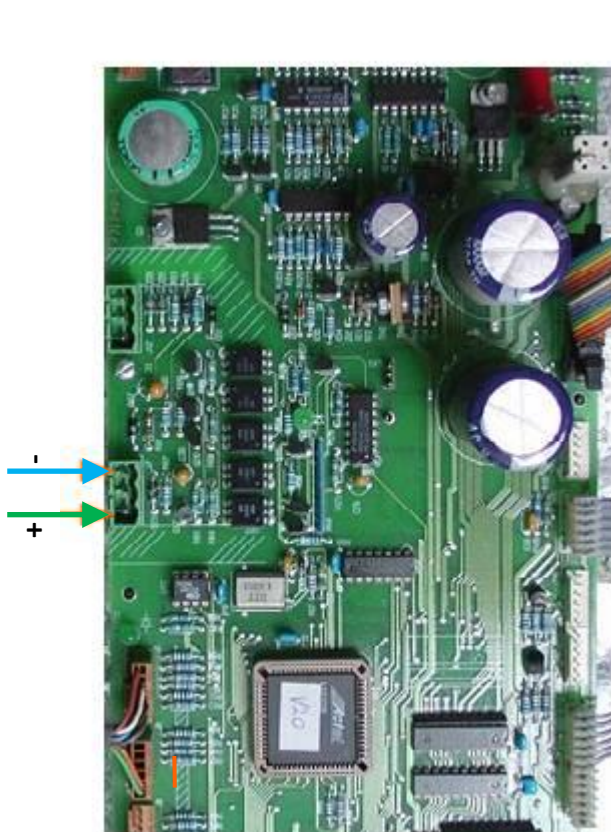

Batchen dispenser board

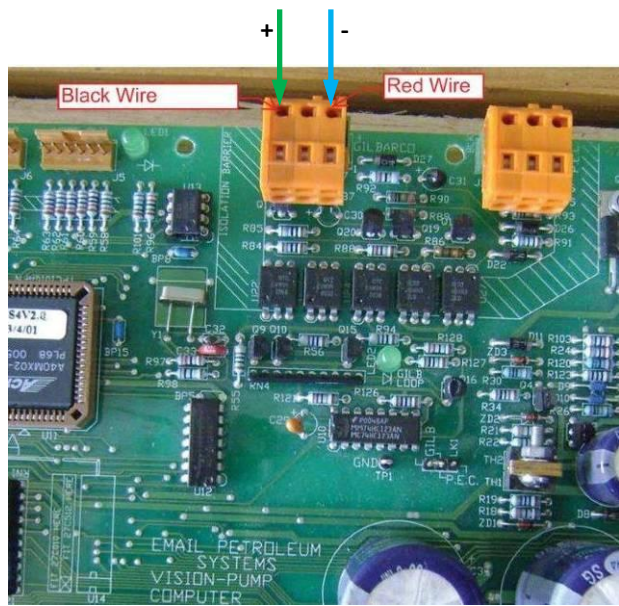

Batchen dispenser board

Scheidt & Bachmann T20 dispenser connection scheme

Connection to Scheidt&Bachmann T20 dispenser is made through S&B T20 interface converter board.

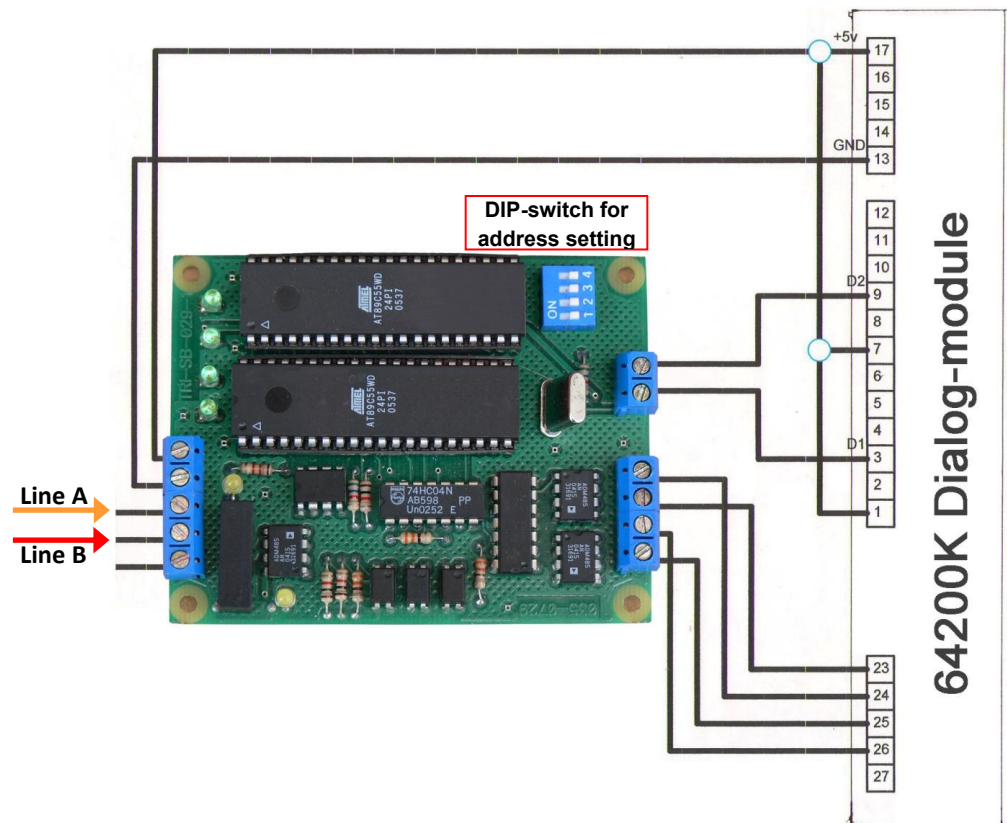
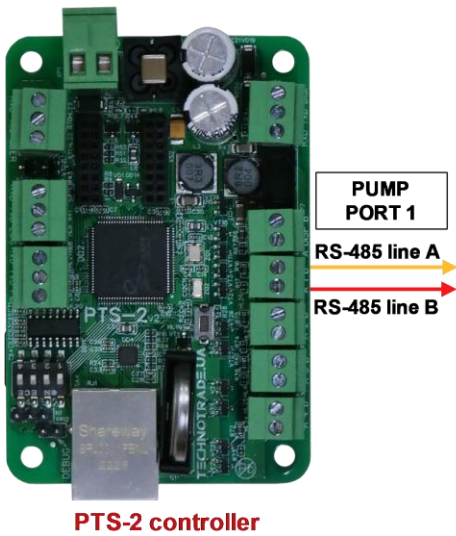

Address setting on S&B T20 interface converter board using a DIP-switch

Address	1 & 2	3 & 4	5 & 6	7 & 8	9 & 10	11 & 12	13 & 14	15 & 16
DIP 1	OFF	OFF	OFF	OFF	ON	ON	ON	ON
DIP 2	OFF	OFF	ON	ON	OFF	OFF	ON	ON
DIP 3	OFF	ON	OFF	ON	OFF	ON	OFF	ON
DIP 4	OFF	OFF	OFF	OFF	OFF	OFF	OFF	OFF

Neotec dispenser connection scheme

Connection to Neotec dispenser mainboard is made directly without any interface converter.

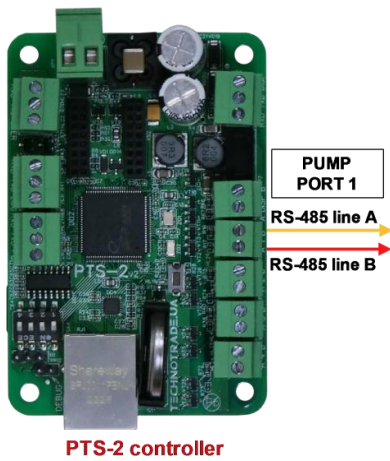

PTS-2 controller

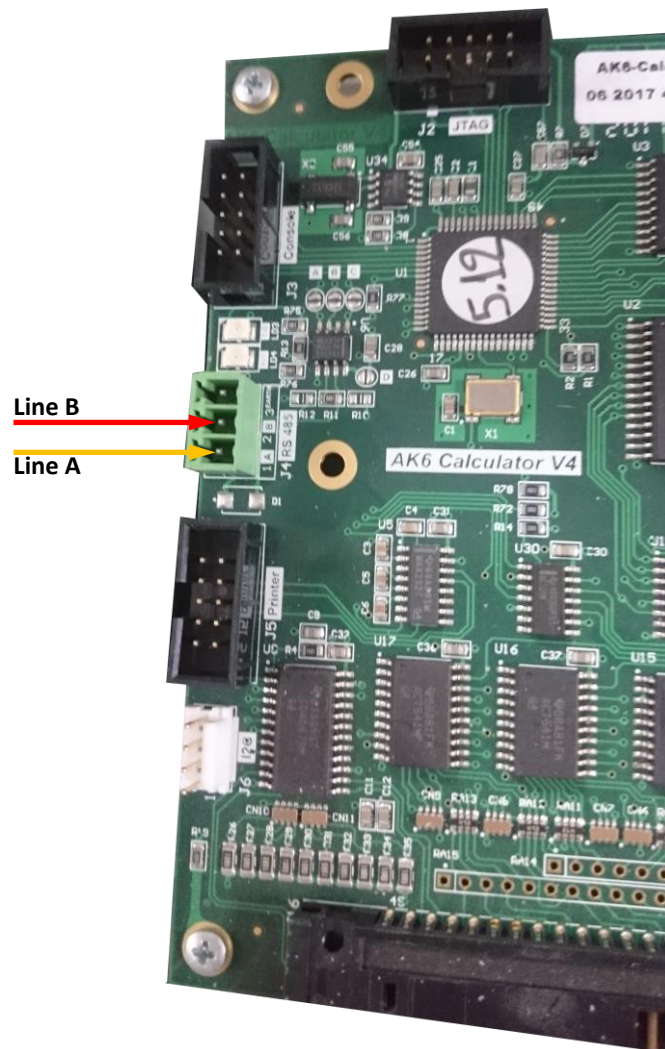

AK6 mainboard

Coptron dispenser connection scheme

Connection to Coptron pumphead is made directly without any interface converter.

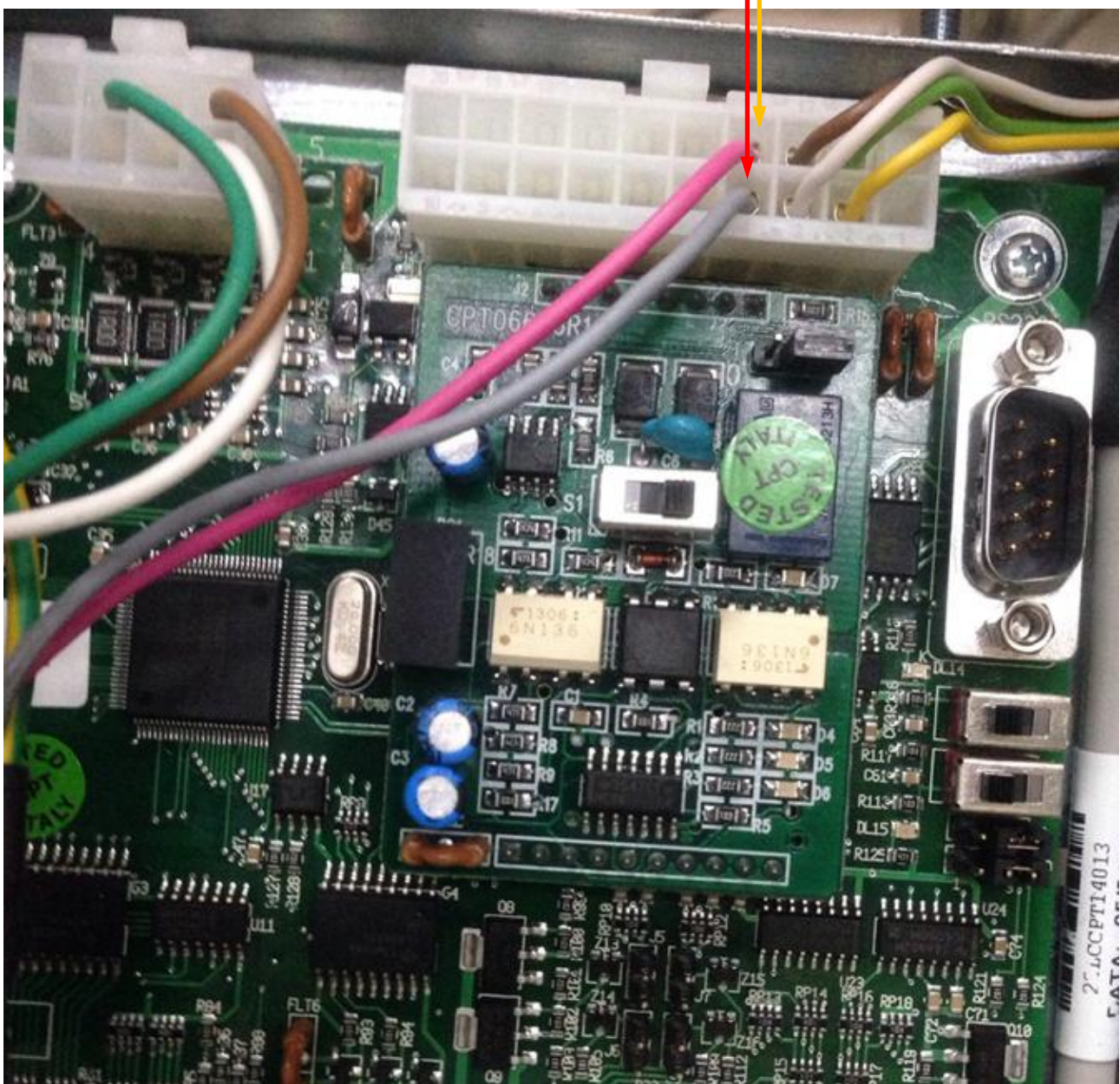
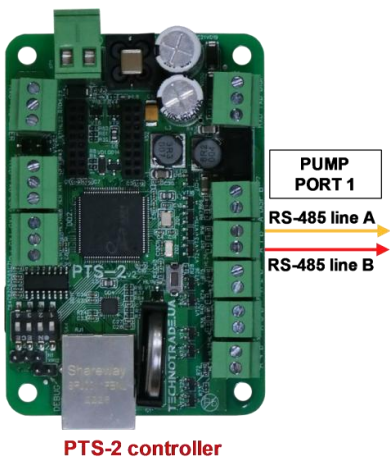

Coptron pumphead

Midco dispenser connection scheme

Connection to Midco pumphead is made directly without any interface converter.

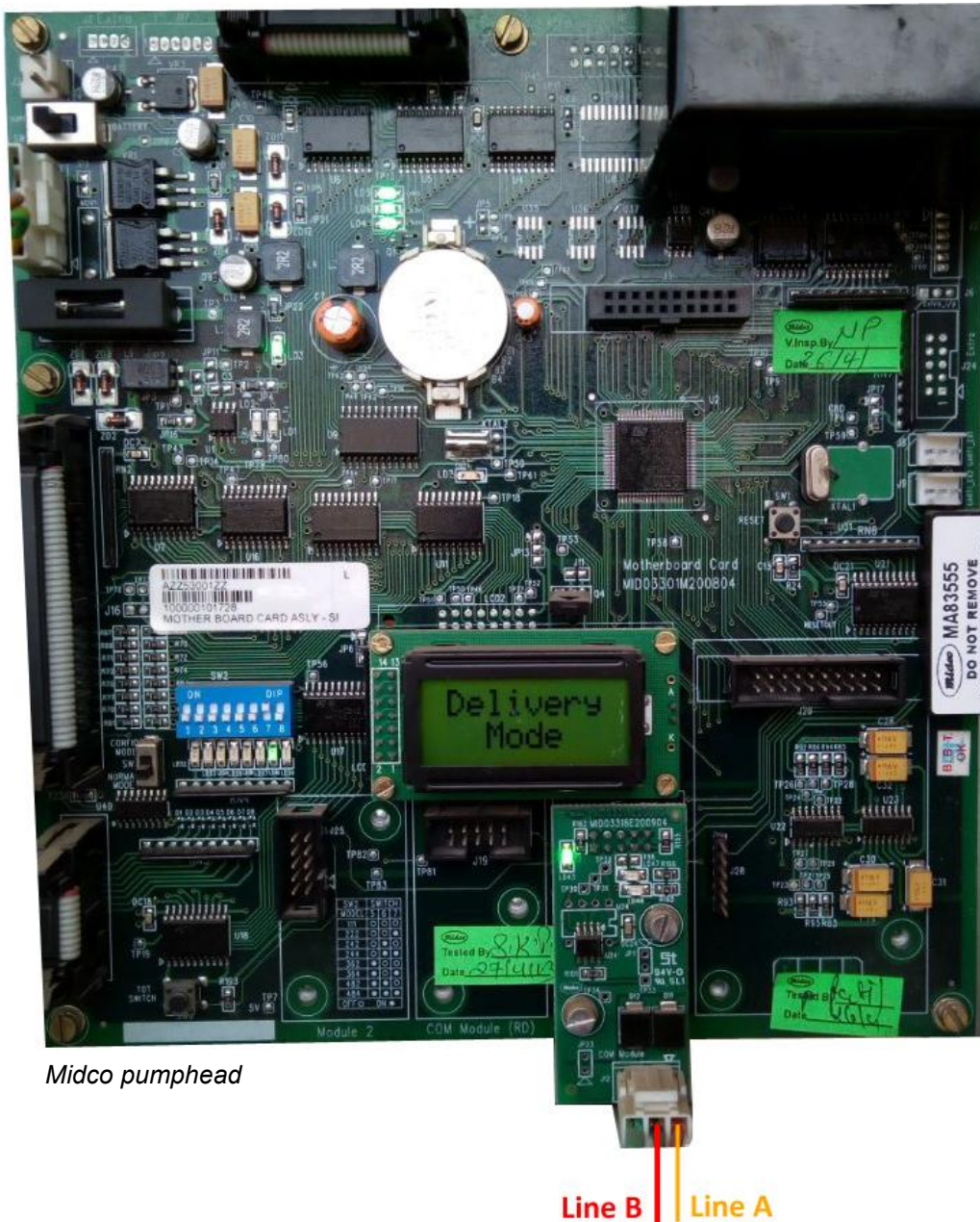
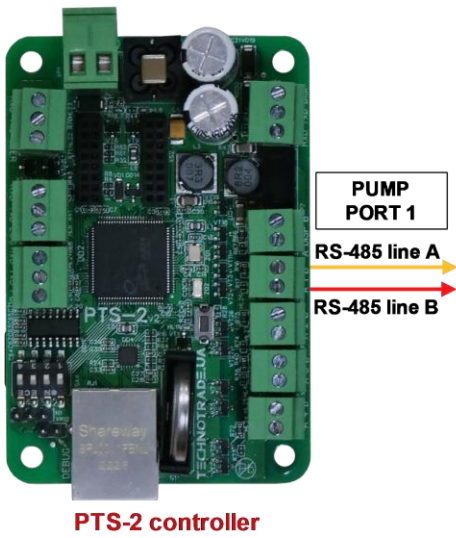

Midco pumphead

Petrotec dispenser connection scheme

Connection to Petrotec dispenser is made through 2-wire GB interface converter (<https://www.technotrade.ua/qilbarco-interface-converter.html>), which provides connection of RS-232/RS-485 interfaces to 2-wire current loop interface.

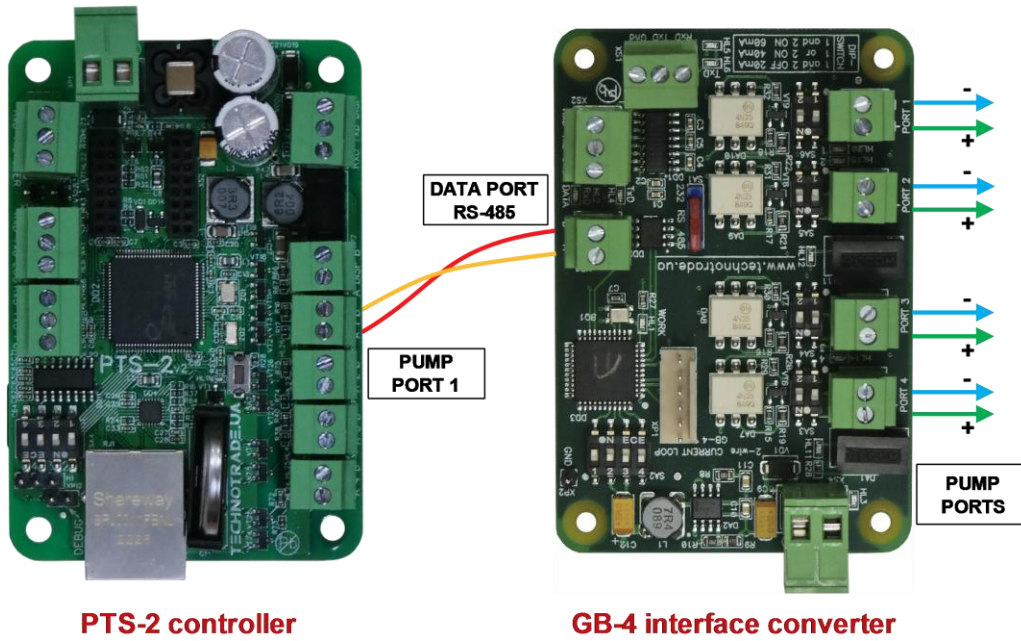

PTS-2 controller

GB-4 interface converter

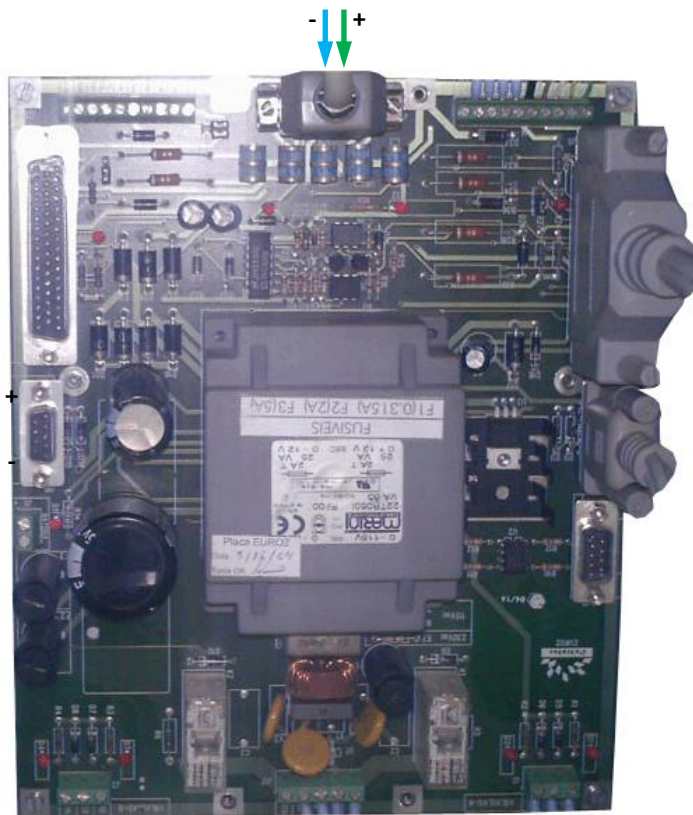

Petrotec dispenser board

Galileo dispenser connection scheme

Connection to Galileo dispenser is made through 2-wire GB interface converter (<https://www.technotrade.ua/qilbarco-interface-converter.html>), which provides connection of RS-232/RS-485 interfaces to 2-wire current loop interface.

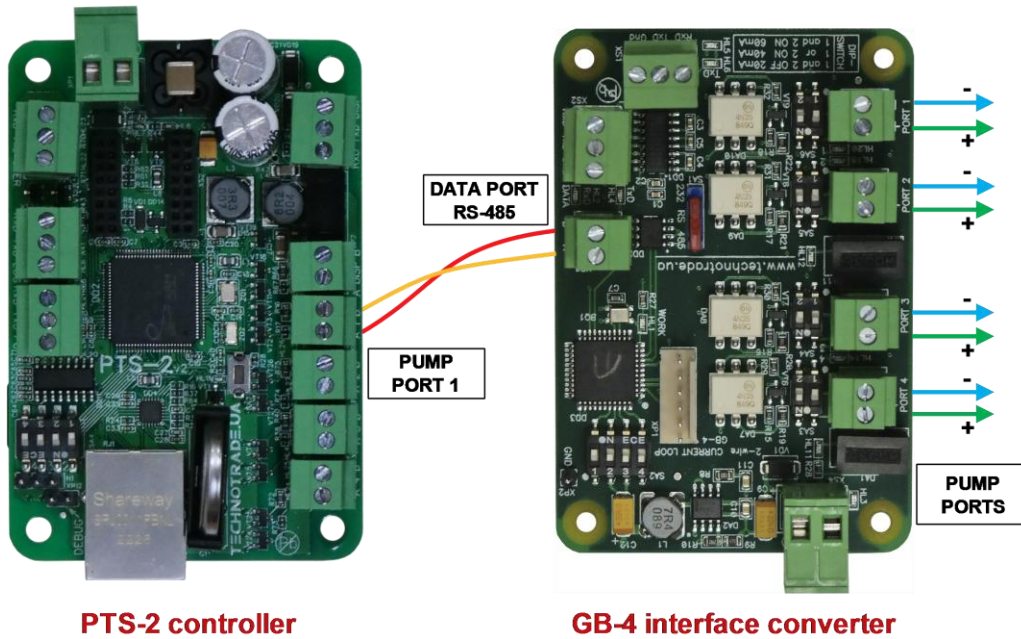

PTS-2 controller

GB-4 interface converter

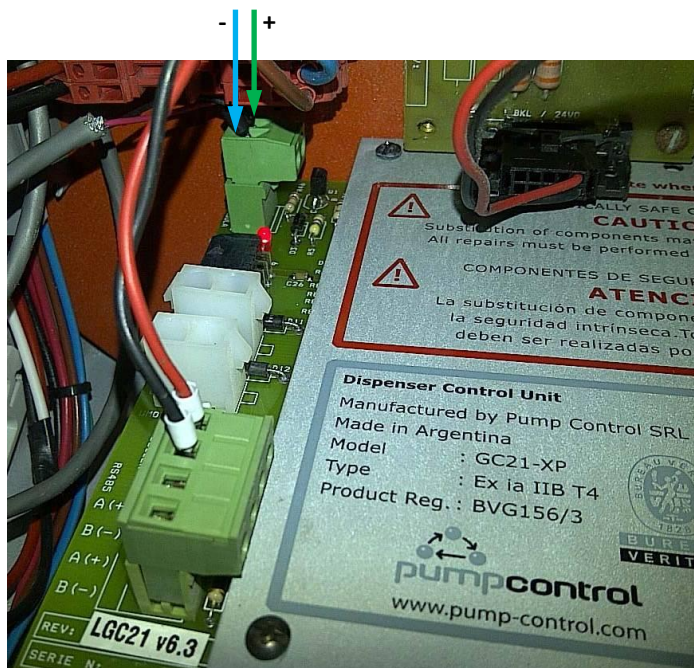

Galileo dispenser board

Prowalco dispenser connection scheme

Connection to Prowalco dispenser is made through 2-wire GB interface converter (<https://www.technotrade.ua/qilbarco-interface-converter.html>), which provides connection of RS-232/RS-485 interfaces to 2-wire current loop interface.

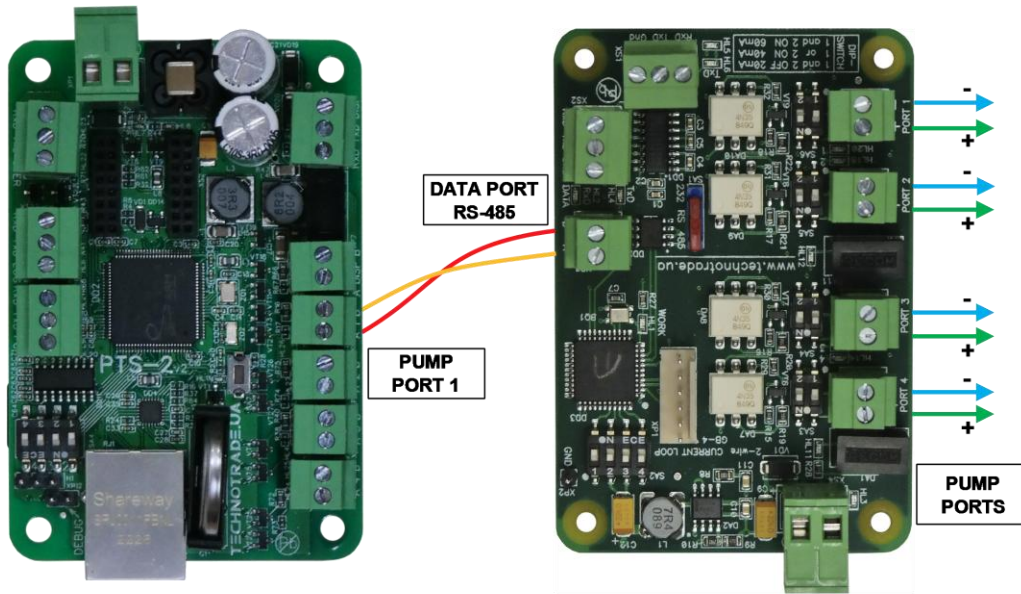

PTS-2 controller

GB-4 interface converter

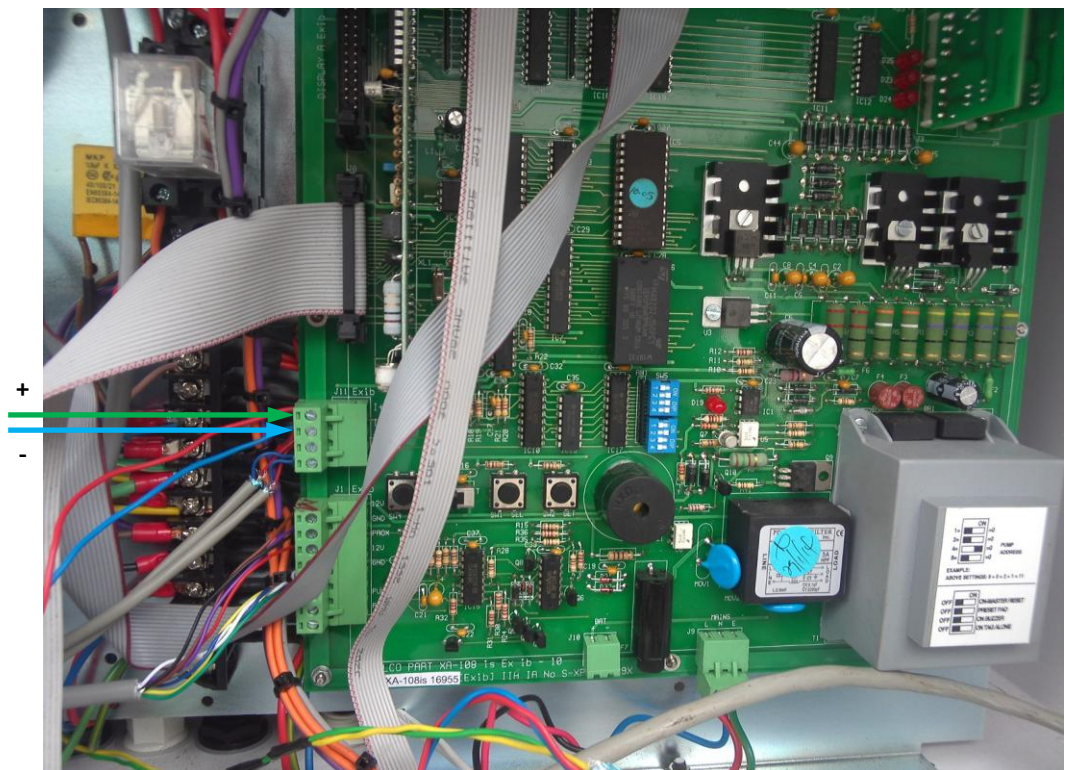

Prowalco dispenser board

Emgaz Dragon / Fornovo LPG dispenser with EsiWelma pumphead connection scheme

Connection to EsiWelma pumphead is made through 3-wire LP interface converter (<https://www.technotrade.ua/logitron-interface-converter.html>), which provides connection of RS-232/RS-485 interfaces to 3-wire current loop interface.

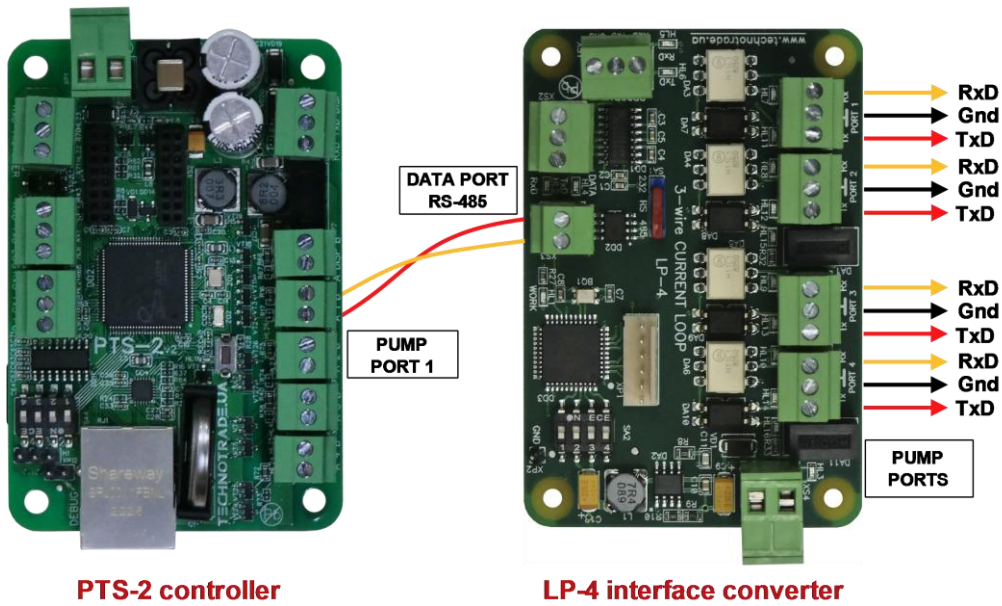

PTS-2 controller

LP-4 interface converter

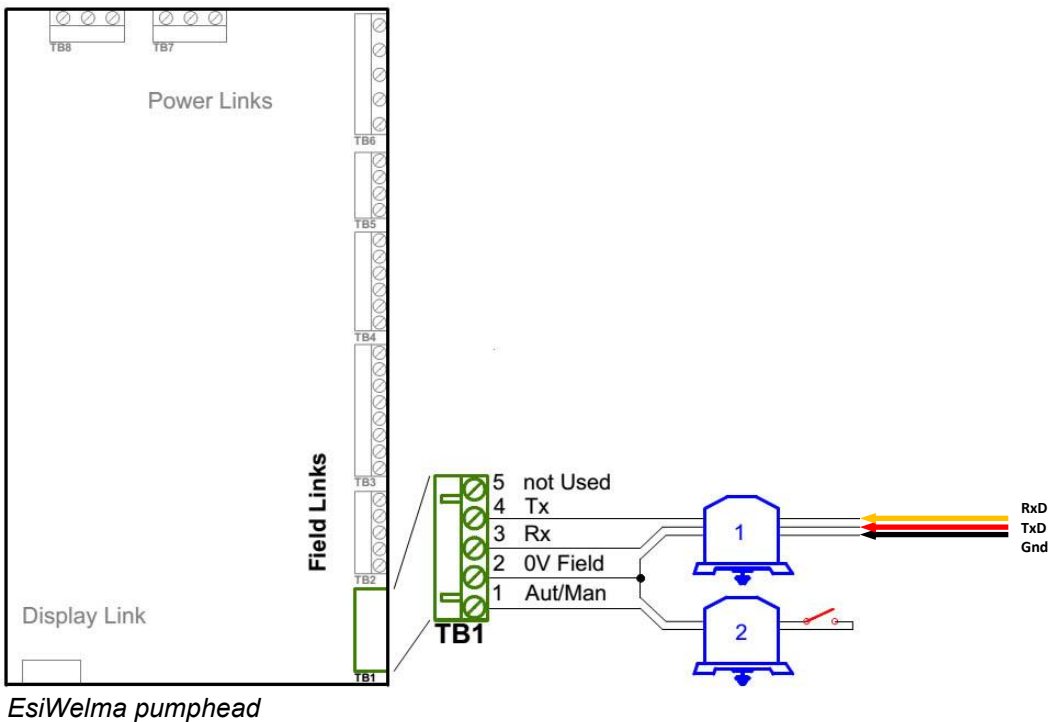

EsiWelma pumphead

Maser dispenser connection scheme

Connection to Maser dispenser is made directly without any interface converter.

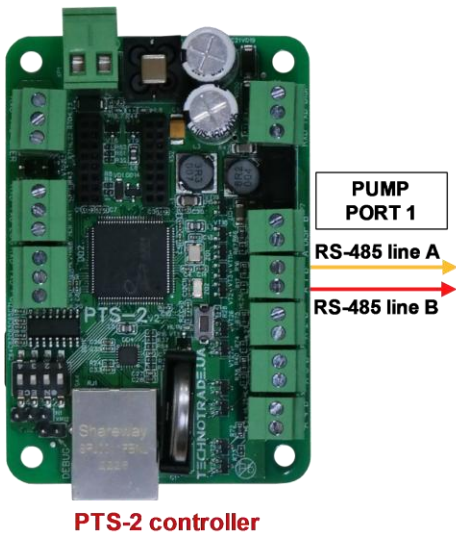

PTS-2 controller

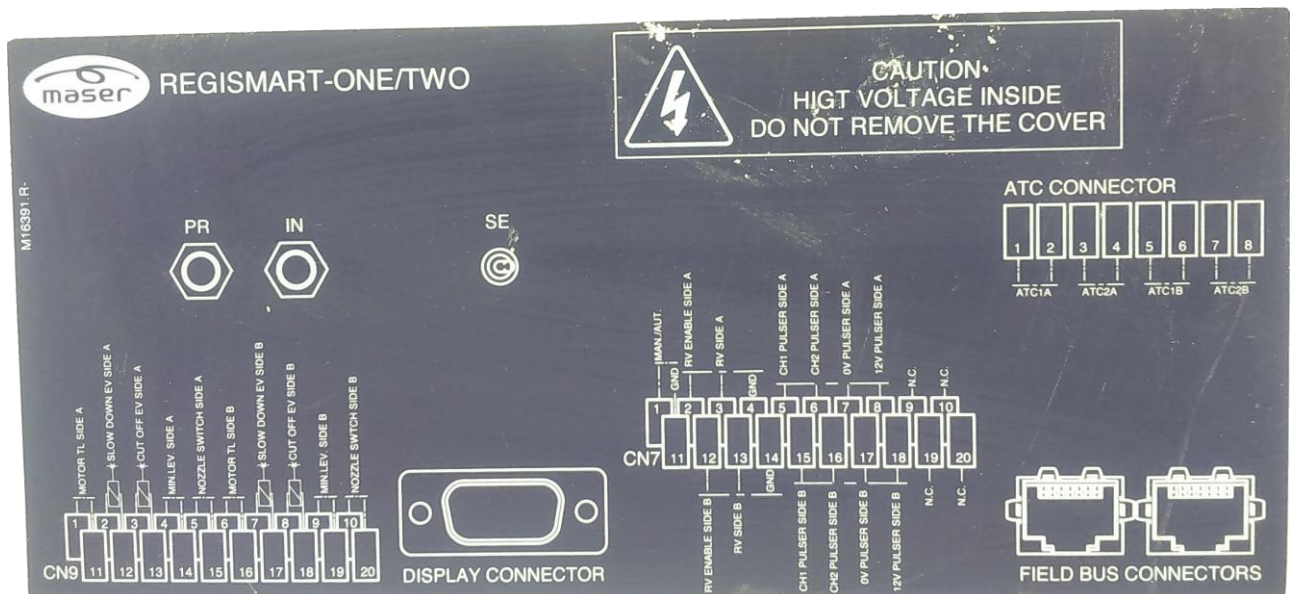

Maser dispenser computer connections label

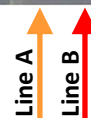

Petposan-S4 / Meksan-S4 / Europump-S4 / Yenen dispensers connection scheme

Connection to S4 computer is made through 2-wire GB interface converter (<https://www.technotrade.ua/gilbarco-interface-converter.html>), which provides connection of RS-232/RS-485 interfaces to 2-wire current loop interface.

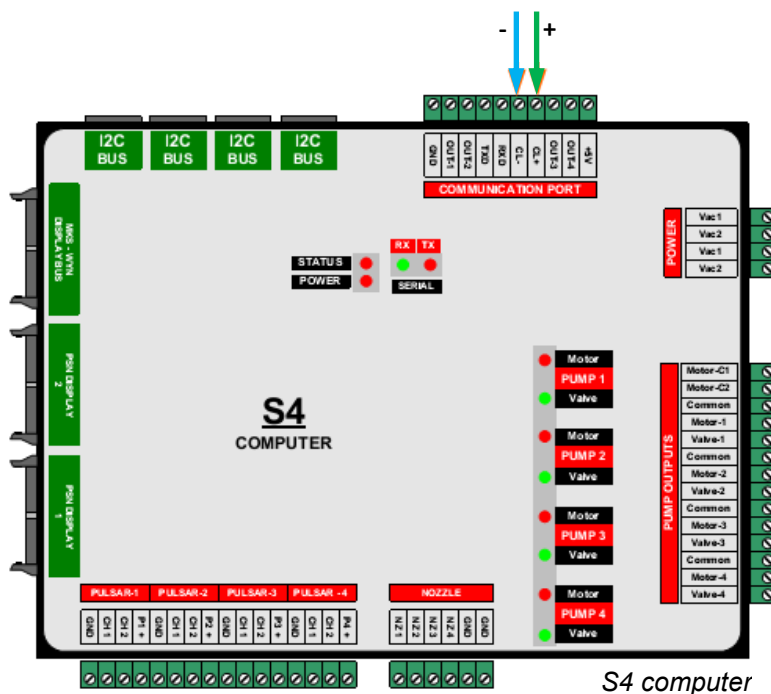
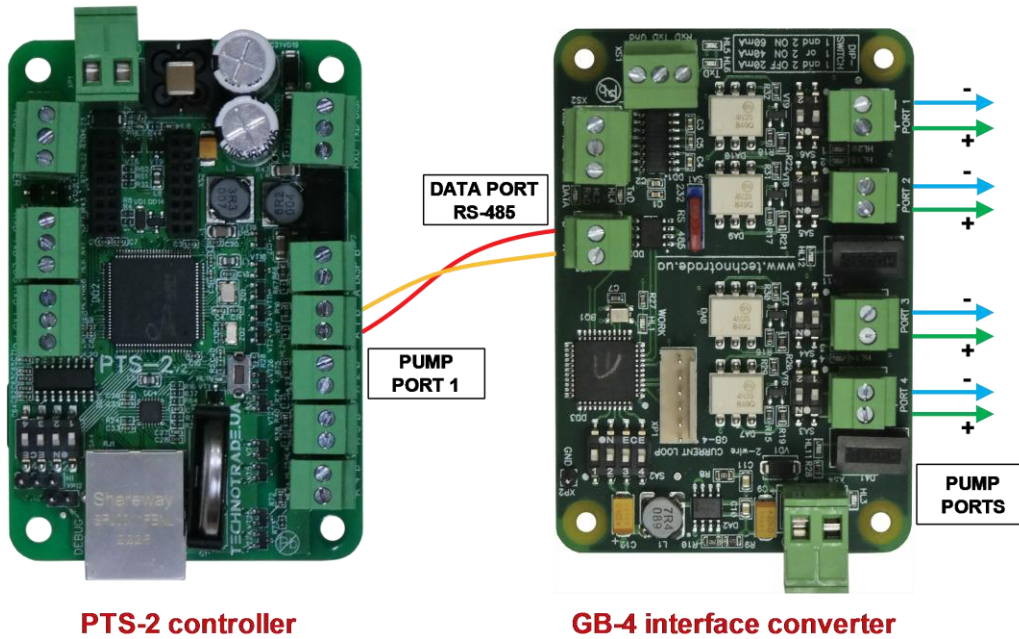

Yenen dispensers connection scheme

Connection to S4s computer is made either directly from the PTS-2 controller using RS-485 interface (no additional interface converter is required) or through 2-wire GB interface converter (<https://www.technotrade.ua/gilbarco-interface-converter.html>), which provides connection of RS-232/RS-485 interfaces to 2-wire current loop interface.

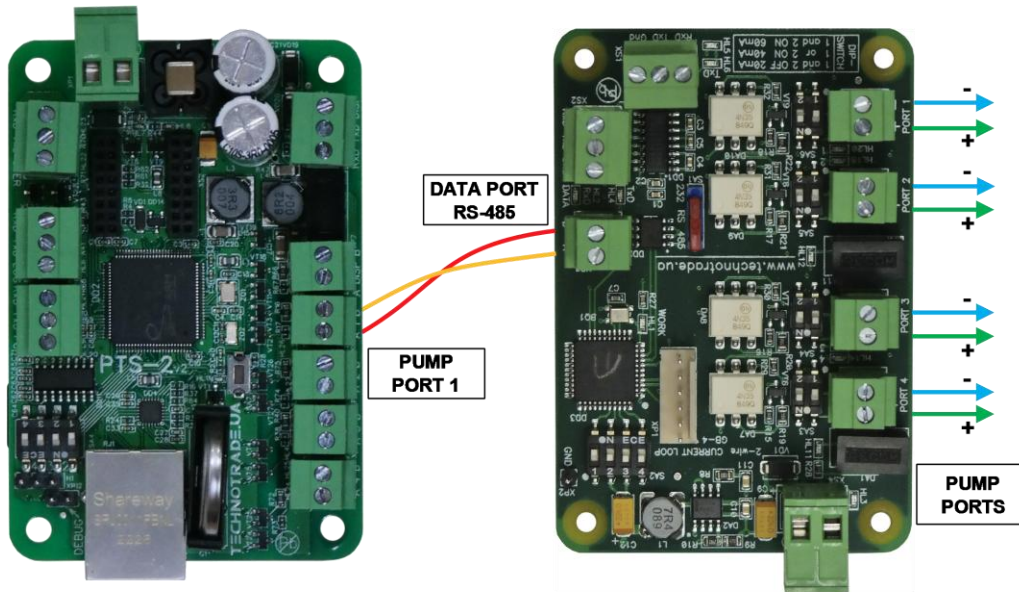

PTS-2 controller

GB-4 interface converter

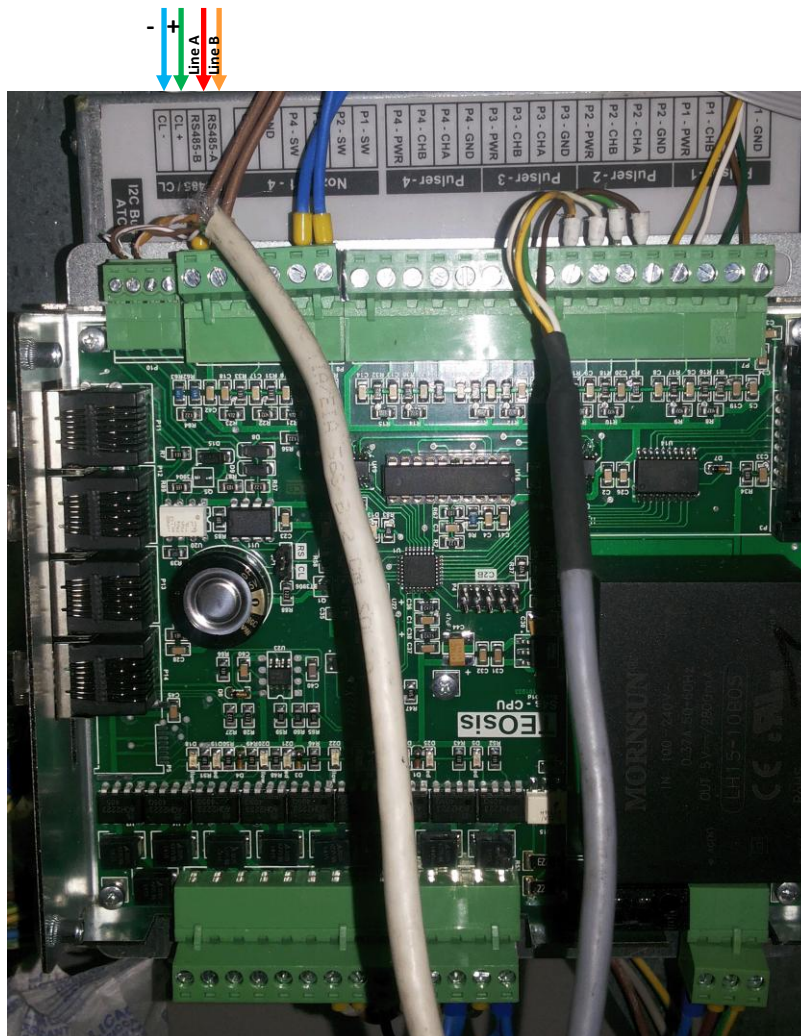

S4s computer

Petposan-Beta / Europump-Beta dispensers connection scheme

Connection to Beta computer is made through 2-wire GB interface converter (<https://www.technotrade.ua/qilbarco-interface-converter.html>), which provides connection of RS-232/RS-485 interfaces to 2-wire current loop interface.

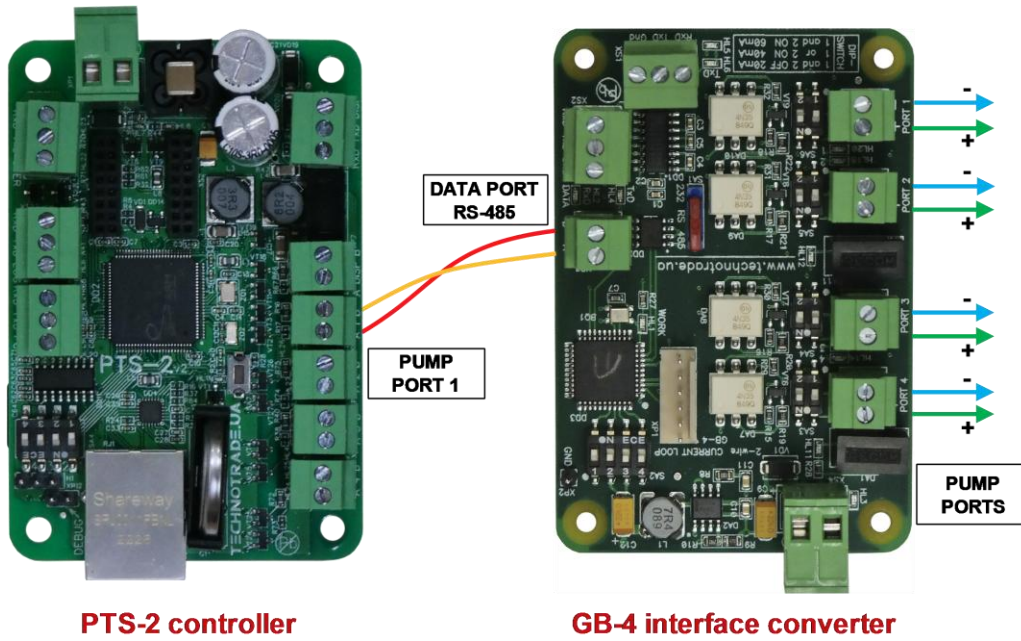

PTS-2 controller

GB-4 interface converter

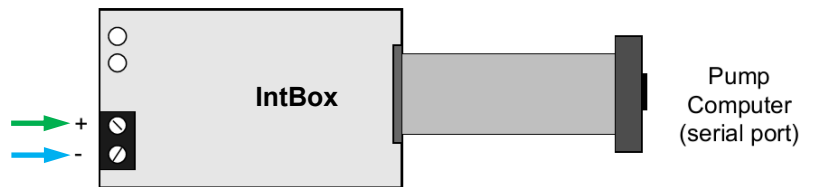

Petposan-Beta CPU

EuroPump dispenser connection scheme

Connection to EuroPump dispenser is made through 2-wire GB interface converter (<https://www.technotrade.ua/qilbarco-interface-converter.html>), which provides connection of RS-232/RS-485 interfaces to 2-wire current loop interface.

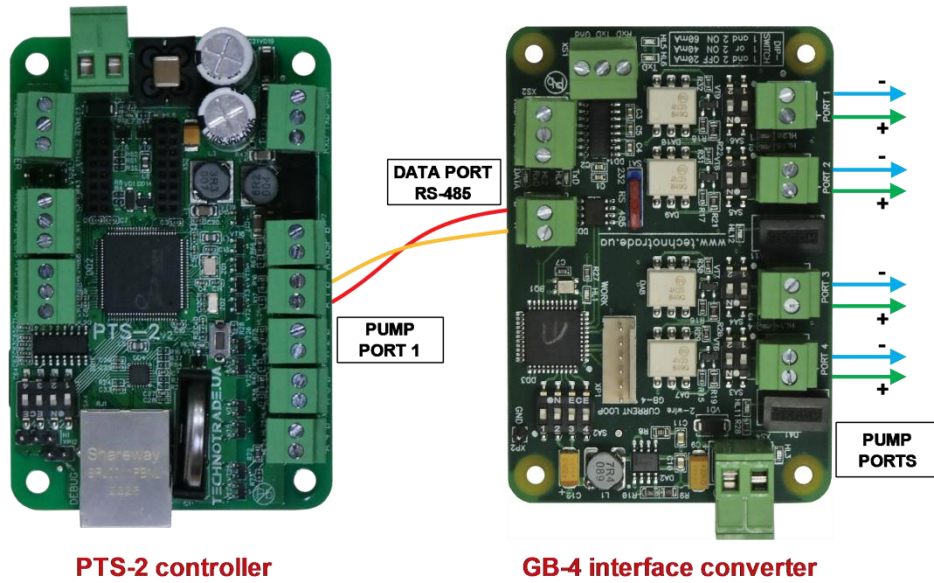

PTS-2 controller

GB-4 interface converter

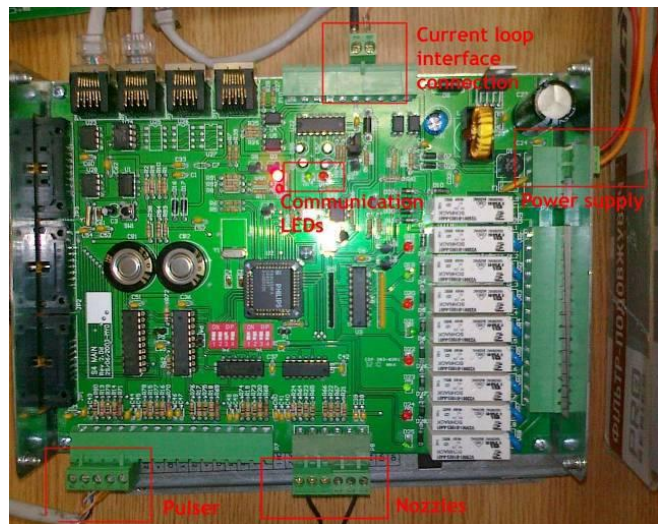

EuroPump dispenser computer

EuroPump EUROSTAR E2-SL dispenser computer

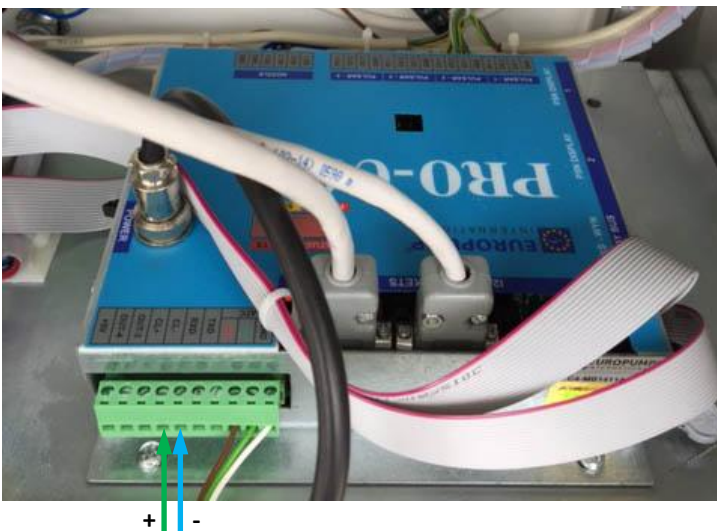

+ -

Mekser dispenser connection scheme

Connection to Mekser dispenser is made through 2-wire GB interface converter (<https://www.technotrade.ua/qilbarco-interface-converter.html>), which provides connection of RS-232/RS-485 interfaces to 2-wire current loop interface.

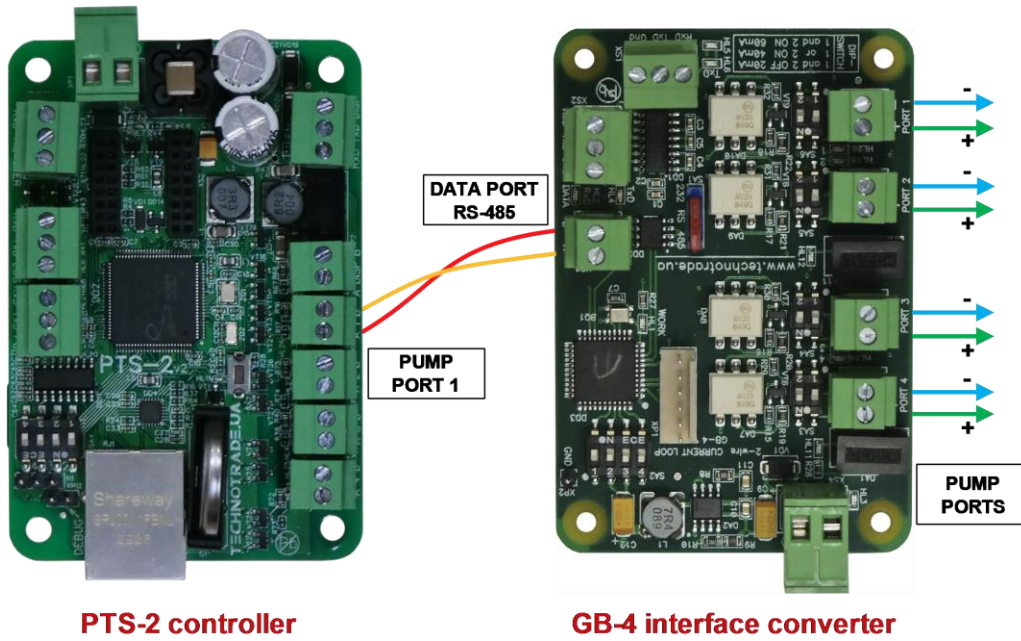

PTS-2 controller

GB-4 interface converter

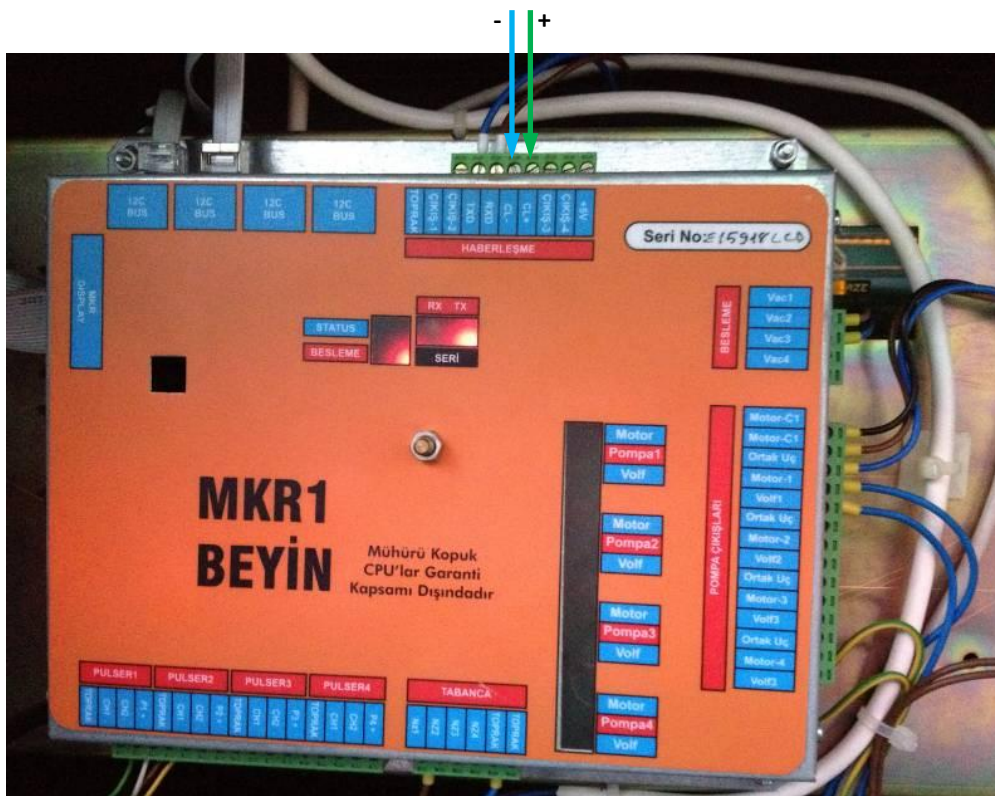

Mekser dispenser board

Fuelsis dispenser connection scheme

Connection to Fuelsis dispenser is made directly without any interface converter.

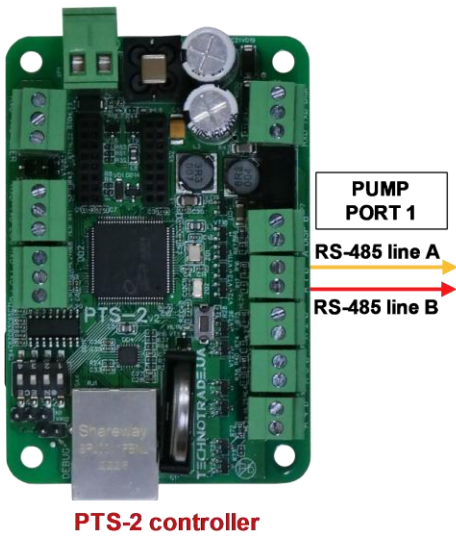

PTS-2 controller

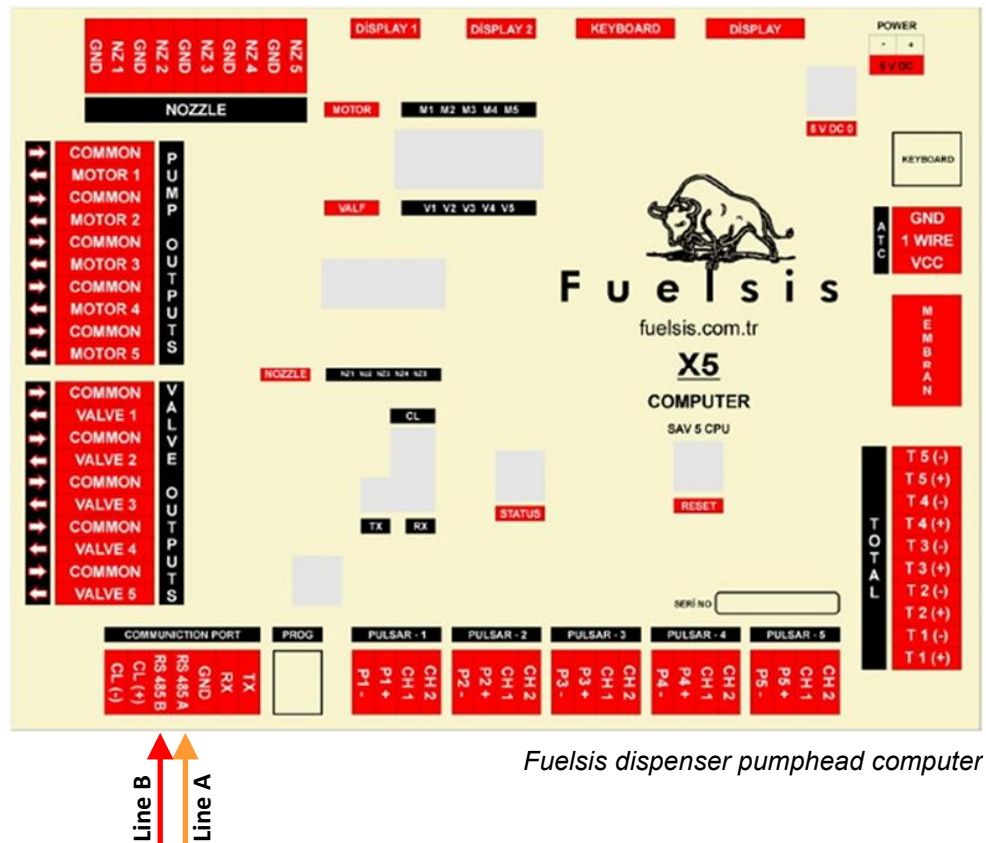

Fuelsis dispenser pumphead computer

Mepsan Unimep dispenser connection scheme

Connection to Mepsan dispenser is made directly without any interface converter.

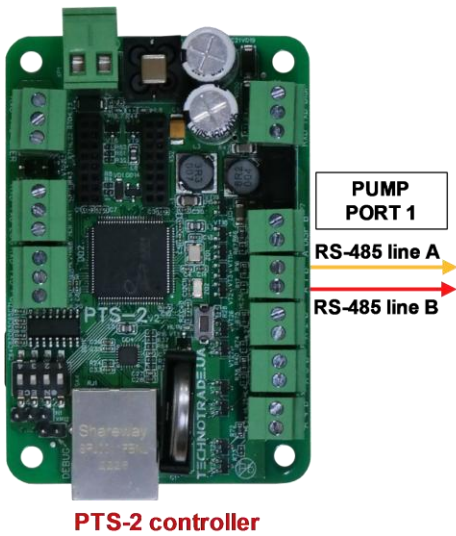

PTS-2 controller

Mepsan Unimep dispenser calculator

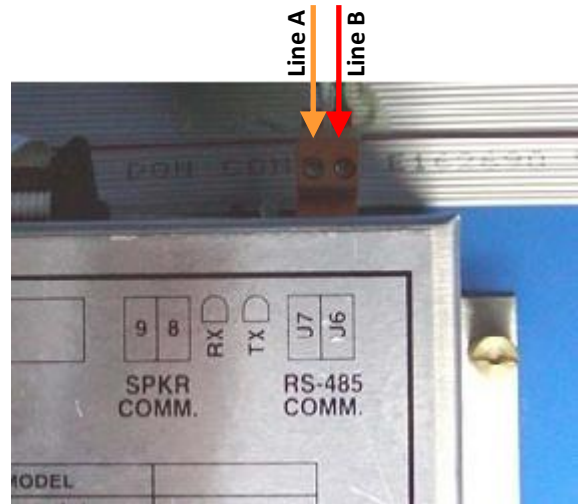
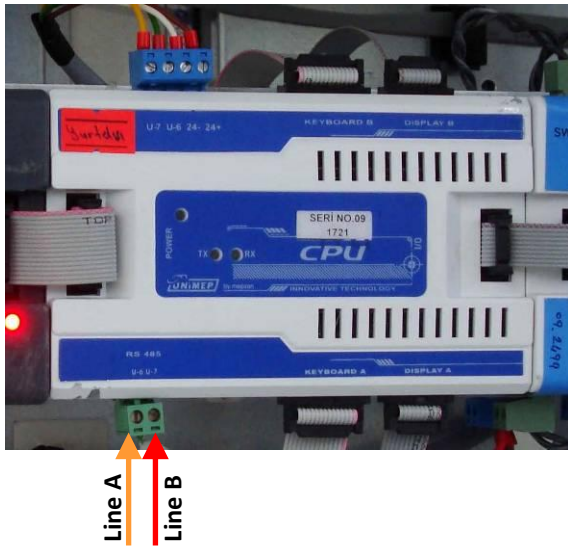

Mepsan Unimep dispenser calculator

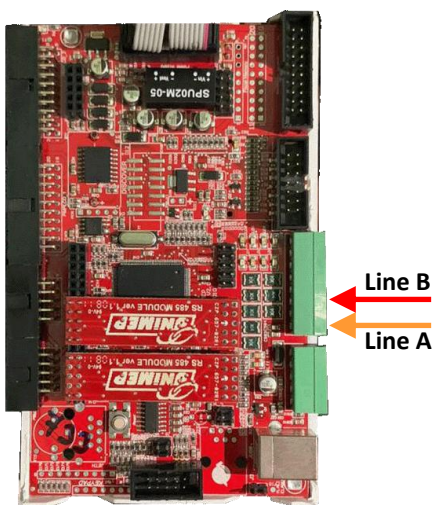

Mepsan dispenser board

Meksan / Wayne SU86 dispenser connection scheme

Connection to Meksan / Wayne SU86 dispenser is made directly without any interface converter.

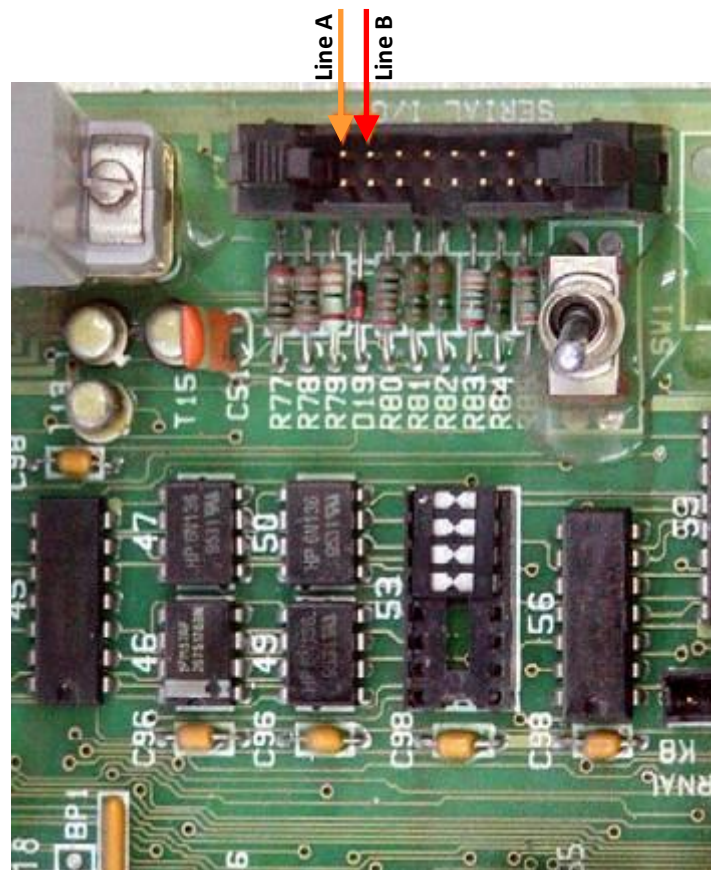
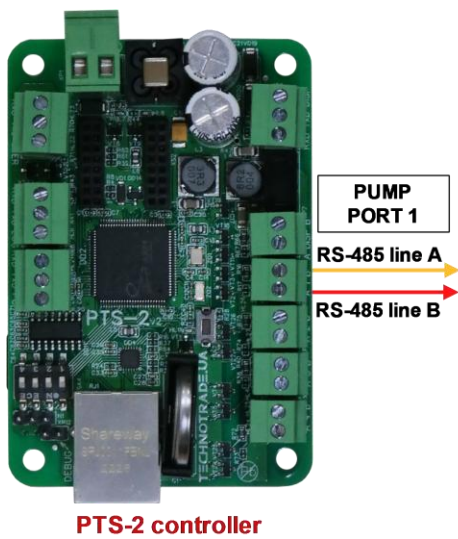

MEKSAN / WAYNE SU86 dispenser board

Baransay dispenser connection scheme

Connection to Baransay dispenser is made directly without any interface converter.

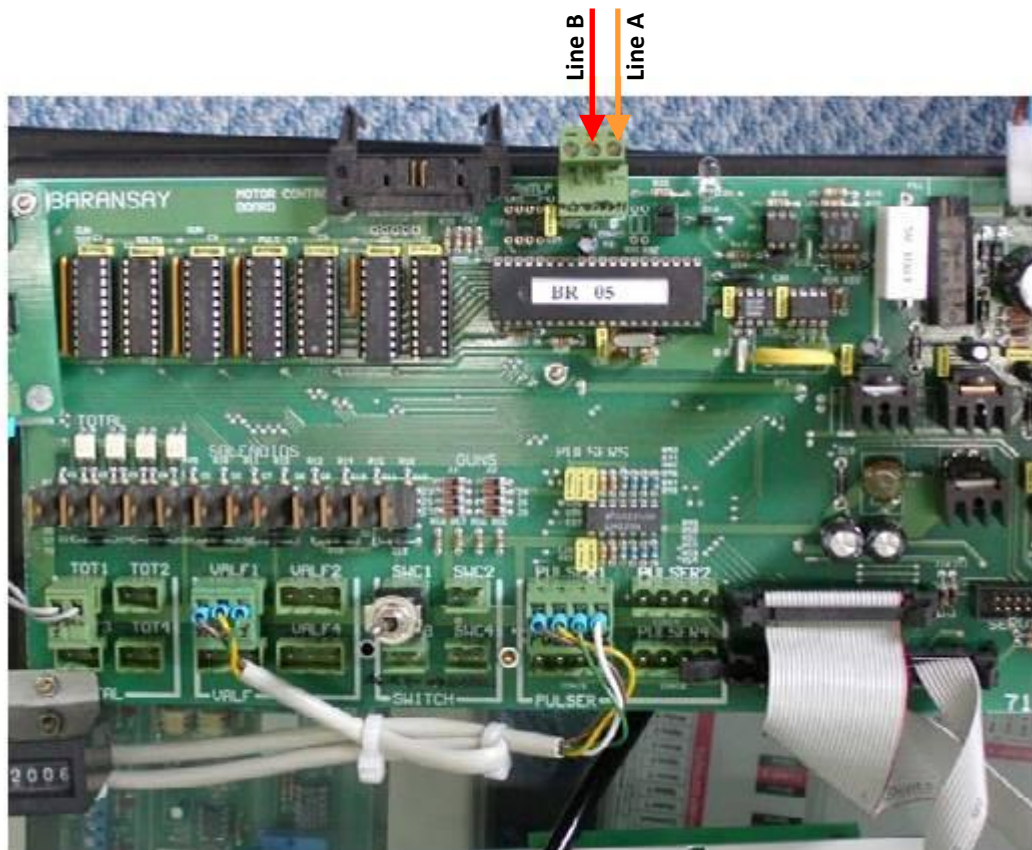
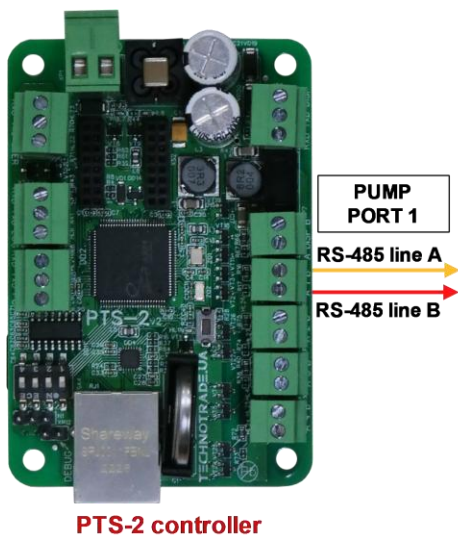

Baransay dispenser board

Durulsan dispenser connection scheme

Connection to Durulsan dispenser is made directly without any interface converter.

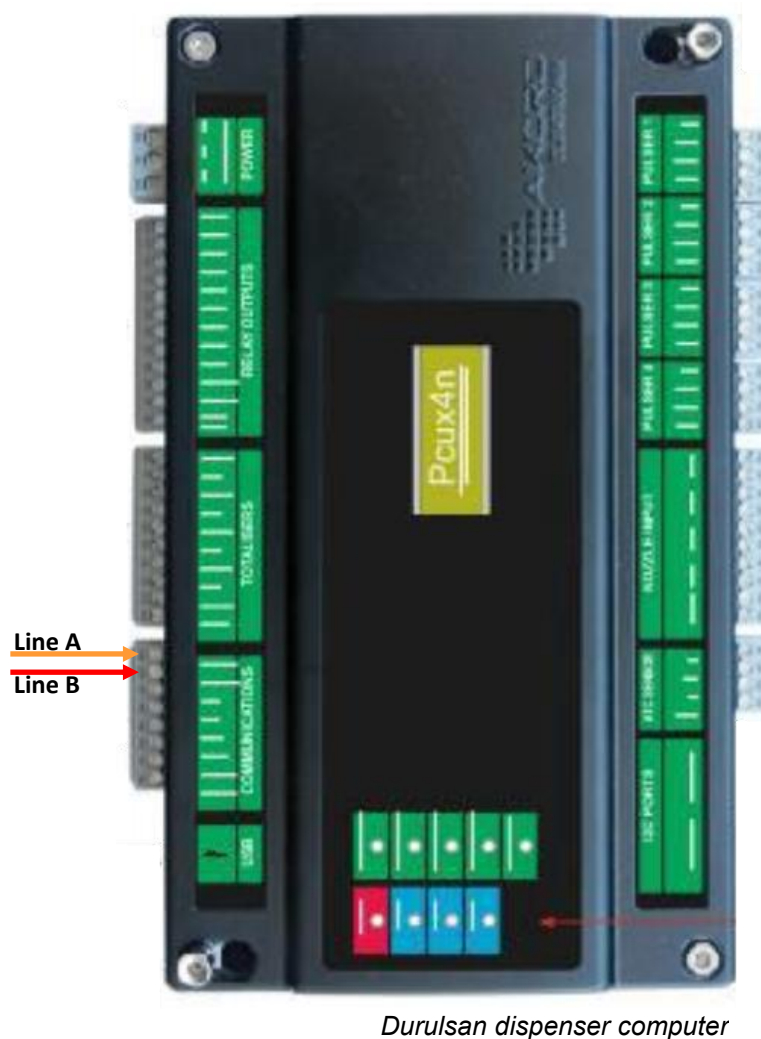
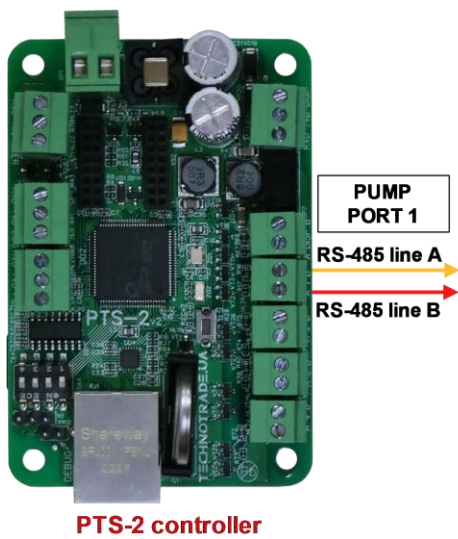

2A LPG dispenser connection scheme

Connection to 2A dispenser is made directly without any interface converter.

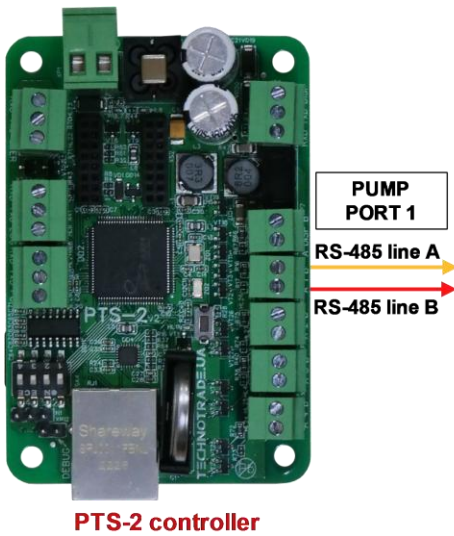

PTS-2 controller



2A dispenser computer

Falcon dispenser connection scheme

Connection to Falcon dispenser is made through 2-wire GB interface converter (<https://www.technotrade.ua/gilbarco-interface-converter.html>), which provides connection of RS-232/RS-485 interfaces to 2-wire current loop interface.



PTS-2 controller

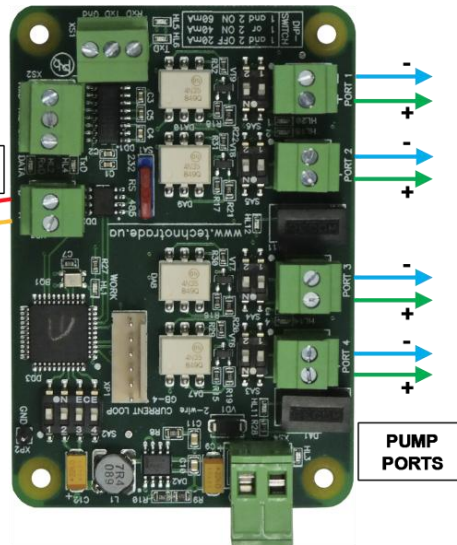
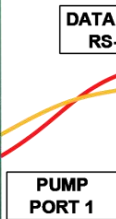

GB-4 interface converter

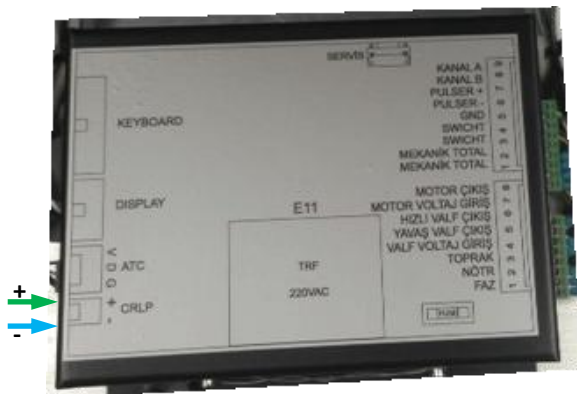

Falcon dispenser computer E11



Falcon dispenser computer E22

Tiger dispenser connection scheme

Connection to Tiger dispenser is made directly without any interface converter.

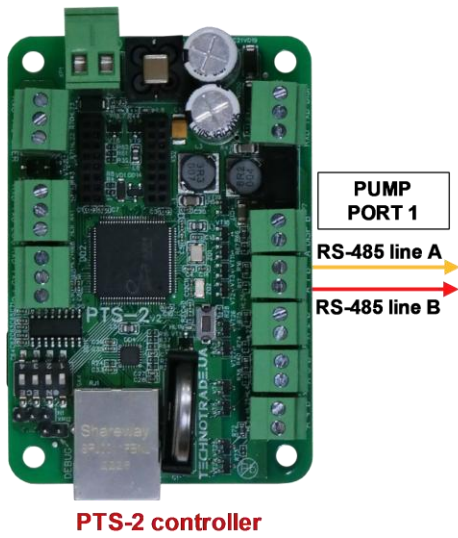

PTS-2 controller

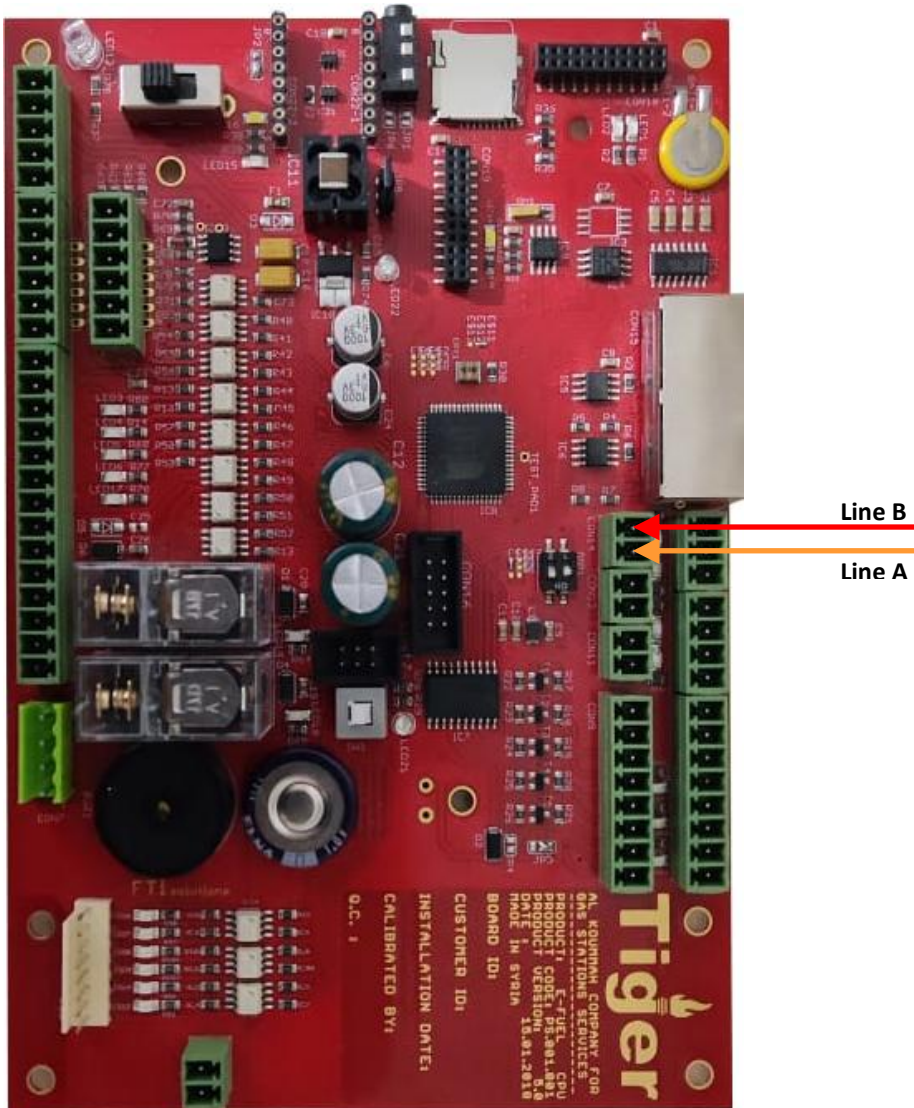

Tiger dispenser mainboard

Korea EnE (LG EnE) dispenser connection scheme

Connection to Korea EnE (LG EnE) dispenser is made directly without any interface converter.

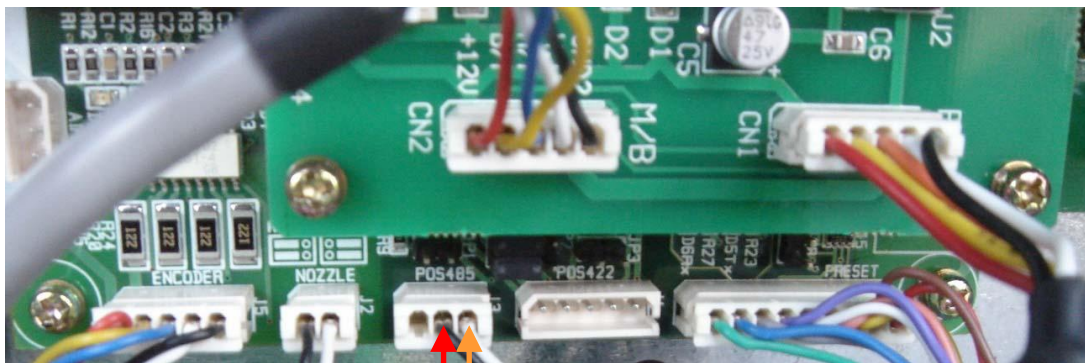
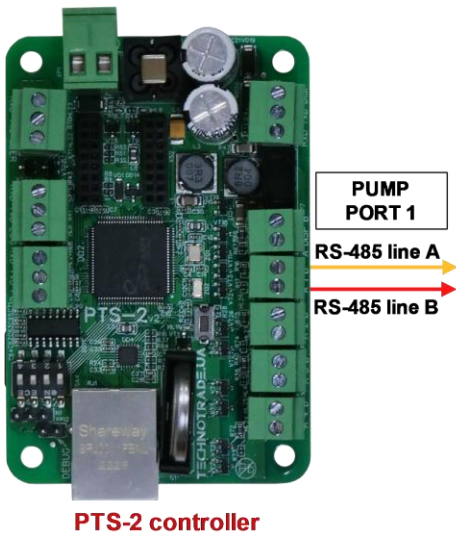

Korea EnE / LG EnE dispenser board

Line B
Line A

Dong Hwa Prime dispenser connection scheme

Connection to Dong Hwa dispenser is made directly without any interface converter.

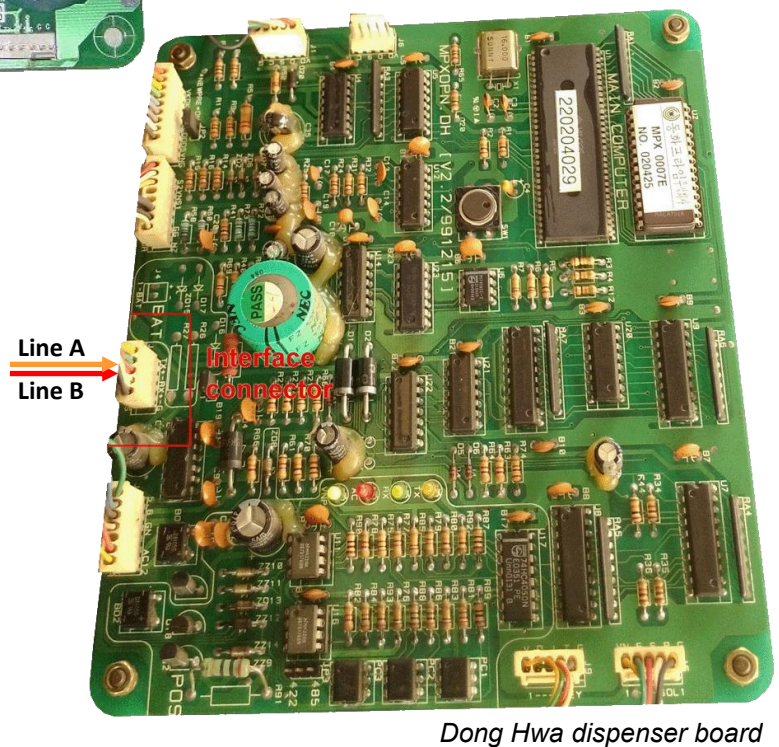
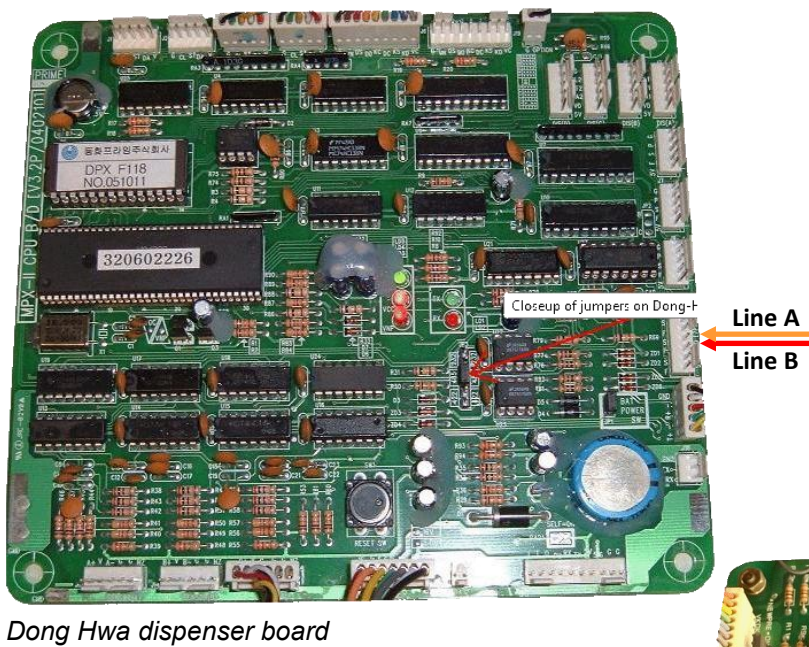
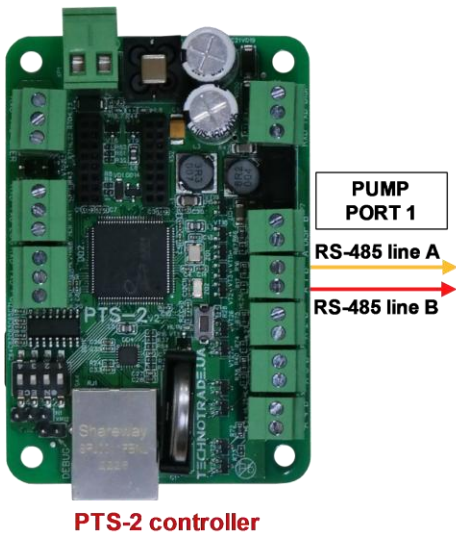

Gallagher (PEC) dispenser connection scheme

Connection to PEC dispenser is made through 2-wire NZ interface converter (<https://technotrade.kiev.ua/compac-interface-converter.html>), which provides connection of RS-232/RS-485 interfaces to 2-wire current loop interface.

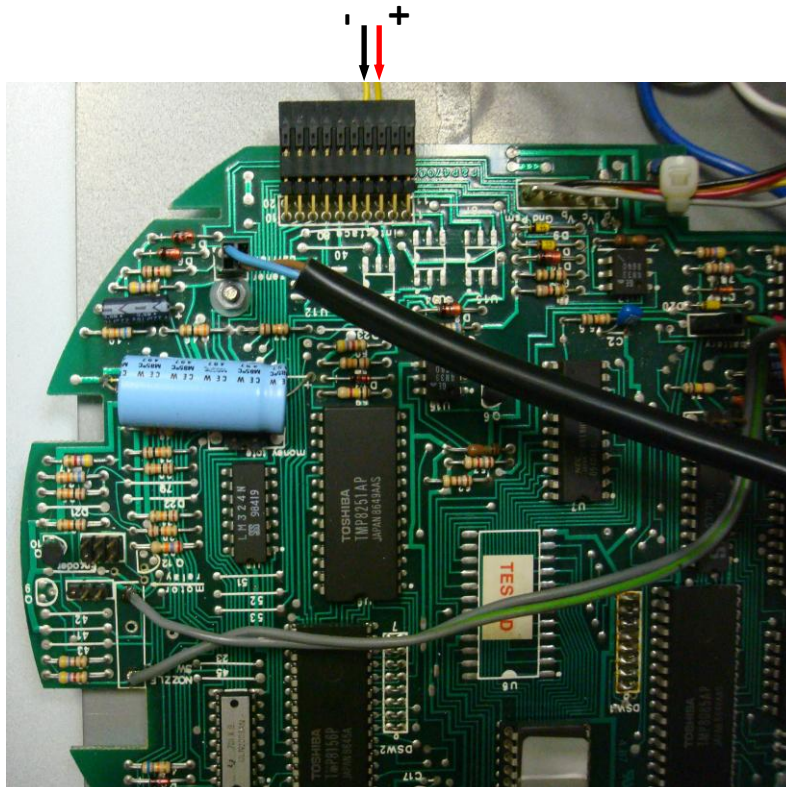
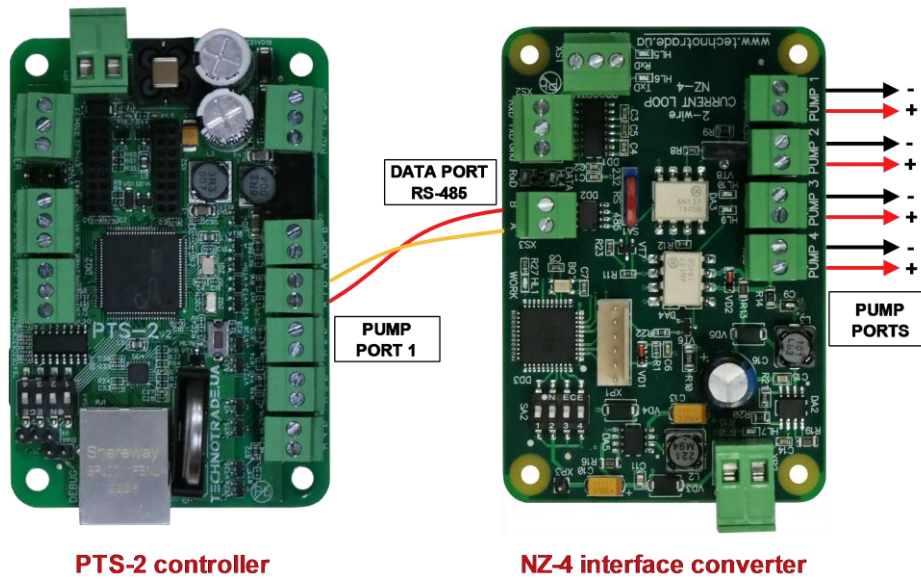

Retron 80 dispenser board connection

Compac dispenser connection scheme

Connection to Compac dispenser is made through 2-wire NZ interface converter (<https://technotrade.kiev.ua/compac-interface-converter.html>), which provides connection of RS-232/RS-485 interfaces to 2-wire current loop interface.

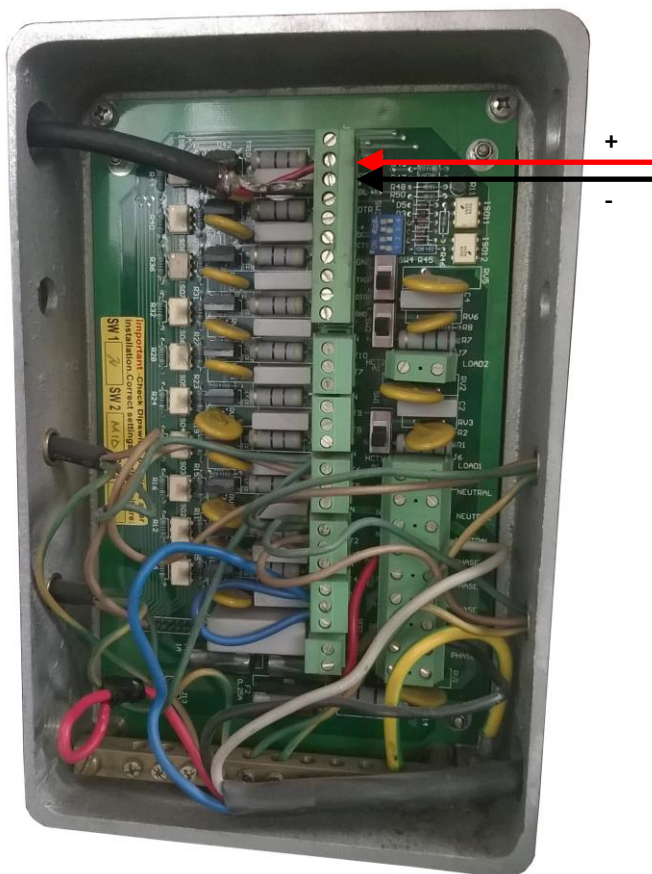
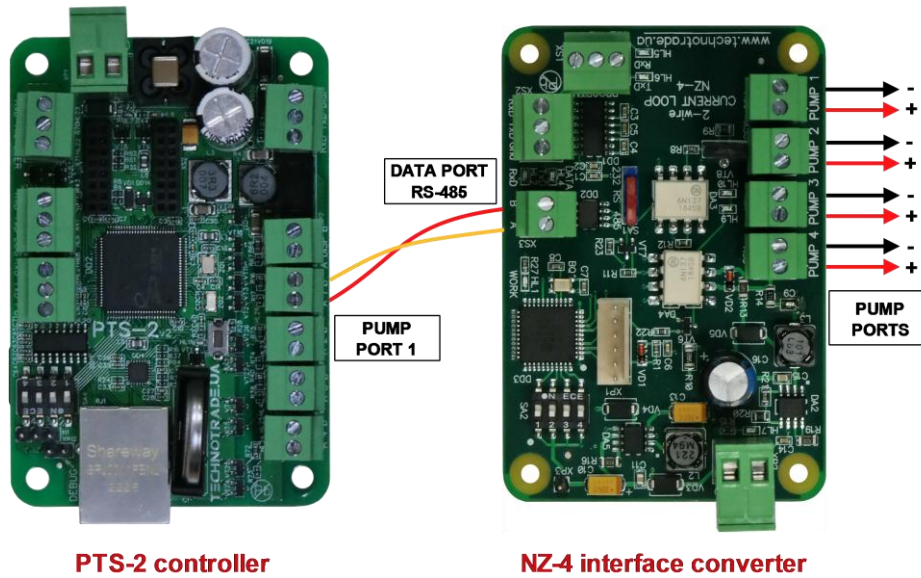

Compac dispenser junction box

Safe dispenser connection scheme

Connection to SAFE dispenser is made directly without any interface converter.

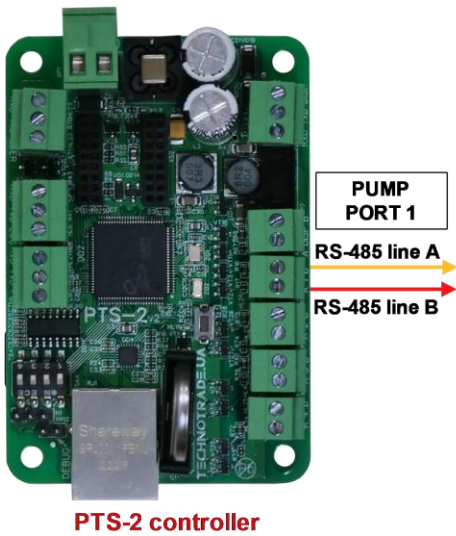

PTS-2 controller

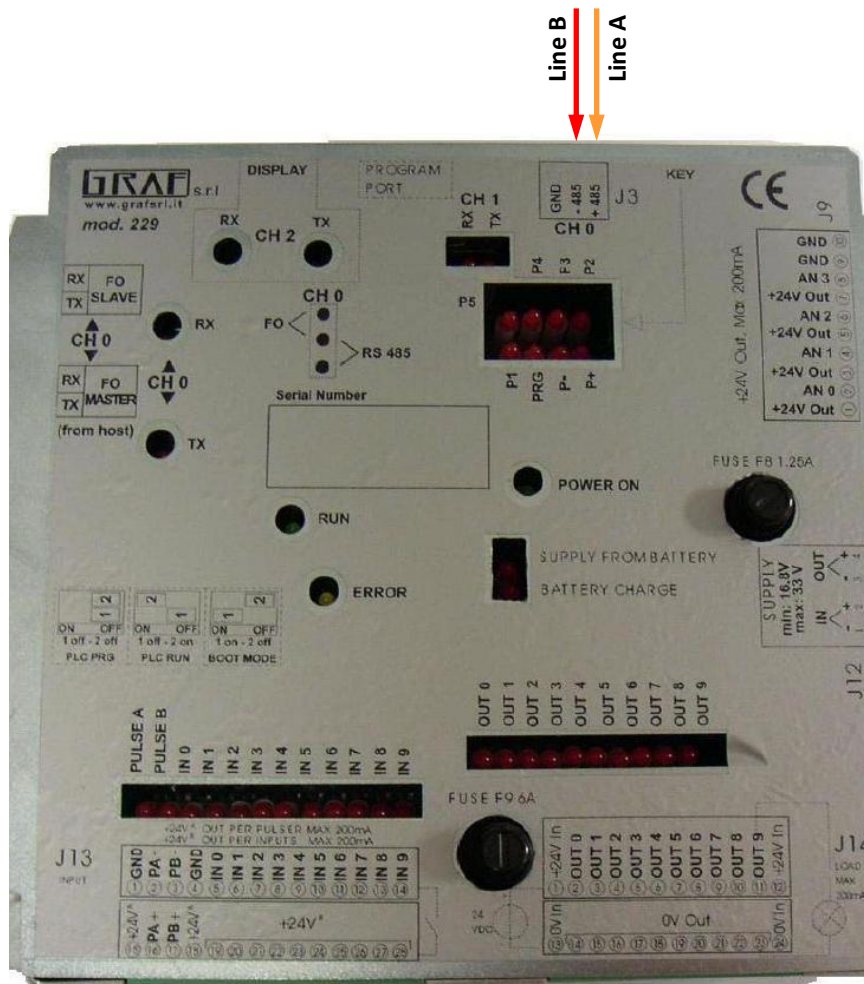

SAFE Graf electronic head PMII

MS Gas dispenser connection scheme

Connection to MS GAS dispenser is made directly without any interface converter.

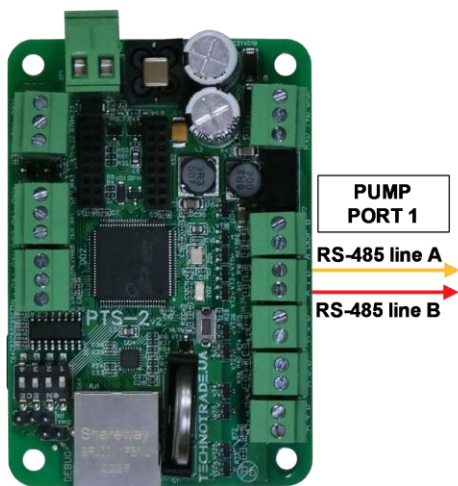

PTS-2 controller

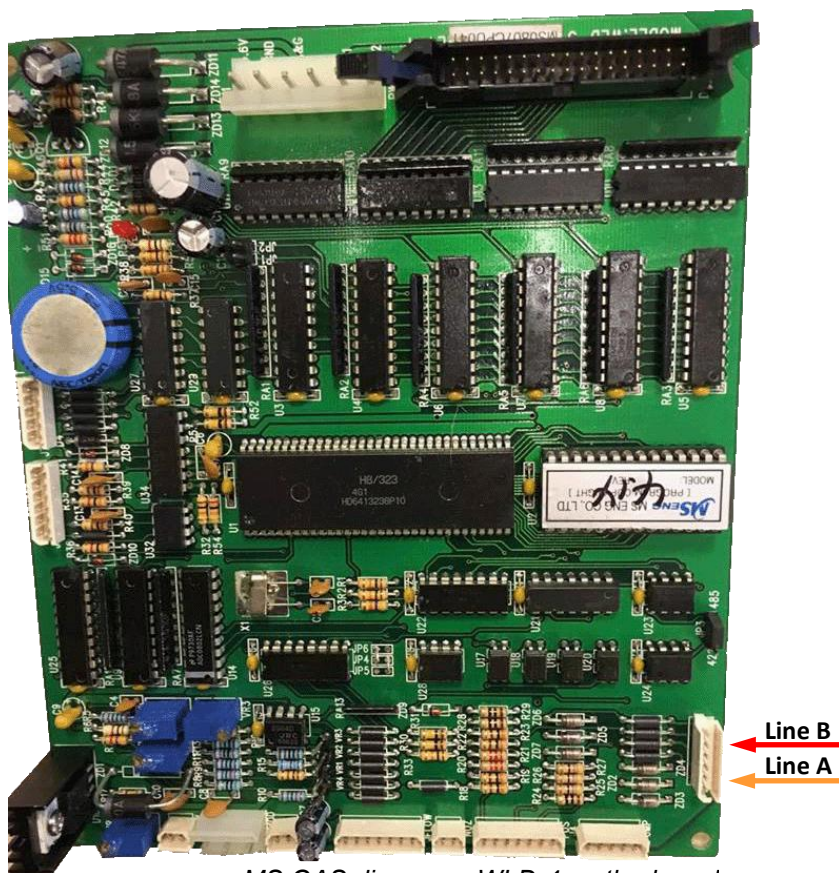

MS GAS dispenser WLD-4 motherboard

Shibata dispenser connection scheme

Connection to SHIBATA dispenser is made directly without any interface converter.

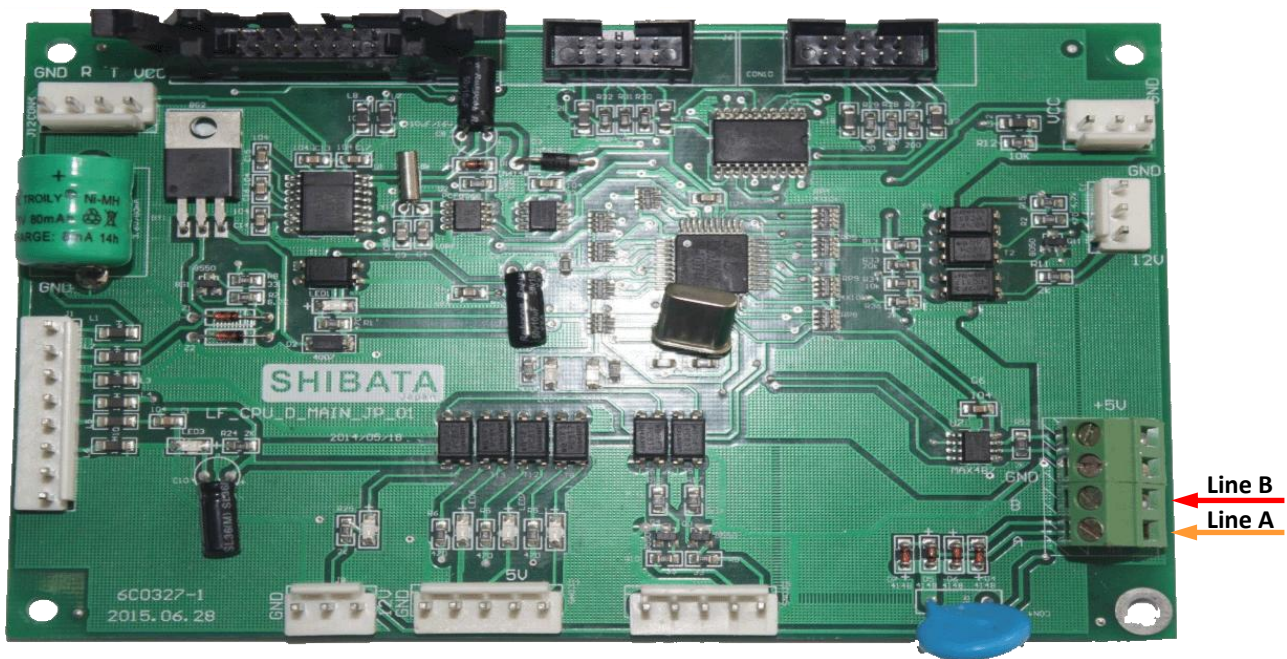
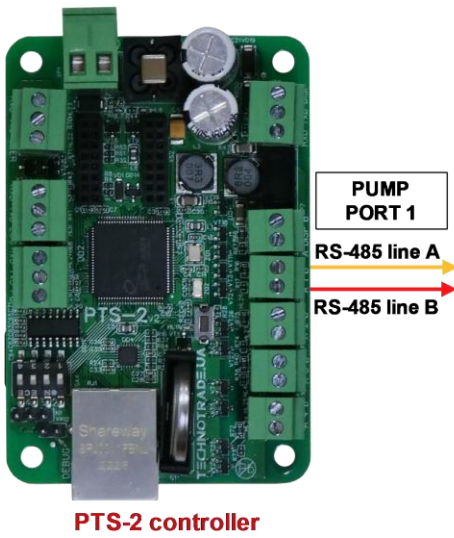

SHIBATA dispenser motherboard

Aspro Develco dispenser connection scheme

Connection to Aspro Develco dispenser is made directly without any interface converter.

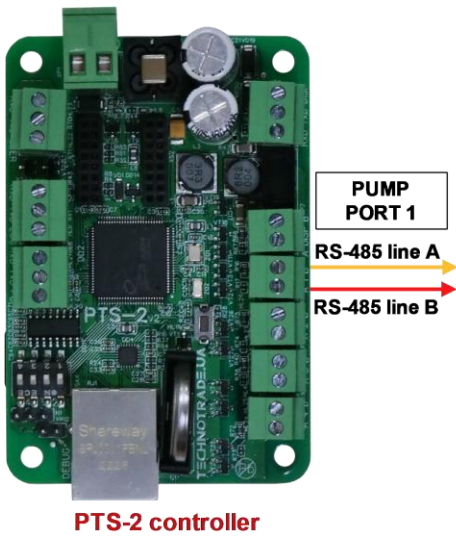

PTS-2 controller

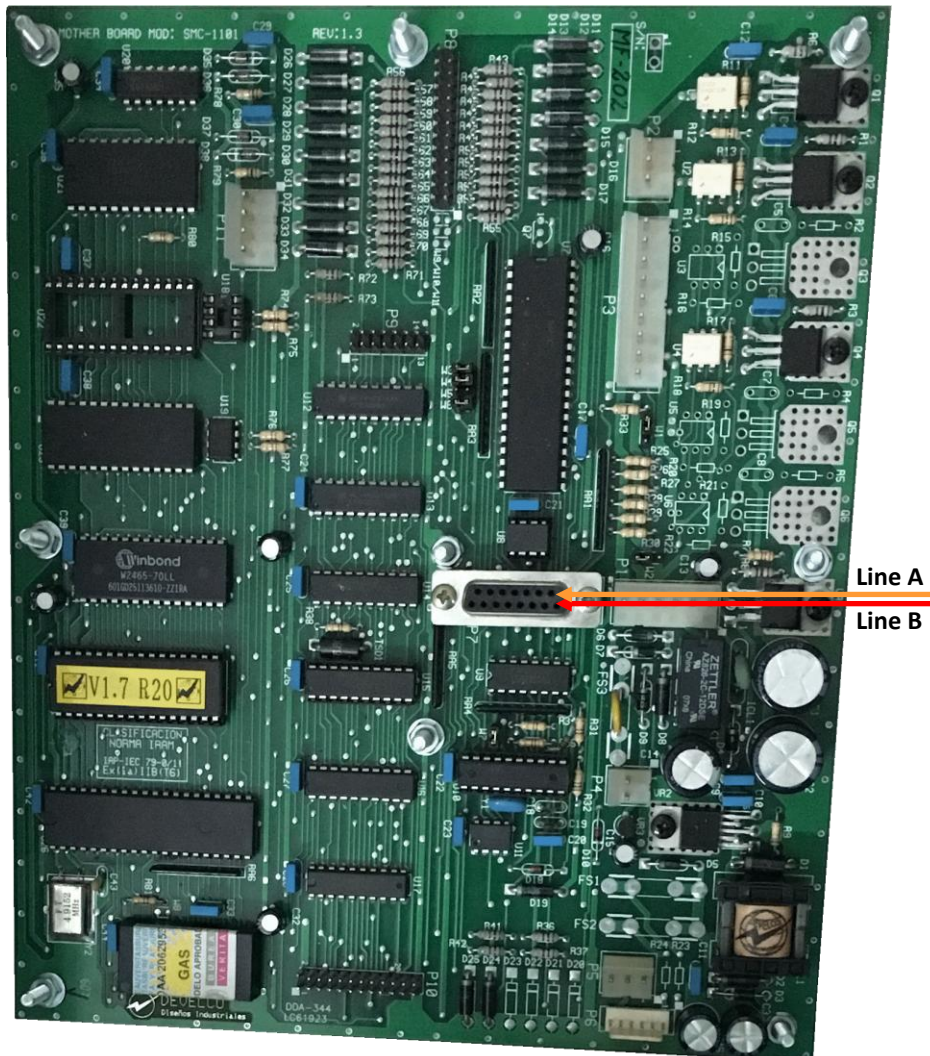

Develco dispenser motherboard

HongYang dispenser connection scheme

Connection to HongYang dispenser is made through 4-wire HY interface converter (<https://www.technotrade.ua/hongyang-interface-converter.html>), which provides connection of RS-232/RS-485 interfaces to 4-wire current loop interface.

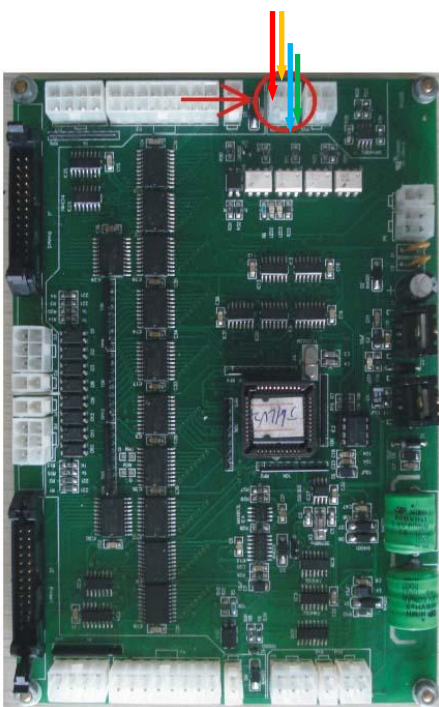
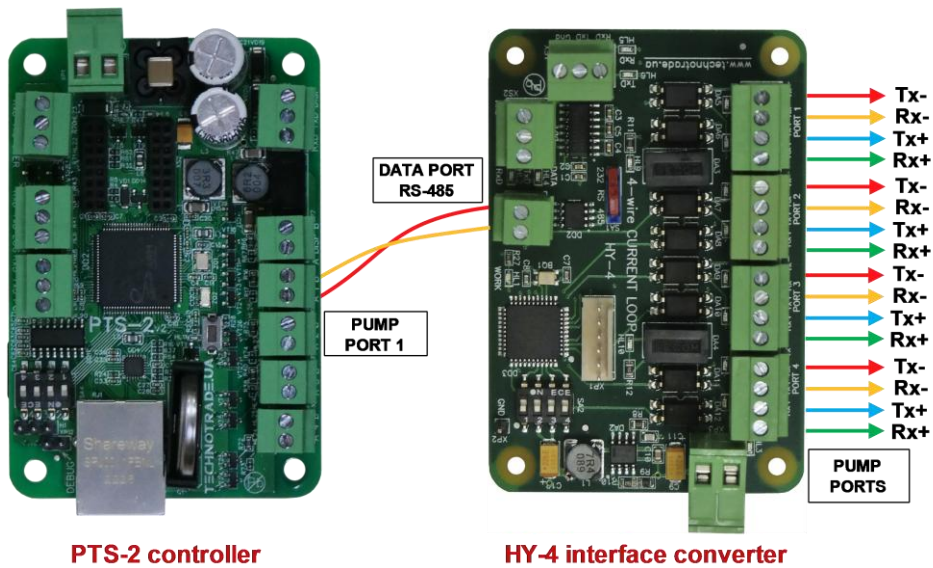

HongYang dispenser boards

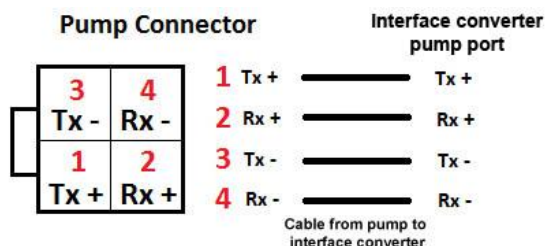

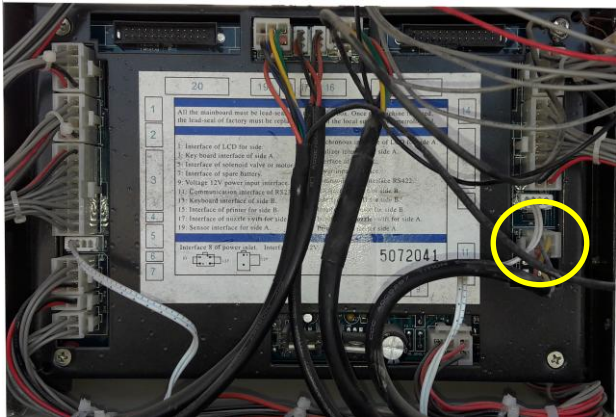

HongYang dispenser calculator

HongYang dispenser calculator

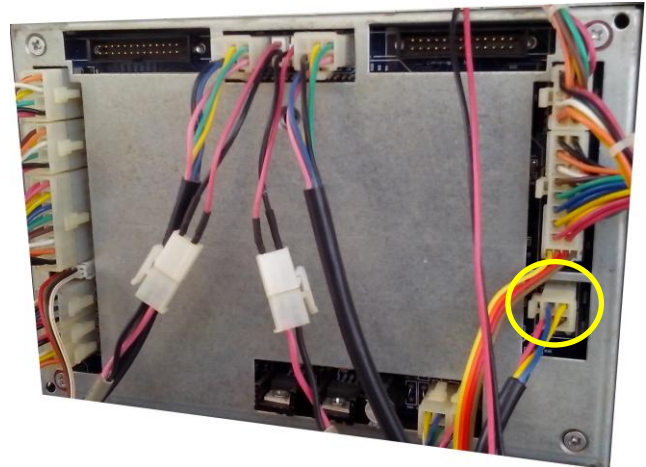

Pump Connector

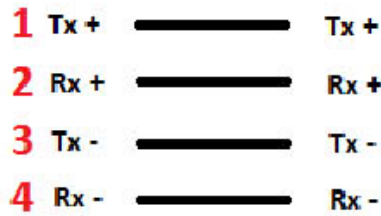
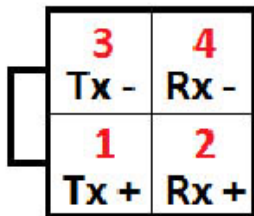

Cable from pump to interface converter

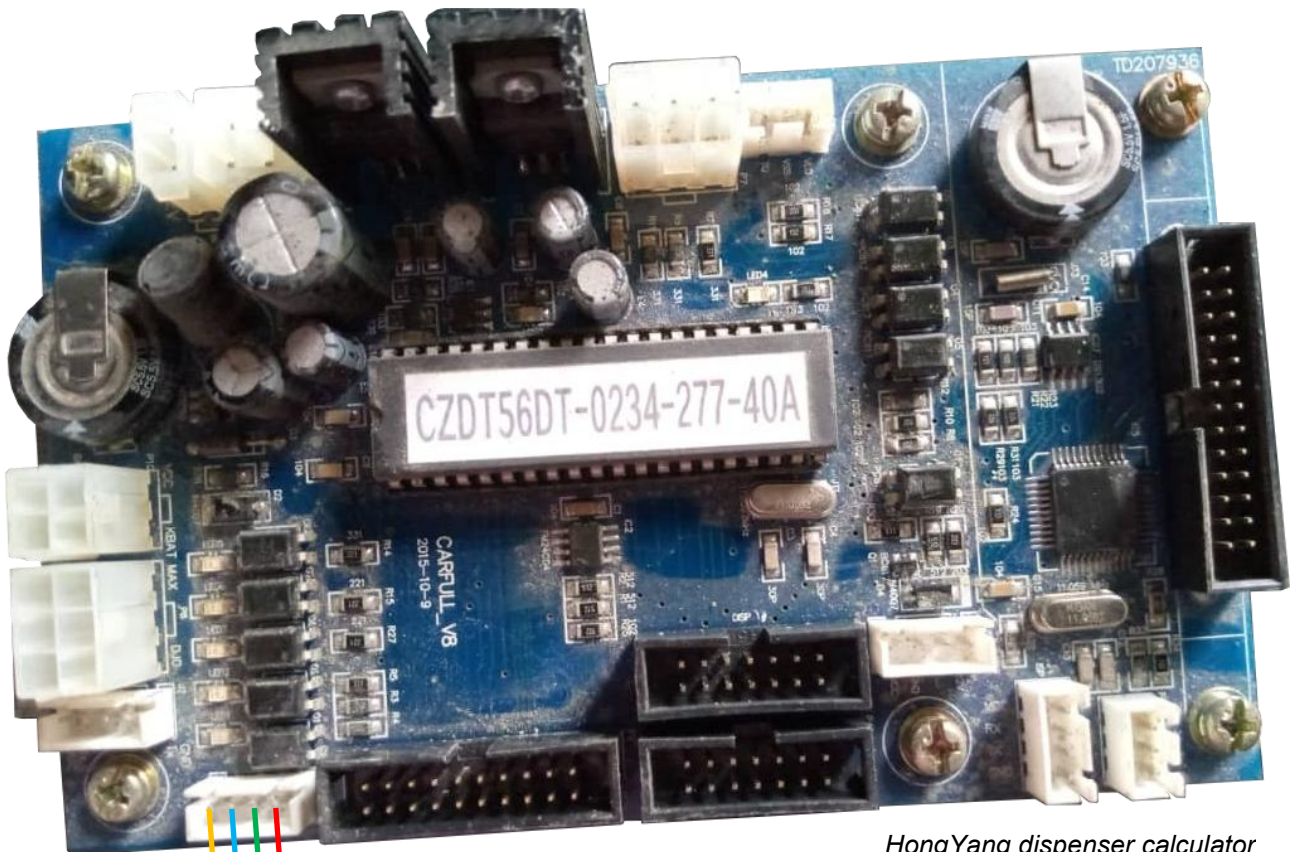

HongYang dispenser calculator



Lanfeng dispenser connection scheme

Connection to Lanfeng dispenser can be made either directly using RS-485 interface.

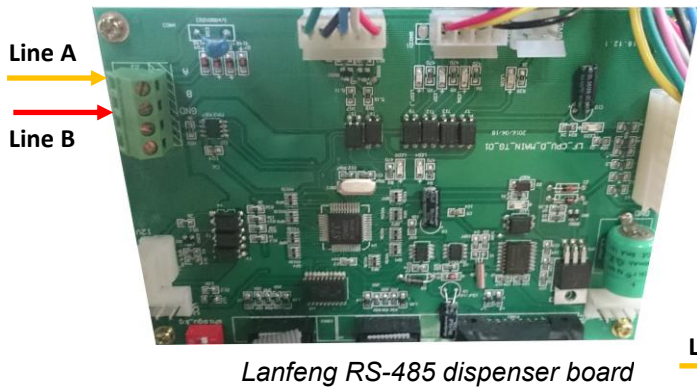
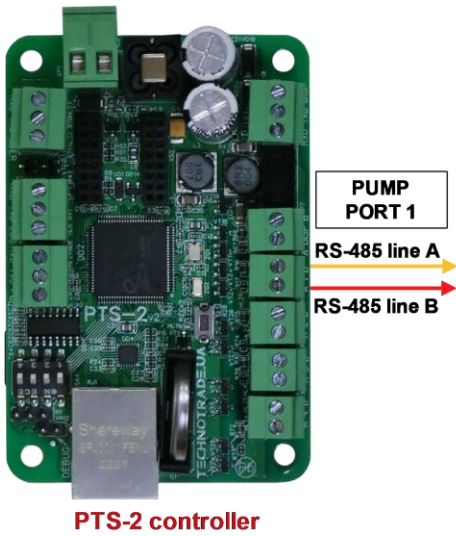

Sanki dispenser connection scheme

Connection to Sanki dispenser is made directly without any interface converter.

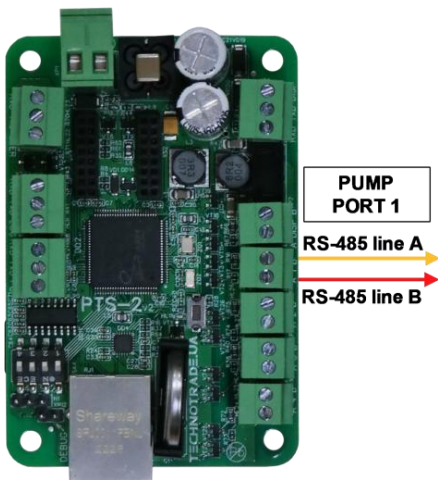

PTS-2 controller

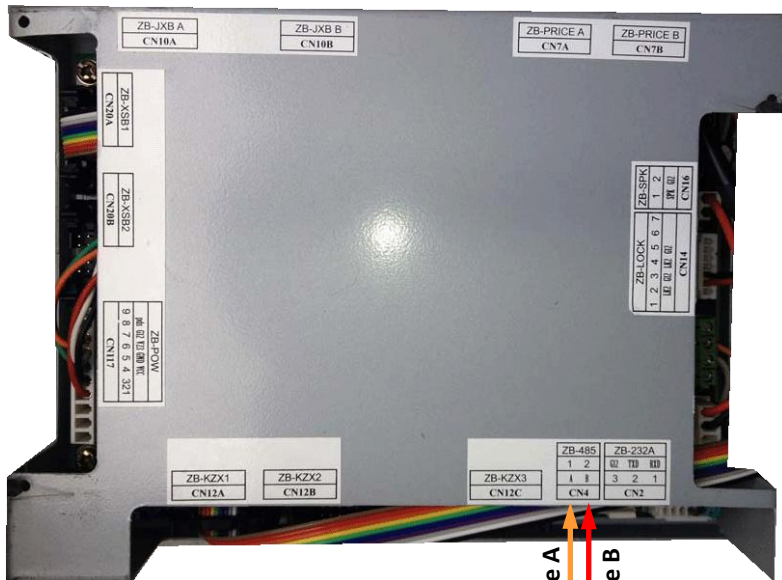

Sanki dispenser board

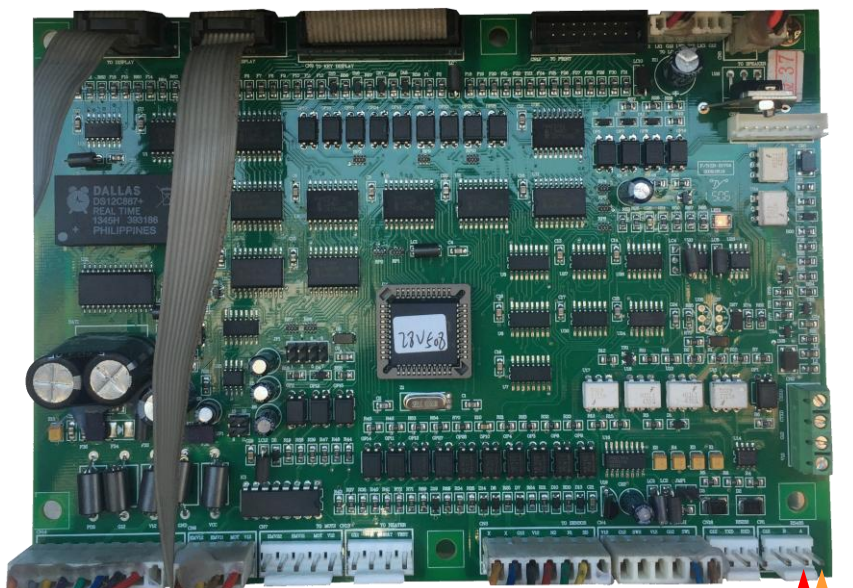

Sanki dispenser board

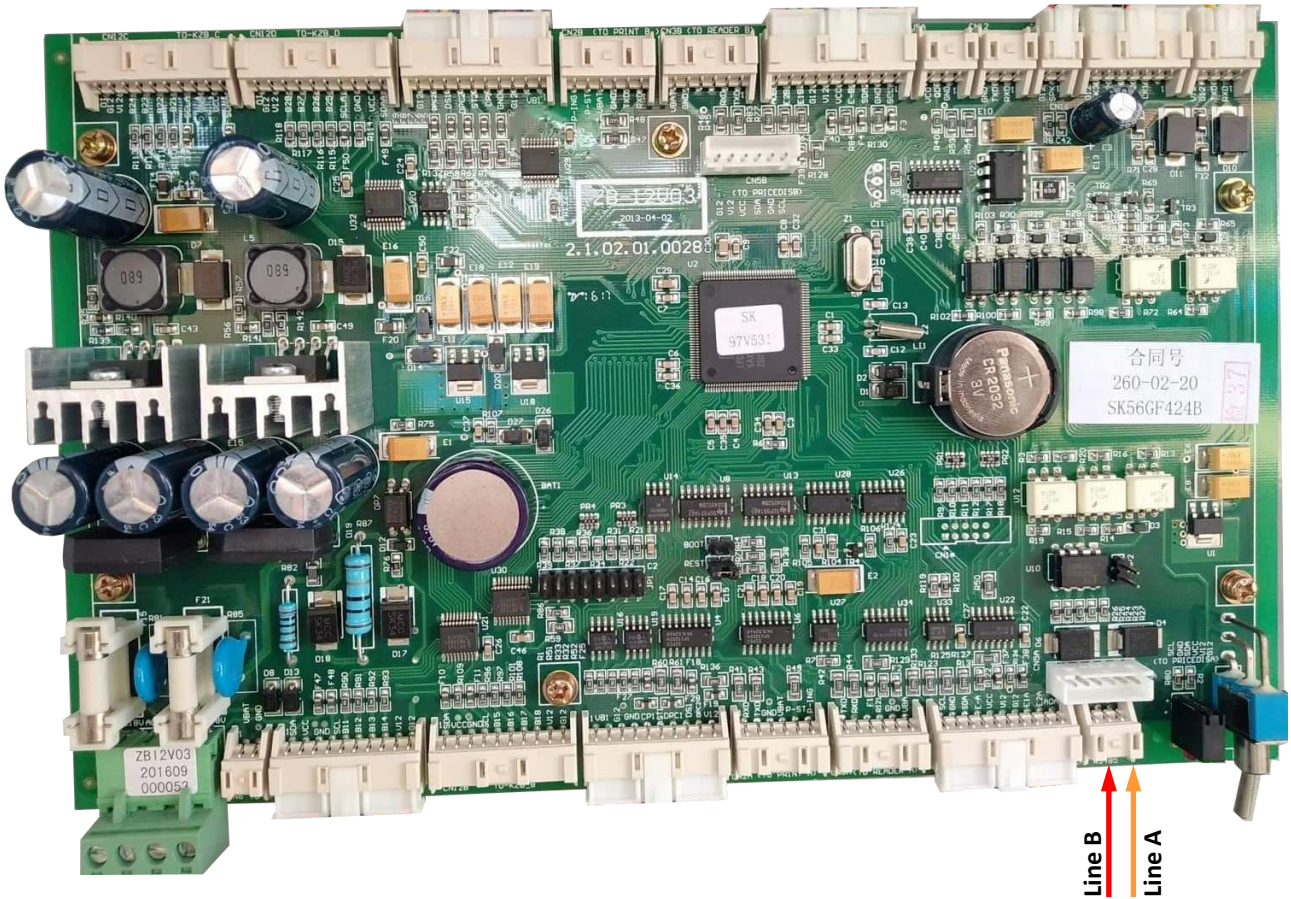

Sanki dispenser I2 board

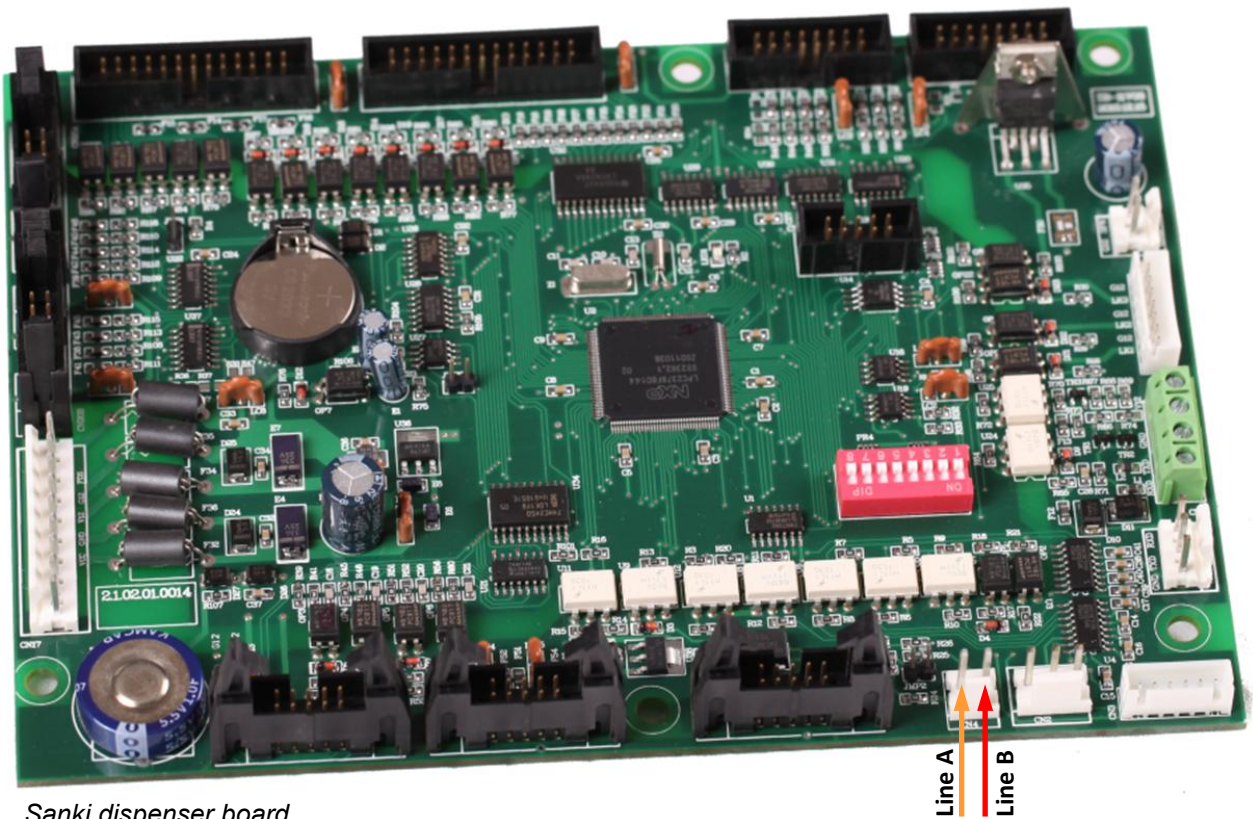

Sanki dispenser board

Datian Machines dispenser connection scheme

Connection to Datian Machines dispenser is made directly without any interface converter.

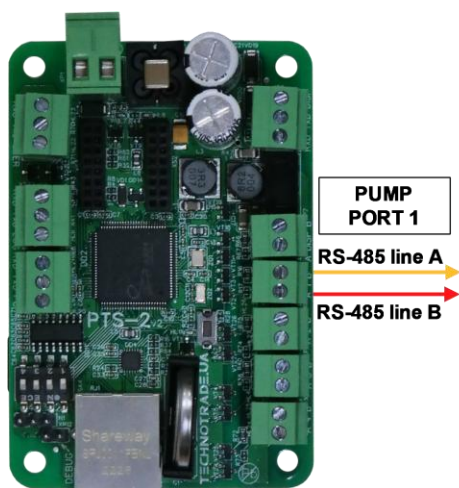

PTS-2 controller



Datian Machines dispenser interface board

Eaglestar dispenser connection scheme

Connection to Eaglestar dispenser is made directly without any interface converter.

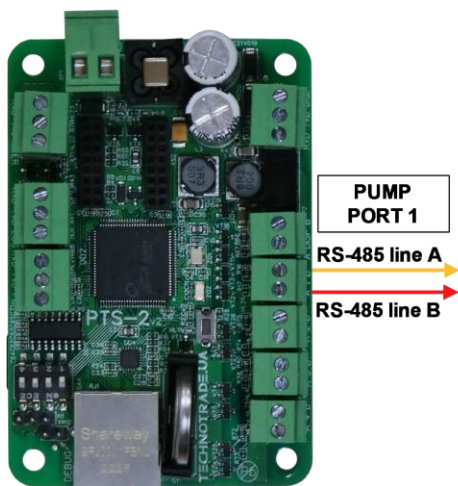

PTS-2 controller

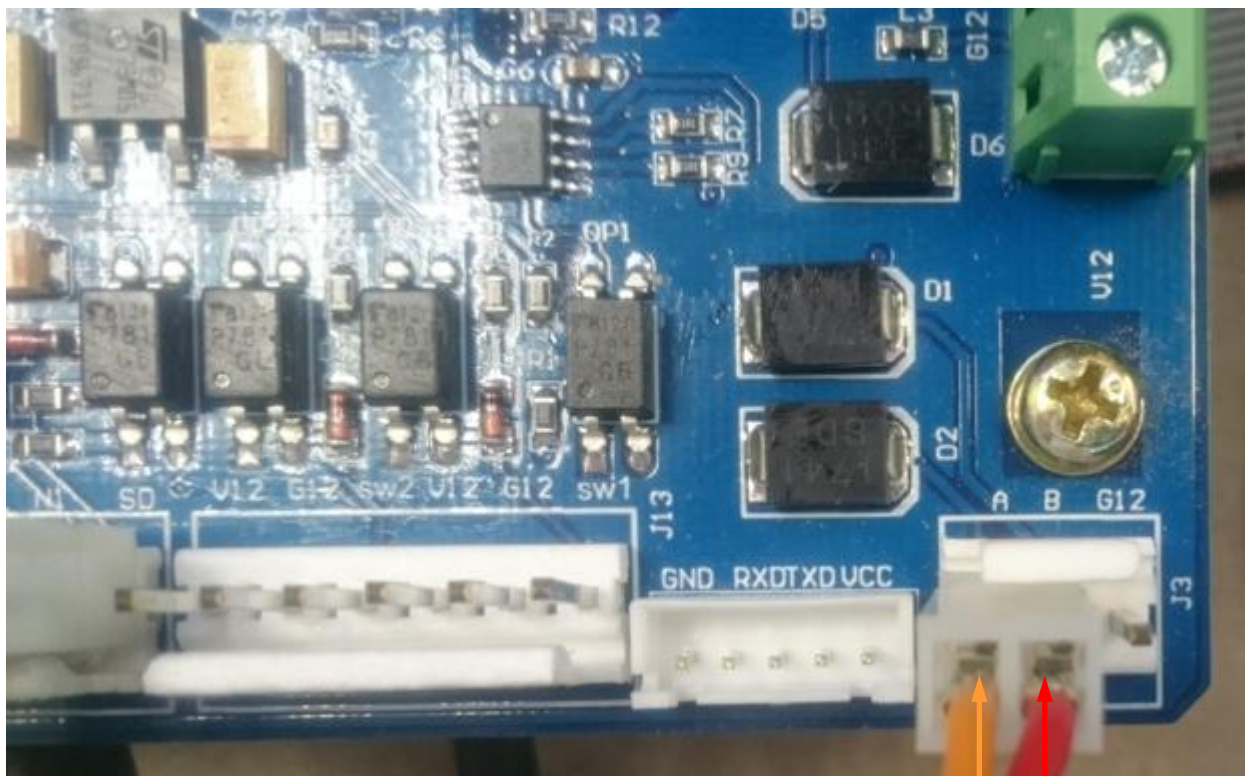

Eaglestar dispenser mainboard

Line A
Line B

Blue Sky dispenser connection scheme

Connection to Blue Sky dispenser is made directly without any interface converter.

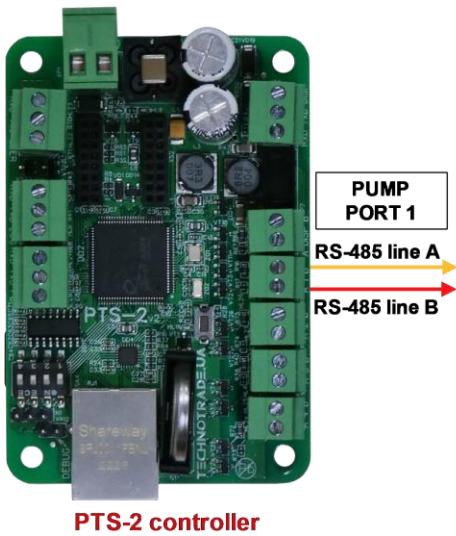

PTS-2 controller

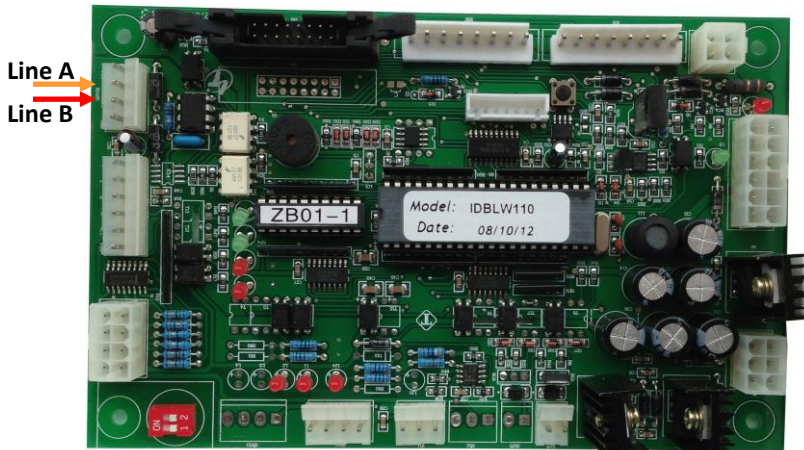

Blue Sky LT-B dispenser board

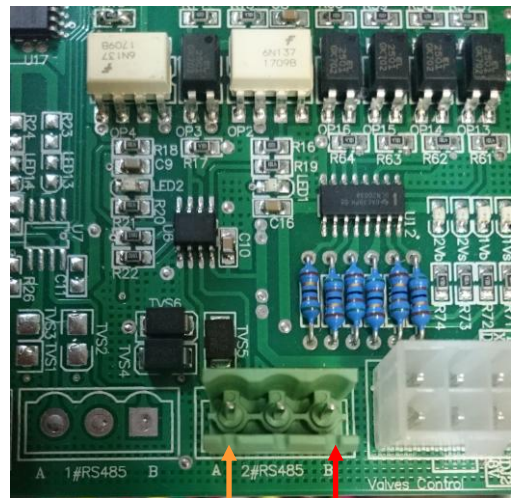

Blue Sky LT-LT-LG dispenser board

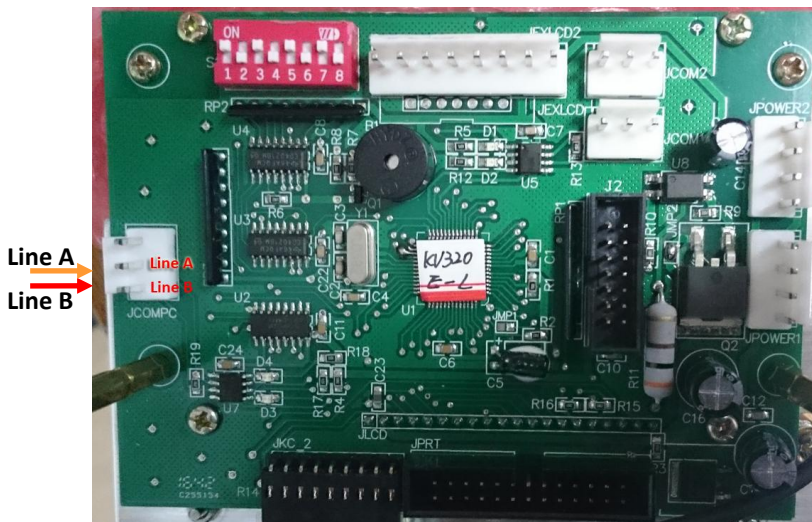

Blue Sky LT-C/LT-H dispenser board

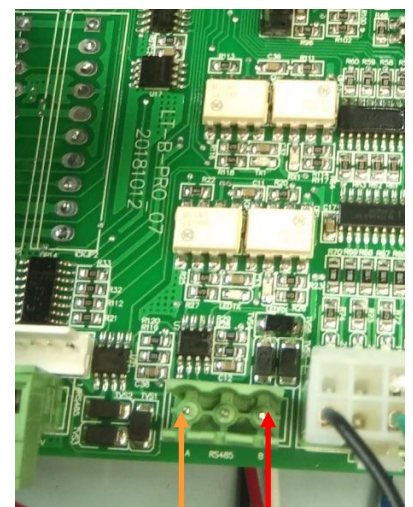

Blue Sky LT-B Pro dispenser board

Censtar dispenser connection scheme

Connection to Censtar dispenser can be made directly without any interface converter.

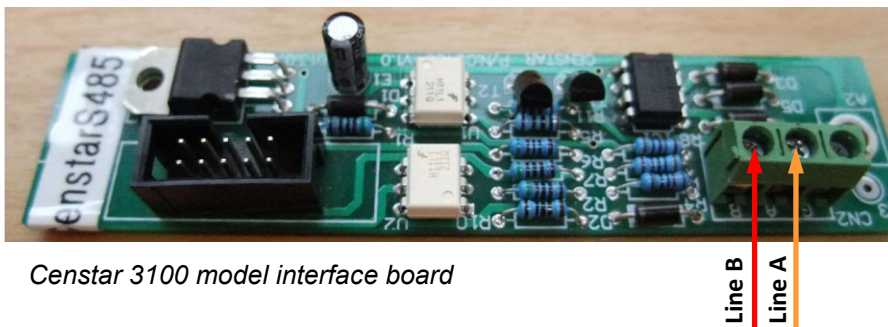
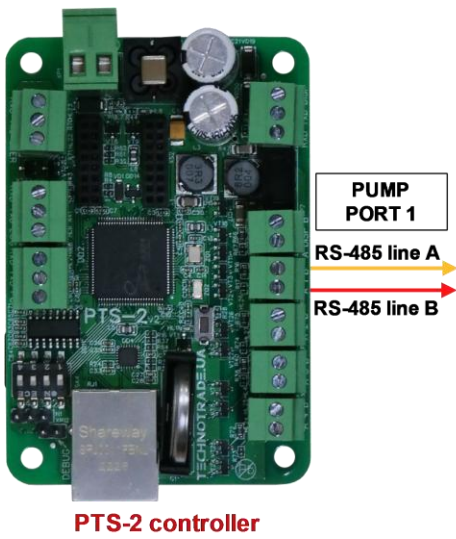

Knipflow dispenser connection scheme

Connection to Knipflow dispenser can be made directly without any interface converter.

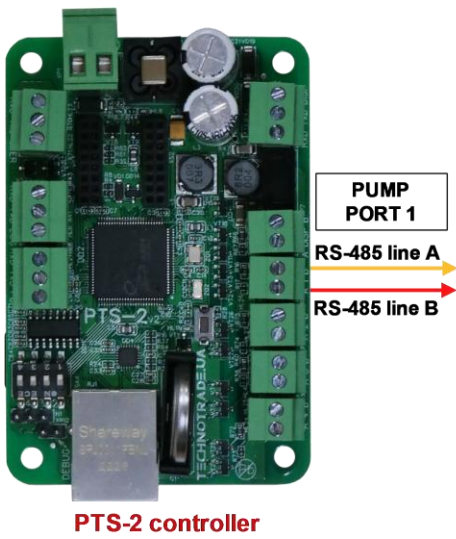

PTS-2 controller

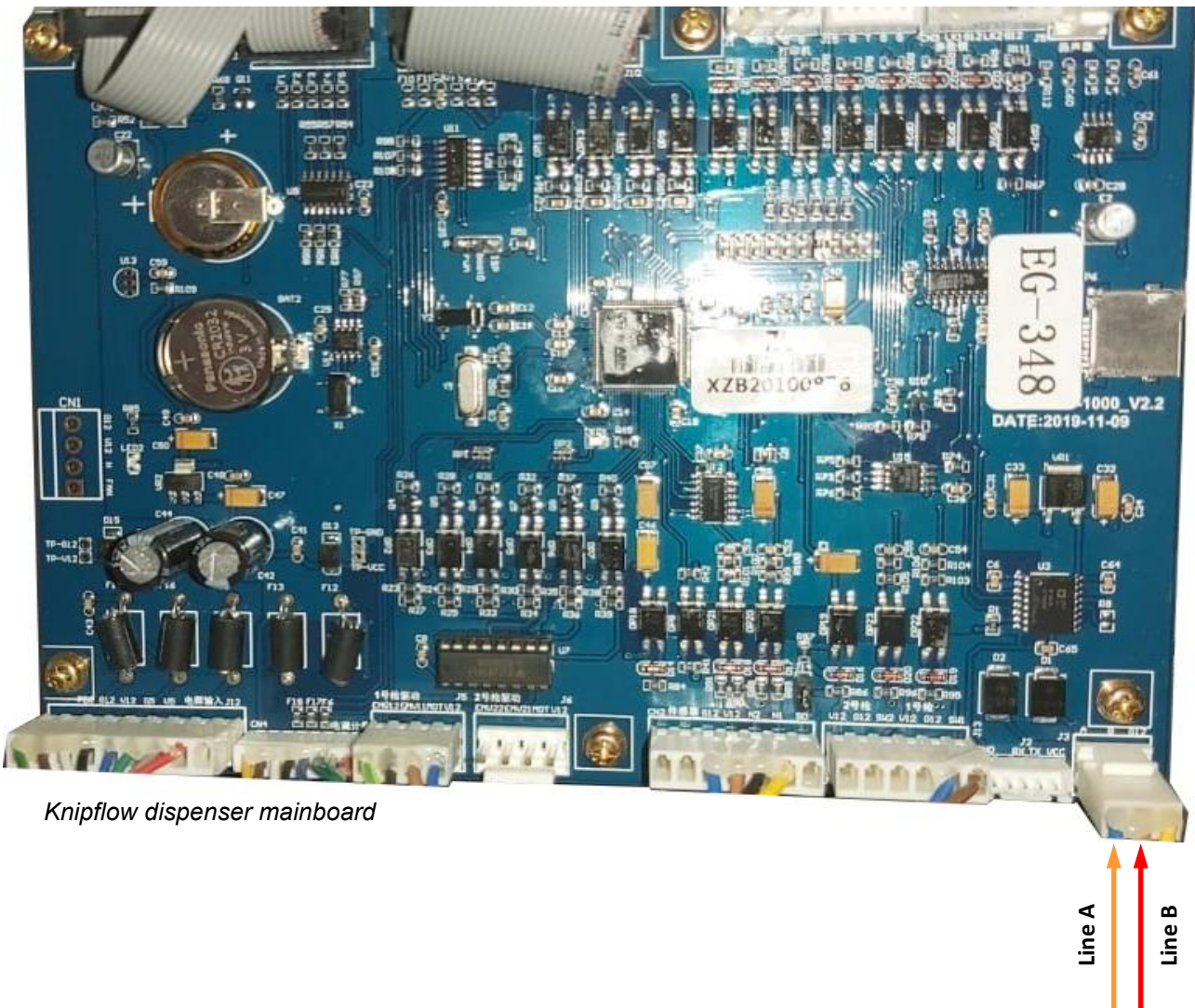

Knipflow dispenser mainboard

Line A
Line B

Changlong dispenser connection scheme

Connection to Changlong dispenser can be made directly without any interface converter.

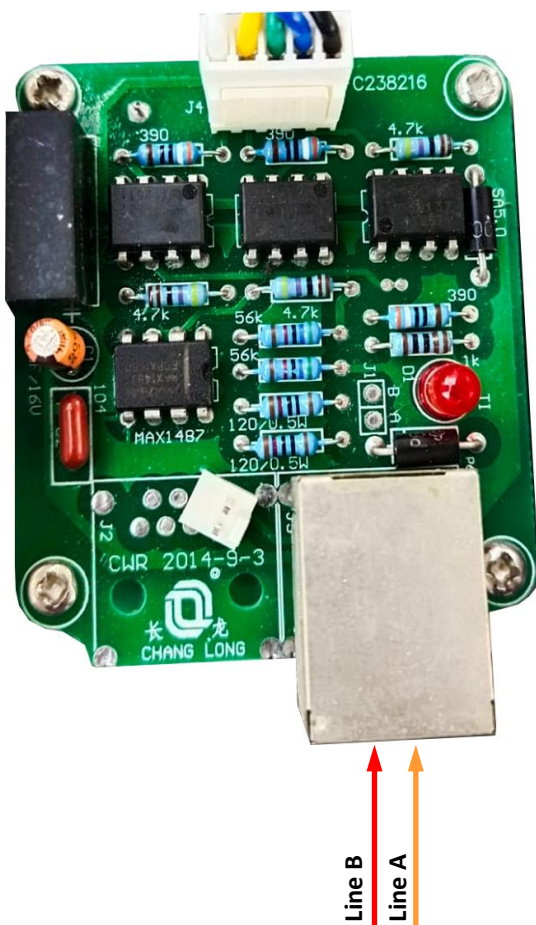
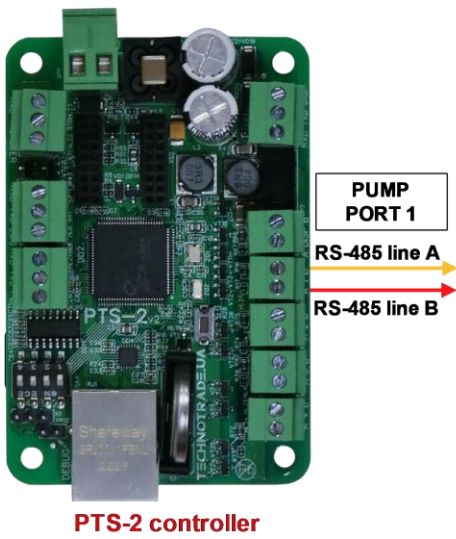

Zheng Genuine Machines dispenser connection scheme

Connection to Zheng Genuine Machines dispenser can be made directly without any interface converter.

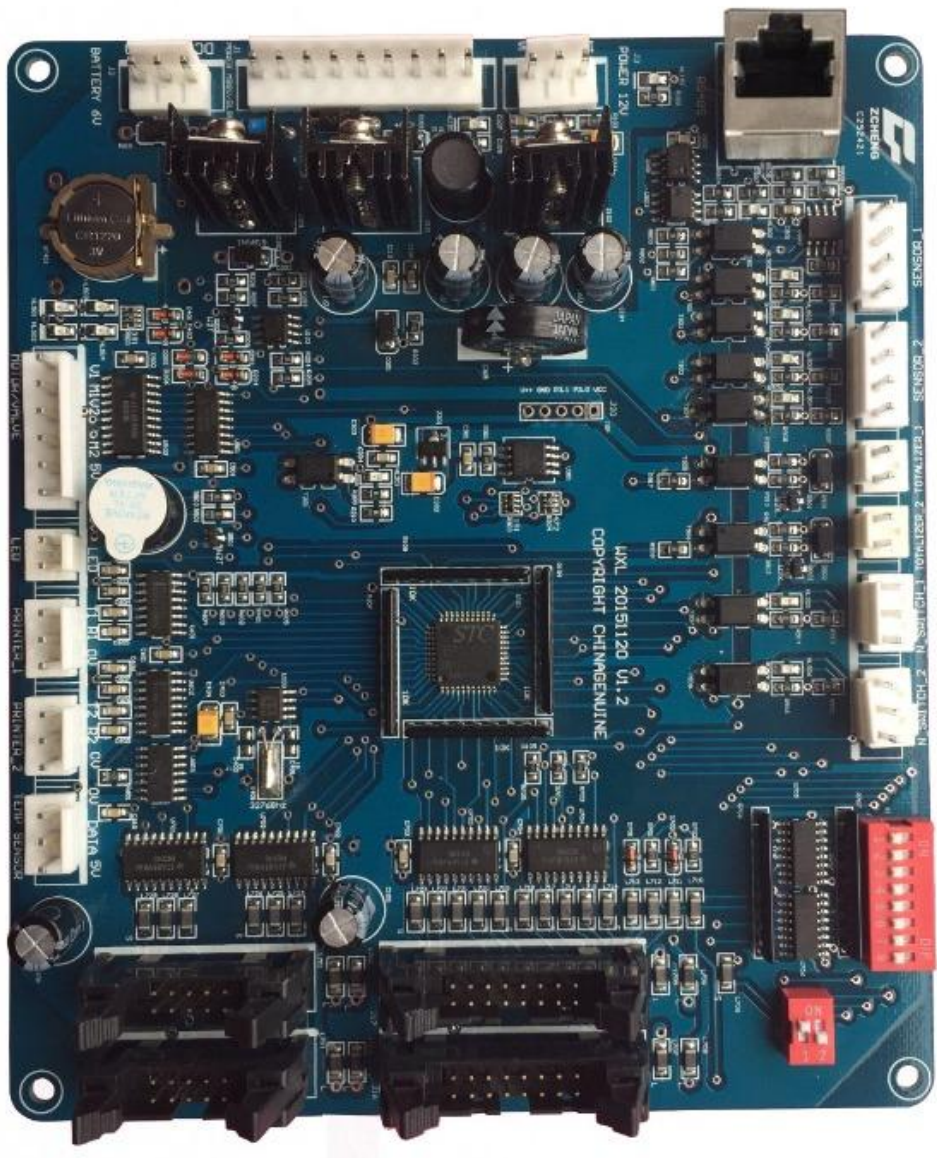
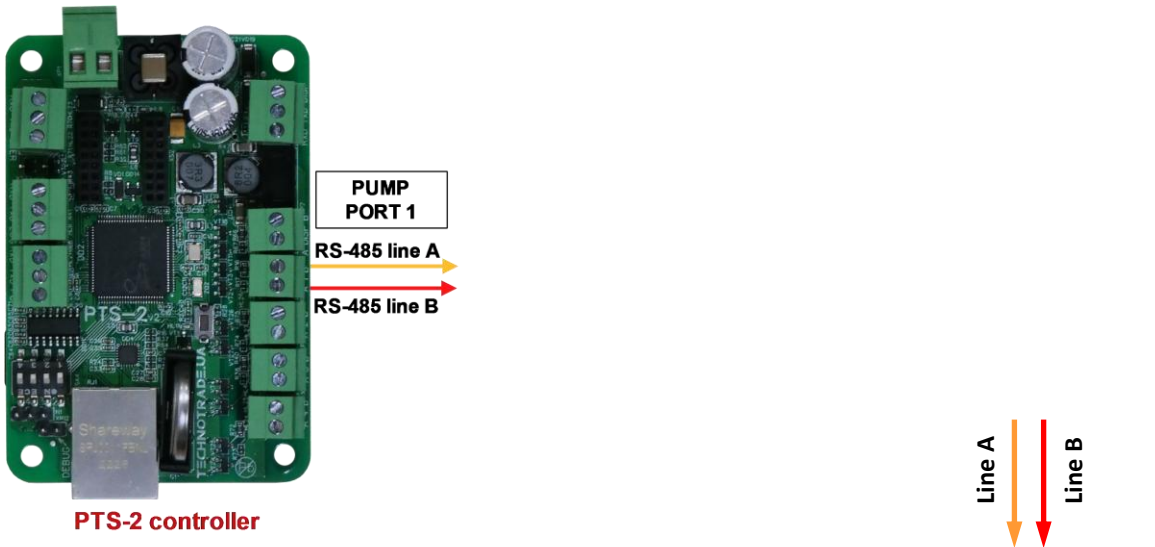

Zheng Genuine dispenser interface board

Bailong dispenser connection scheme

Connection to Bailong dispenser is made directly without any interface converter.

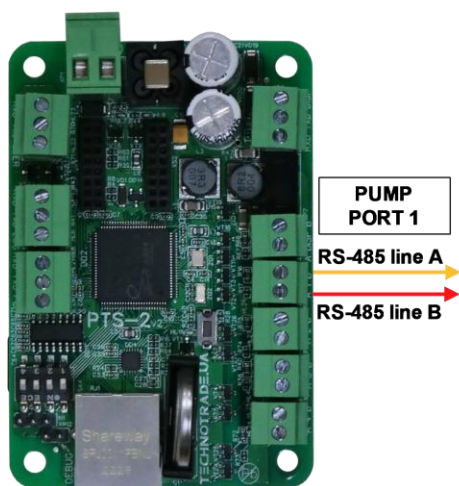

PTS-2 controller



Bailong dispenser board

Ecotec dispenser connection scheme

Connection to Ecotec dispenser can be made directly without any interface converter.

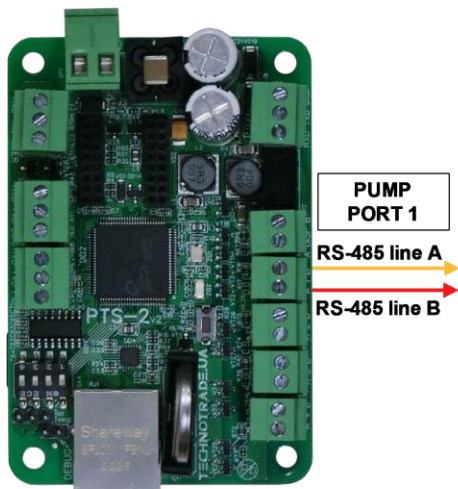

PTS-2 controller

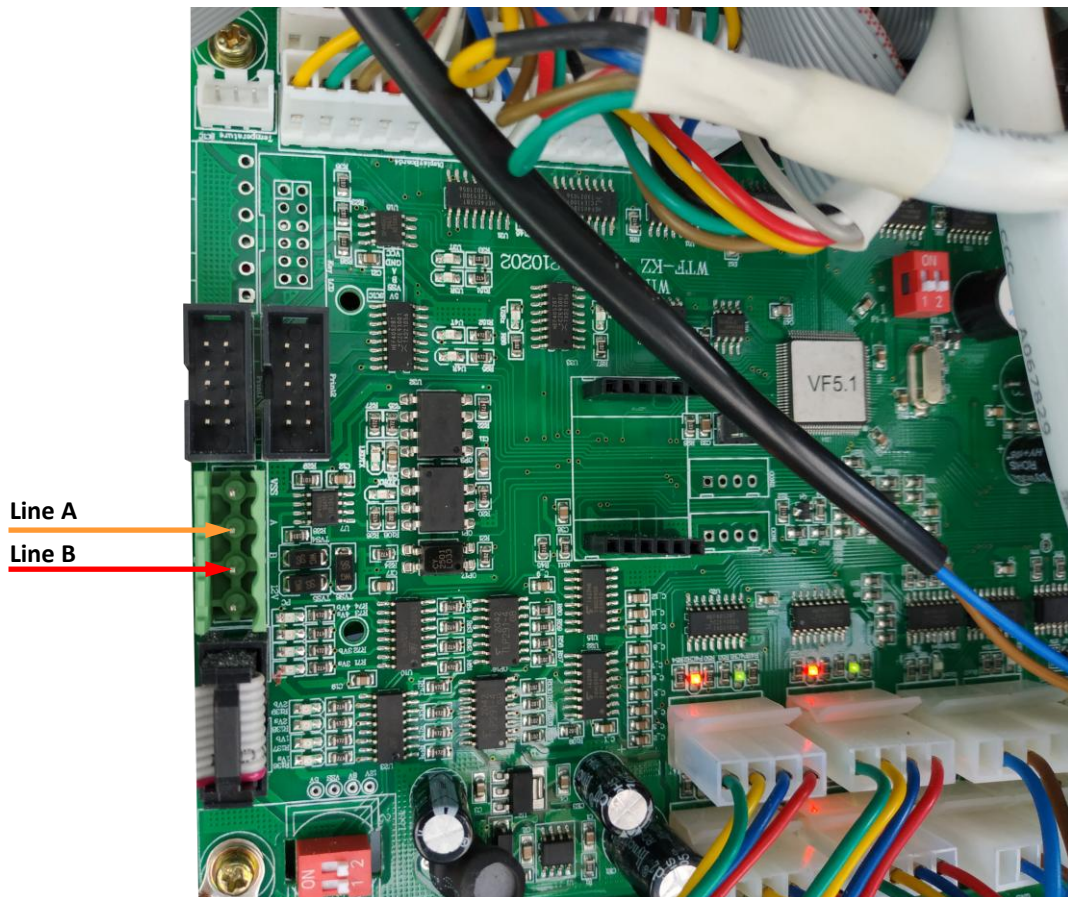

Topaz dispenser connection scheme

Connection to TOPAZ dispenser is made directly without any interface converter.

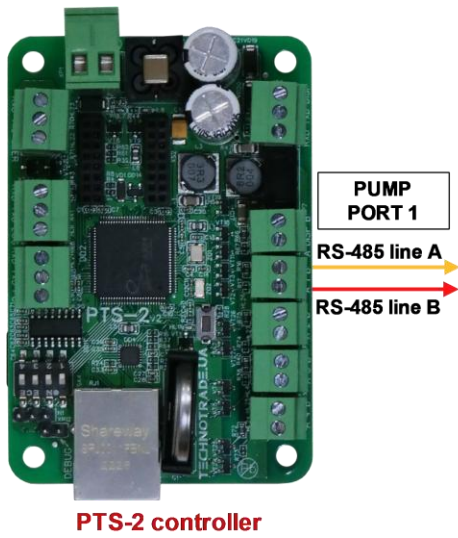

PTS-2 controller

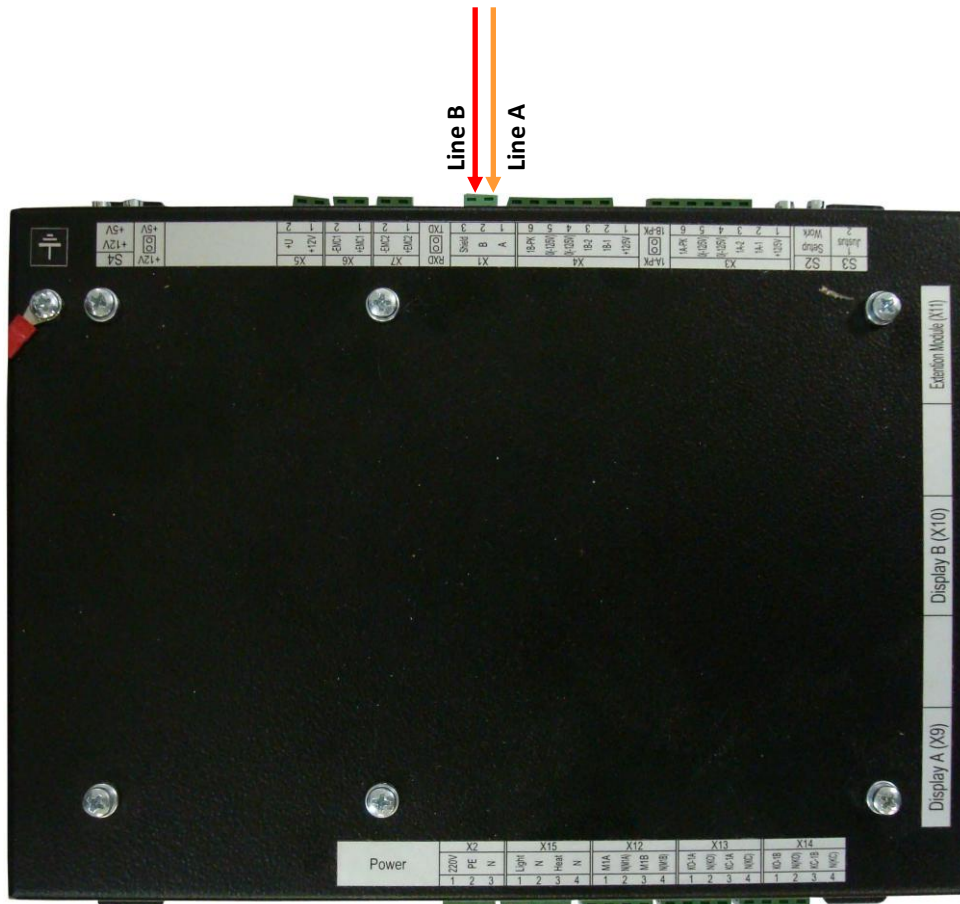

Topaz dispenser system board

Shelf dispenser connection scheme

Connection to SHELF dispenser is made directly without any interface converter.

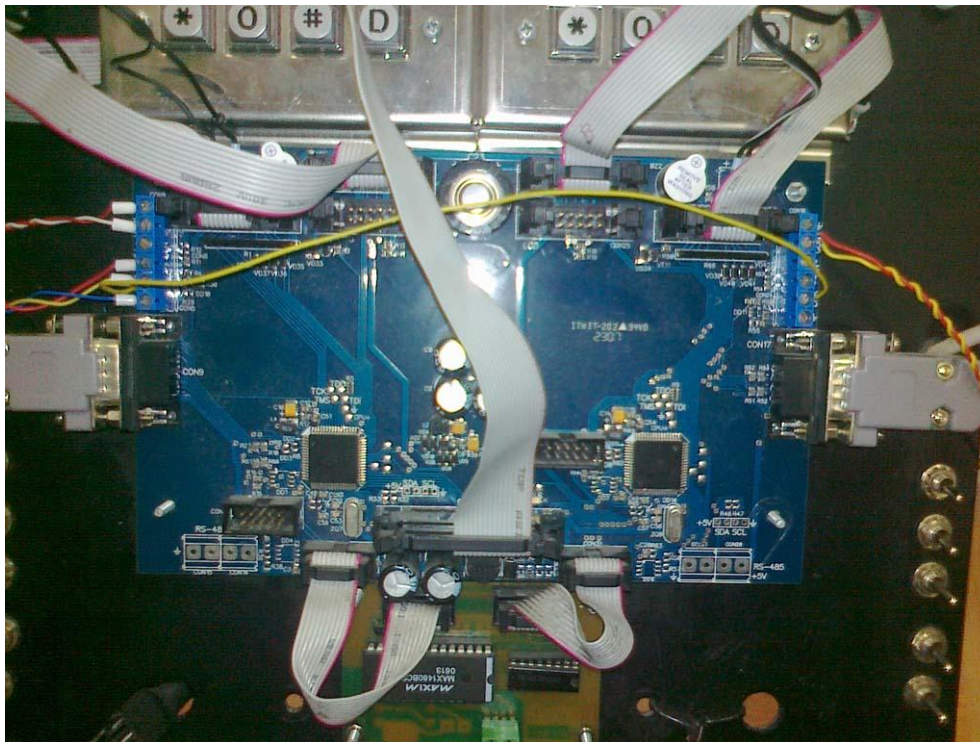
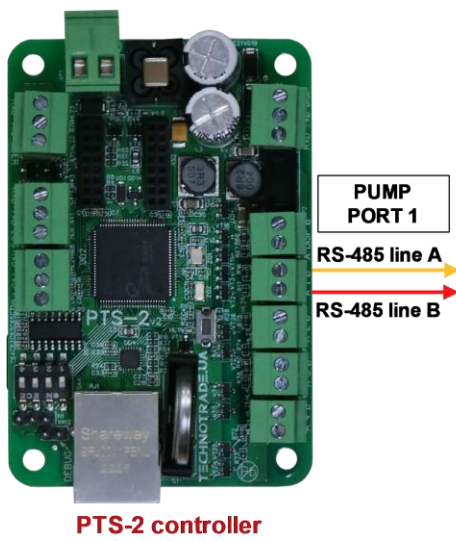

Shelf dispenser system board

Line A
Line B

UniCon dispenser connection scheme

Connection to UniCon dispenser is made directly without any interface converter.

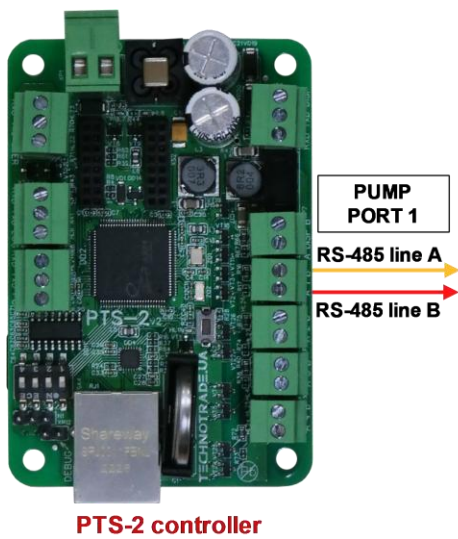

PTS-2 controller

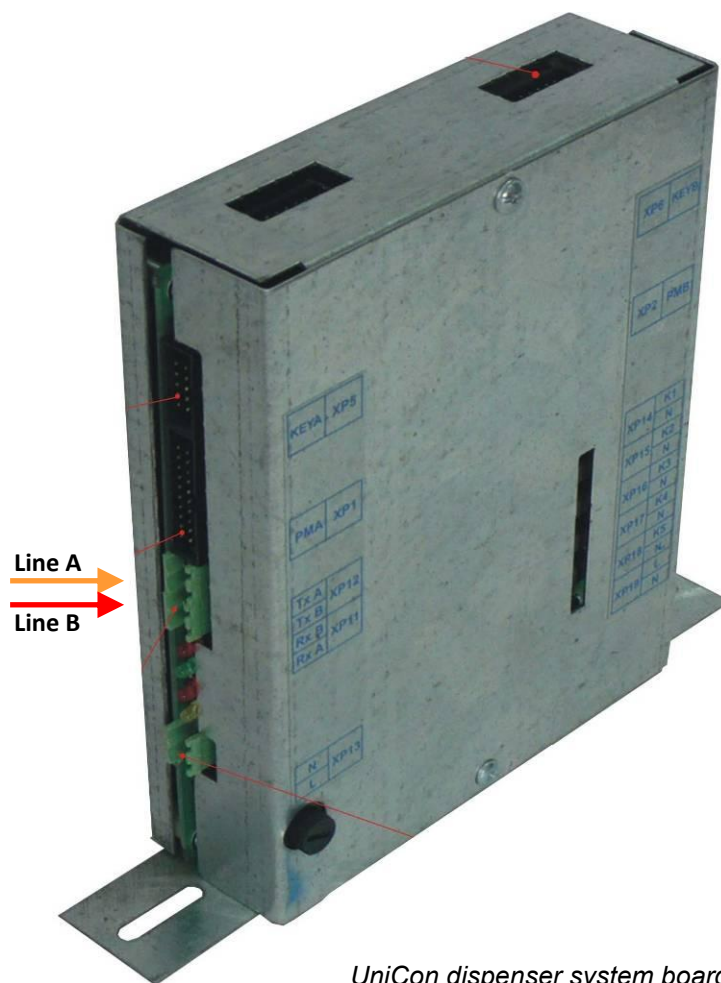

UniCon dispenser system board

Mechanical dispensers connection scheme

Connection to mechanical dispensers or to dispensers, which communication protocol is not supported, can be done through MC-4 controller over mechanical dispensers (<https://www.technotrade.ua/mechanical-controller.html>), which provides direct control over operation of electronic and mechanical fuel dispensers by controlling dispenser's internal resources: motor, pulse sensor, nozzle, slowdown valve..

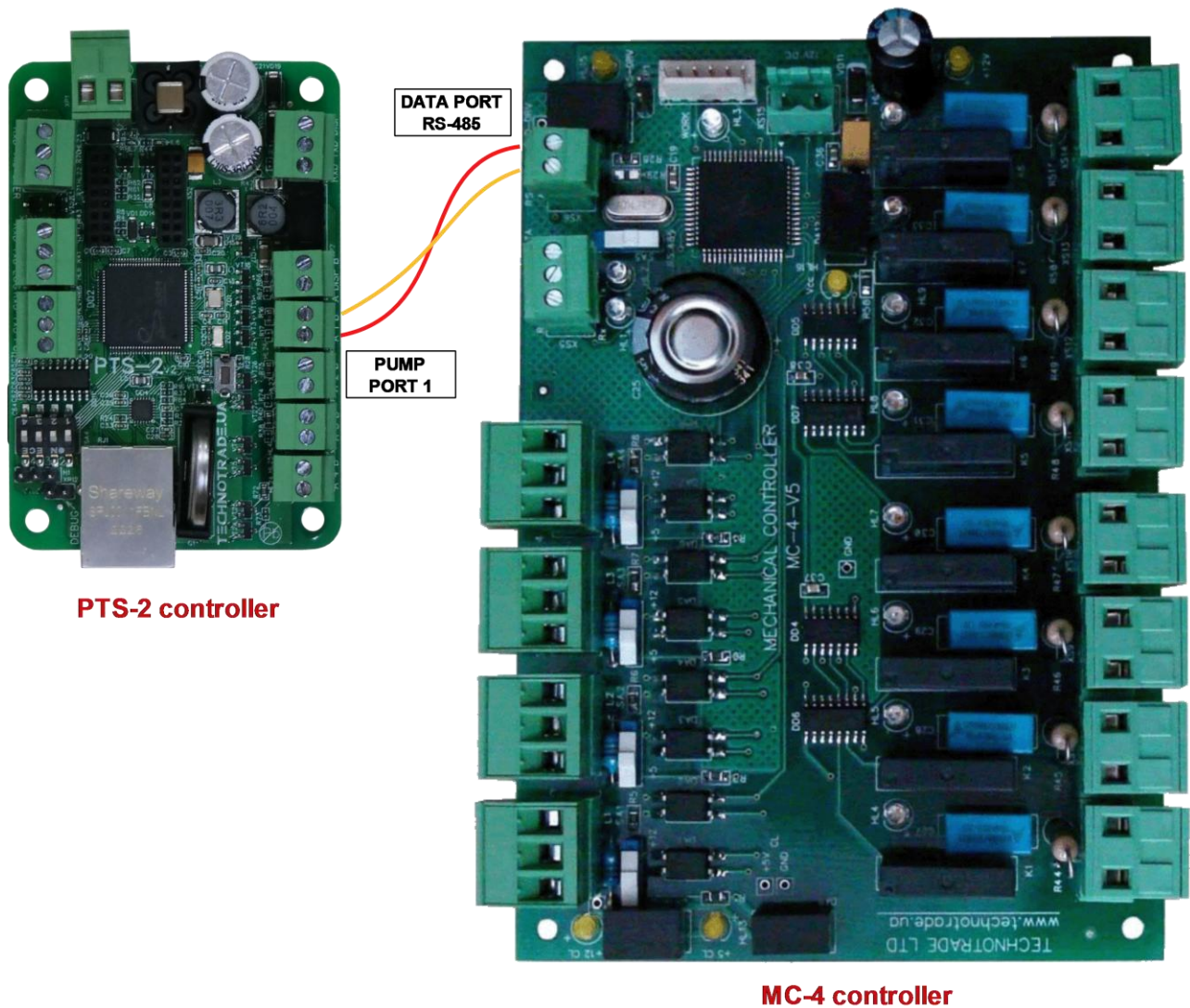

EXAMPLES OF CONNECTION TO ATG SYSTEMS

Below sections show examples of connection to various brands of probes and ATG systems. This information is provided as an example. For obtaining of detailed information on connection to various brands of ATG systems and probes, their configuration and configuration of PTS-2 controller please refer to our support page <https://www.technotrade.ua/support>.

Gilbarco Veeder Root TLS consoles connection scheme

Connection to Gilbarco Veeder Root TLS system is made directly to one of probe ports of PTS-2 controller (RS-232 interface).

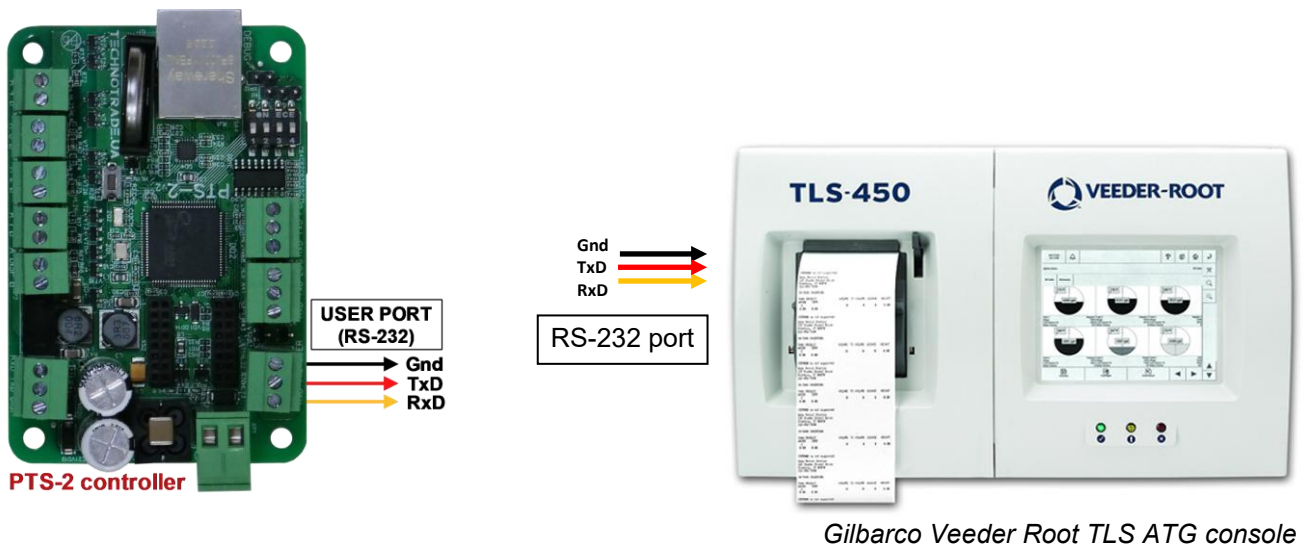

Start Italiana console connection scheme

Connection to Start Italiana console is made directly to one of probe ports of PTS-2 controller (RS-232 interface).

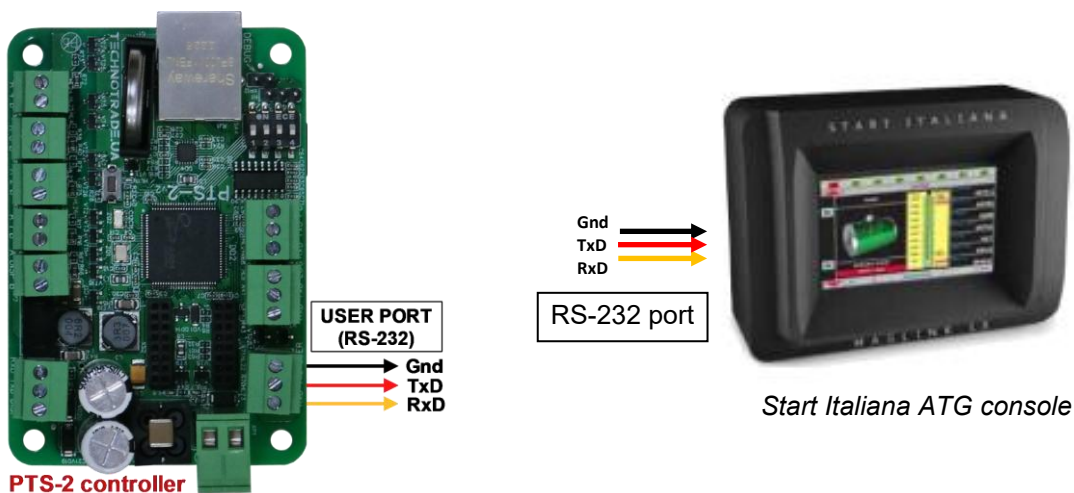

Start Italiana wired probes connection scheme

Connection to Start Italiana wired probes is made directly to DISP (RS-485) port of PTS-2 controller (RS-485 interface) (connection is made through an intrinsic safety barrier).

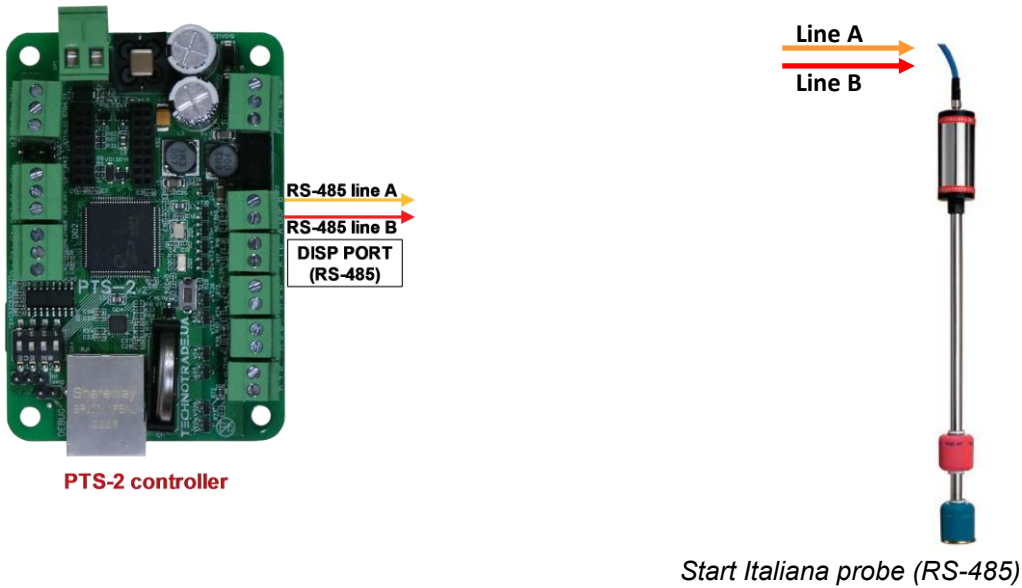

Start Italiana wireless probes connection scheme

Connection to Start Italiana wireless probes is made through wireless receiver to one of probe ports of PTS-2 controller (RS-232 interface or RS-485 interface).

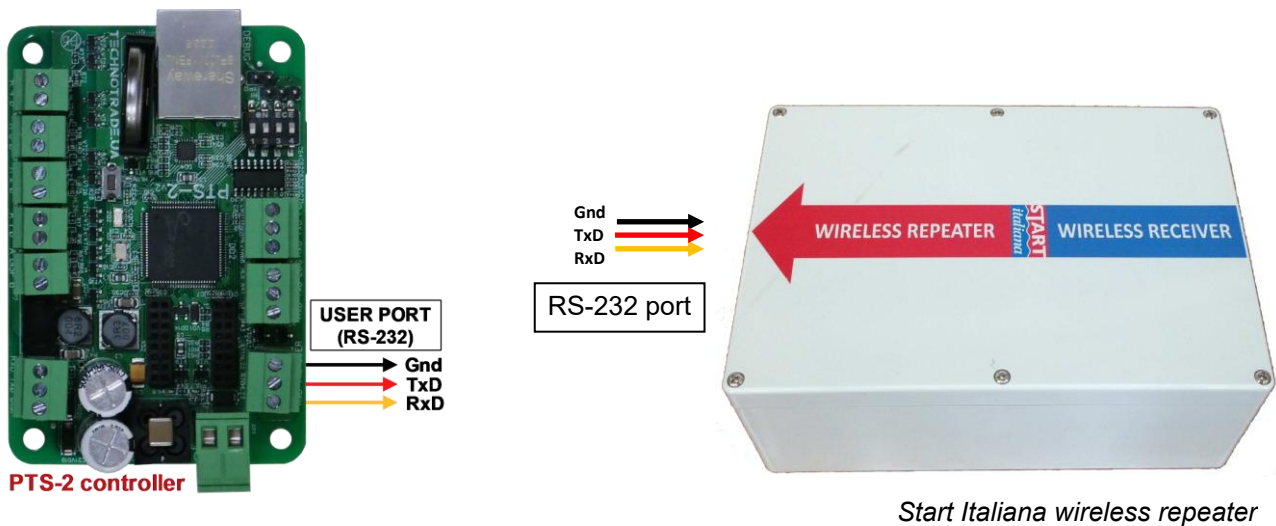

Alisonic wired probes connection scheme

Connection to Alisonic wired probes is made directly to DISP (RS-485) port of PTS-2 controller (RS-485 interface) (connection is made through an intrinsic safety barrier).

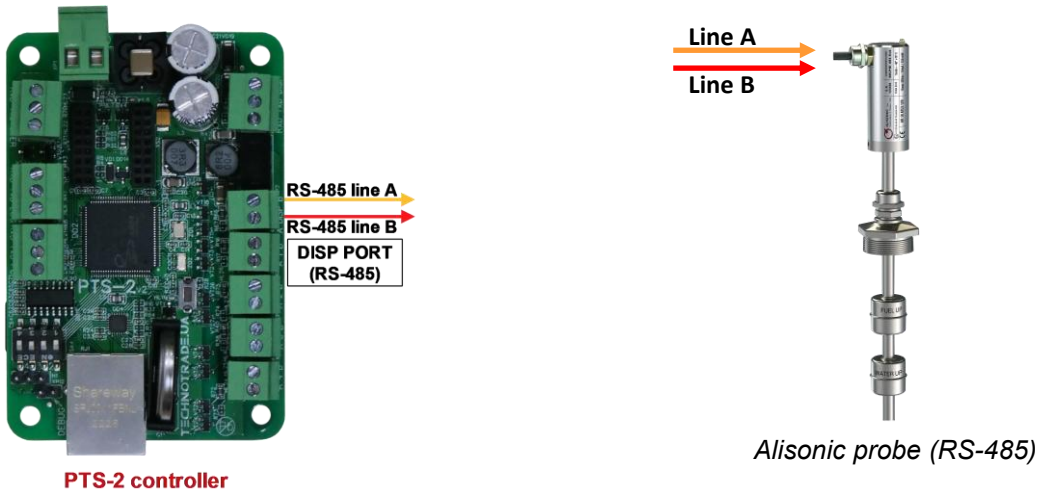

Alisonic wireless probes connection scheme

Connection to Alisonic wireless probes is made through Alisonic wireless receiver to DISP (RS-485) port of PTS-2 controller (RS-485 interface).

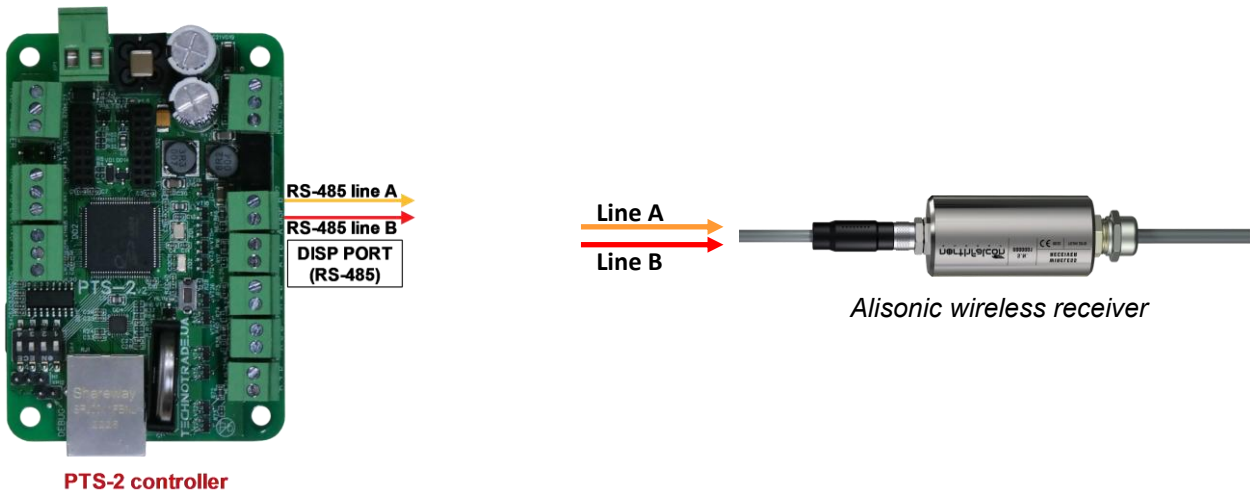

Struna ATG system connection scheme

Connection to Struna system is made directly to one of probe ports of PTS-2 controller (RS-232 interface).

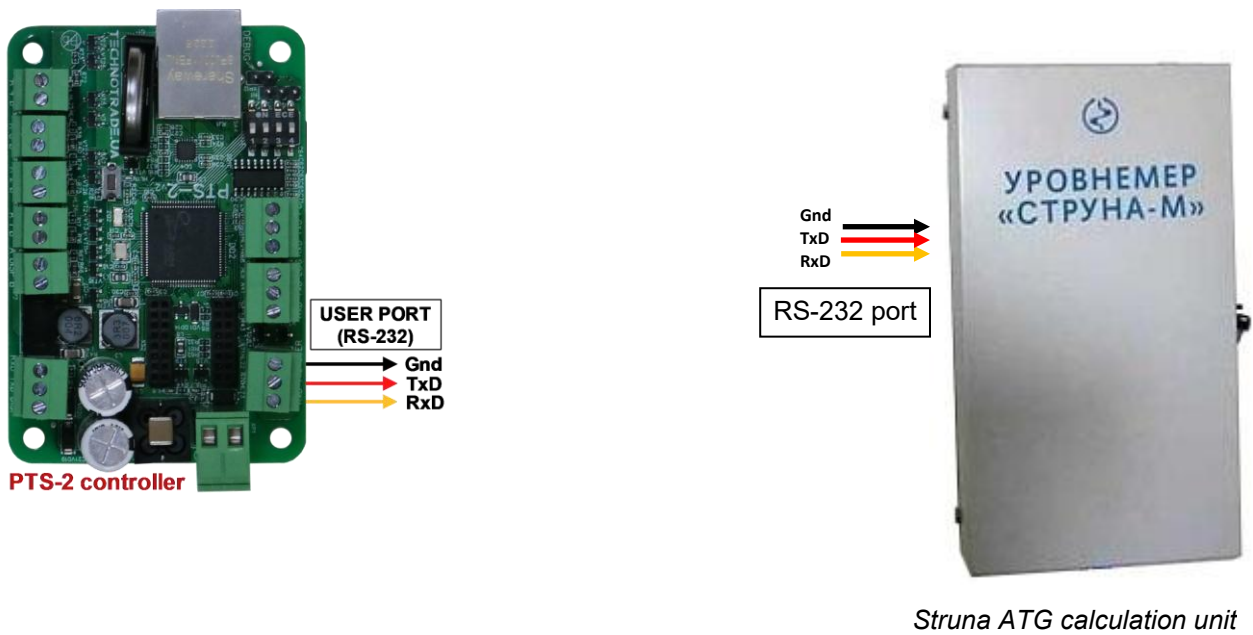

OPW Site Sentinel ATG system connection scheme

Connection to OPW system is made directly to one of probe ports of PTS-2 controller (RS-232 interface).

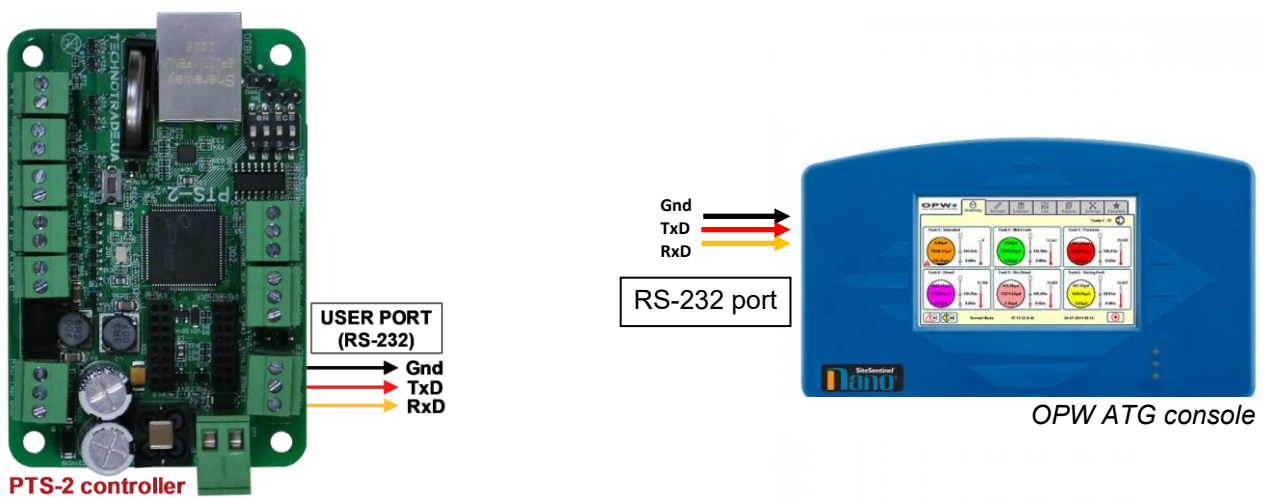

Colibri ATG system connection scheme

Connection to Colibri system is made directly to one of probe ports of PTS-2 controller (RS-232 interface).

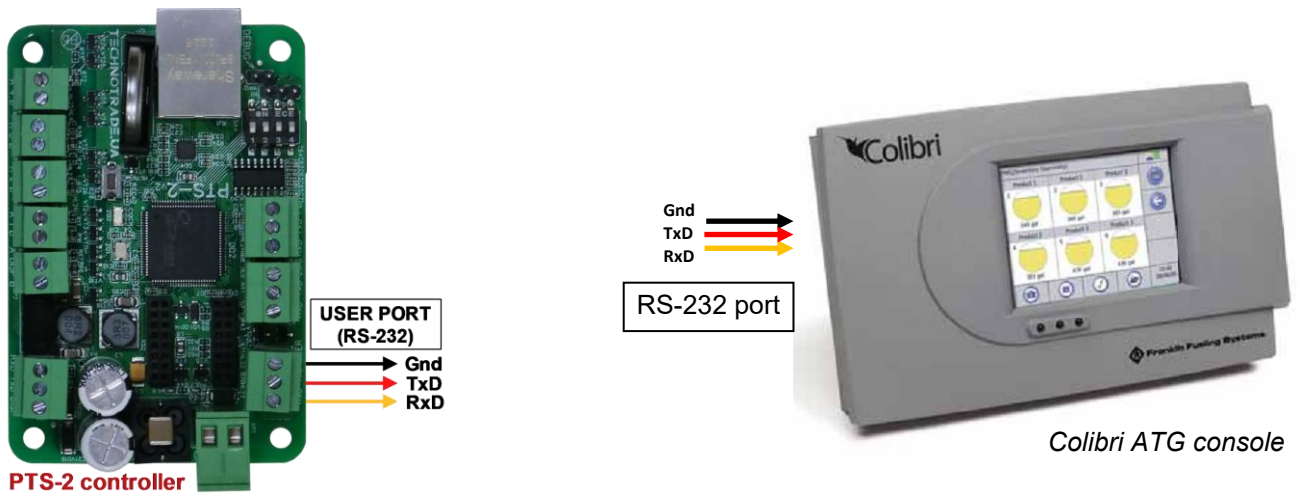

Fafnir ATG system connection scheme

Connection to FAFNIR system is made directly to one of probe ports of PTS-2 controller (RS-232 interface).

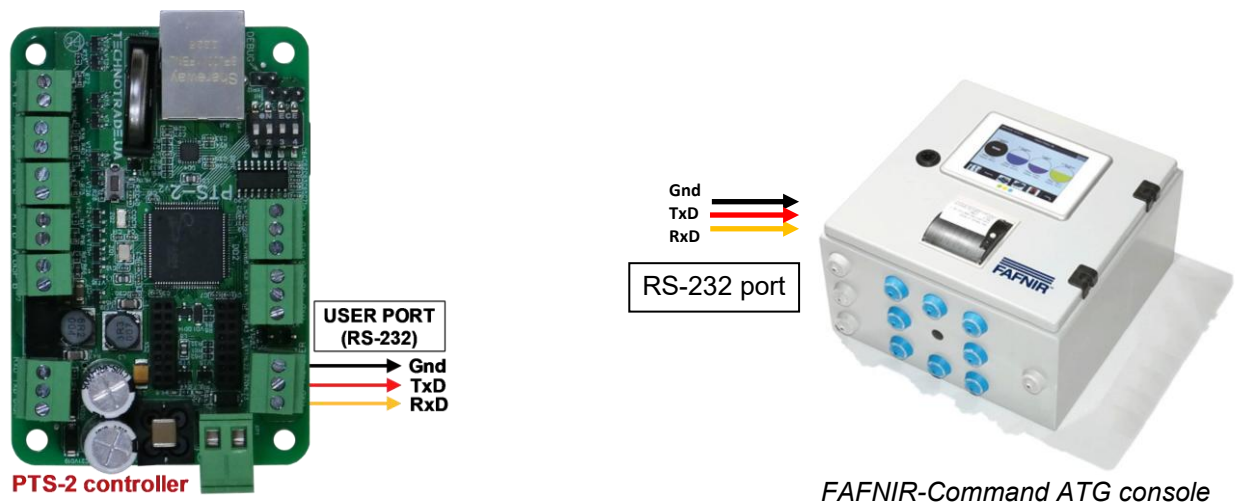

Hectronic ATG probes connection scheme

Connection to Hectronic probes is made directly to one of probe ports of PTS-2 controller (RS-232 interface) to Hectronic OptiLevel Supply box.

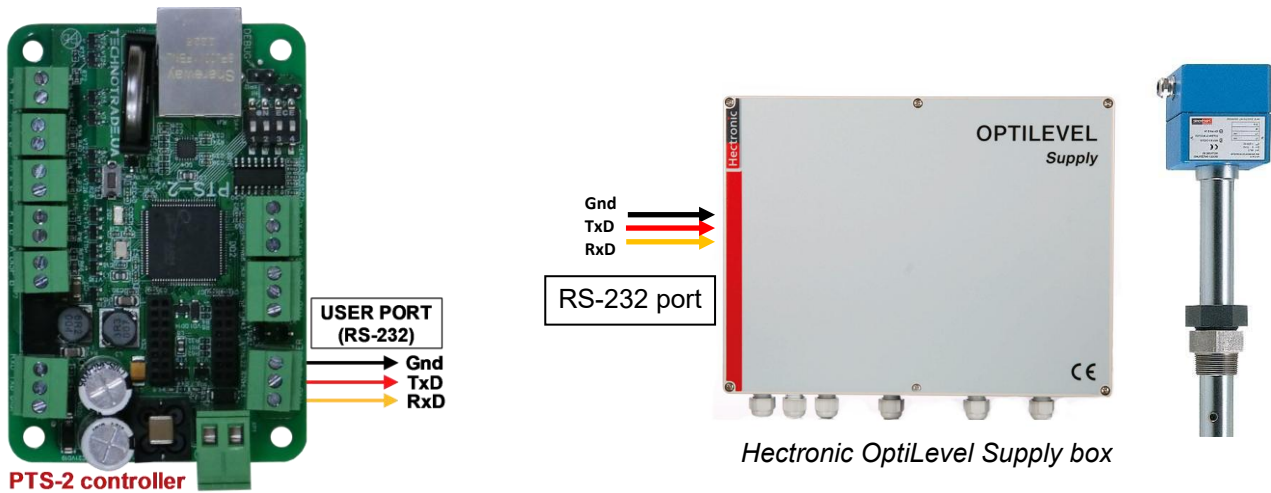

Vega radar level meters

Connection to VEGA meters is made through a VEGAMET box is made directly to one of probe ports of PTS-2 controller (RS-232 interface).

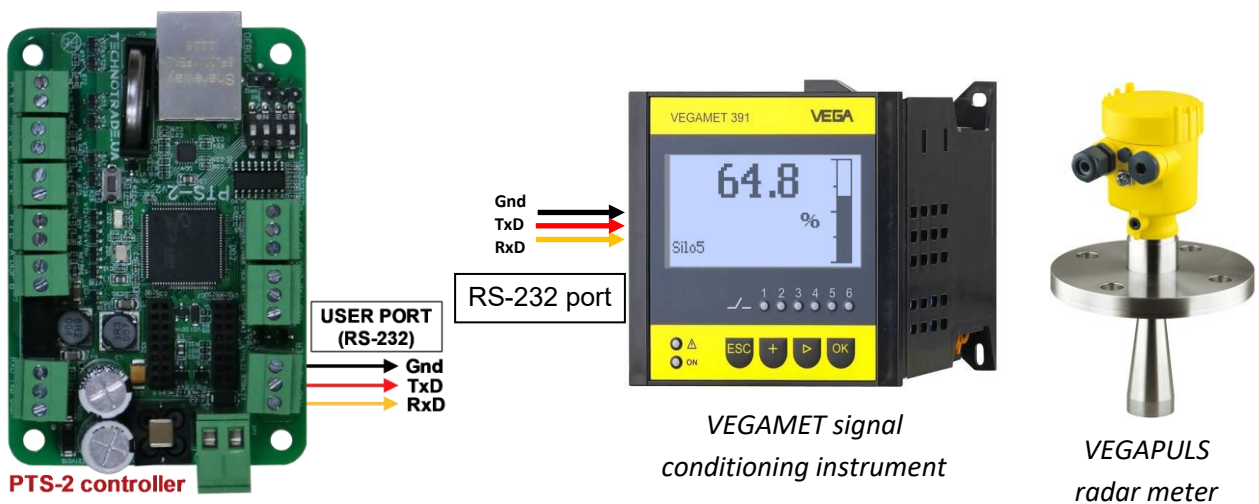

Windbell magnetostrictive probes connection scheme

Connection to Windbell probes is made directly to DISP (RS-485) port of PTS-2 controller (RS-485 interface) (connection is made through an intrinsic safety barrier).



PTS-2 controller

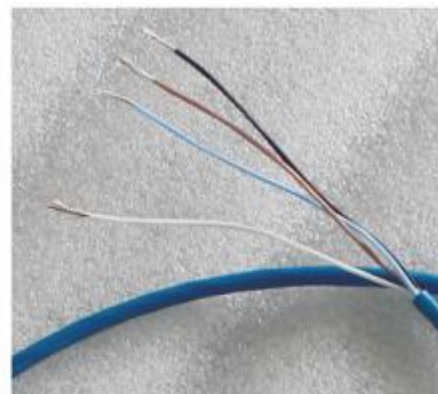
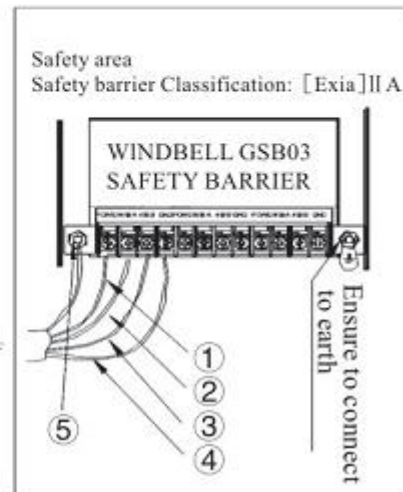
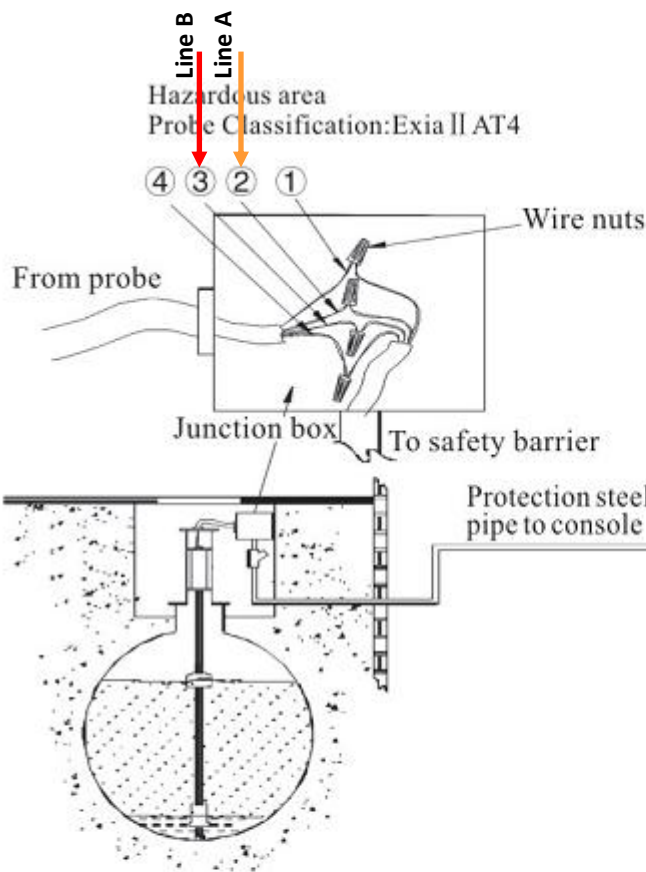
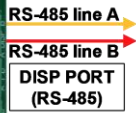

No.	Power wires	Port of safety barrier
①	Blue wire	Power (Power +)
②	Brown wire	485A
③	White wire	485B
④	Black wire	GND (Power-)
⑤	Shielded wire	

North Falcon wired probes connection scheme

Connection to North Falcon wired probes is made directly to DISP (RS-485) port of PTS-2 controller (RS-485 interface) (connection is made through an intrinsic safety barrier).

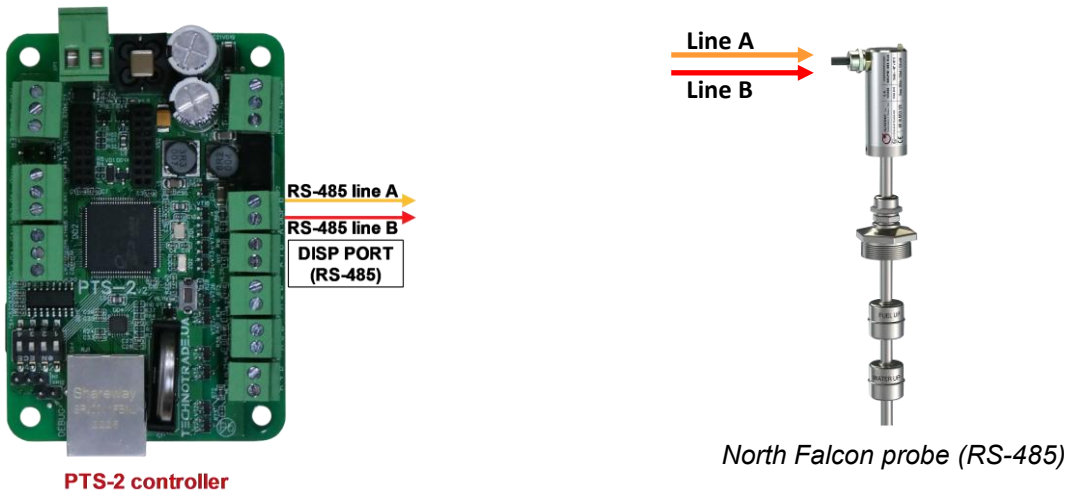

North Falcon wireless probes connection scheme

Connection to North Falcon wireless probes is made through North Falcon wireless receiver to DISP (RS-485) port of PTS-2 controller (RS-485 interface).

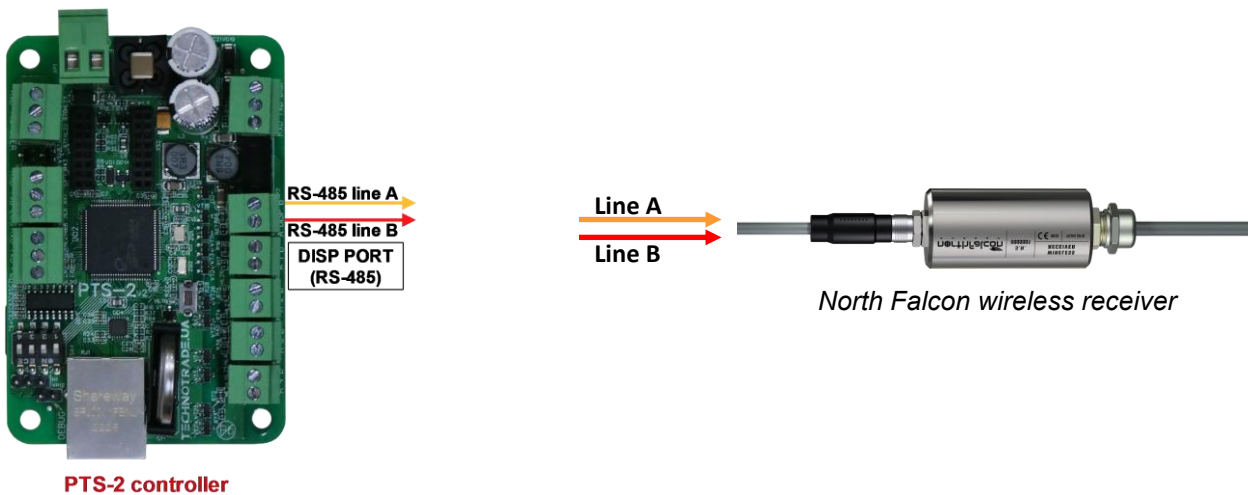

EXAMPLES OF CONNECTION TO PRICE POLES

Below sections show examples of connection to various brands of price poles. This information is provided as an example. For obtaining of detailed information on connection to various brands of price poles, their configuration and configuration of PTS-2 controller please refer to our support page <https://www.technotrade.ua/support>.

PWM price poles connection scheme

Connection to PWM price poles is made directly to DISP (RS-485) port of PTS-2 controller (RS-485 interface).

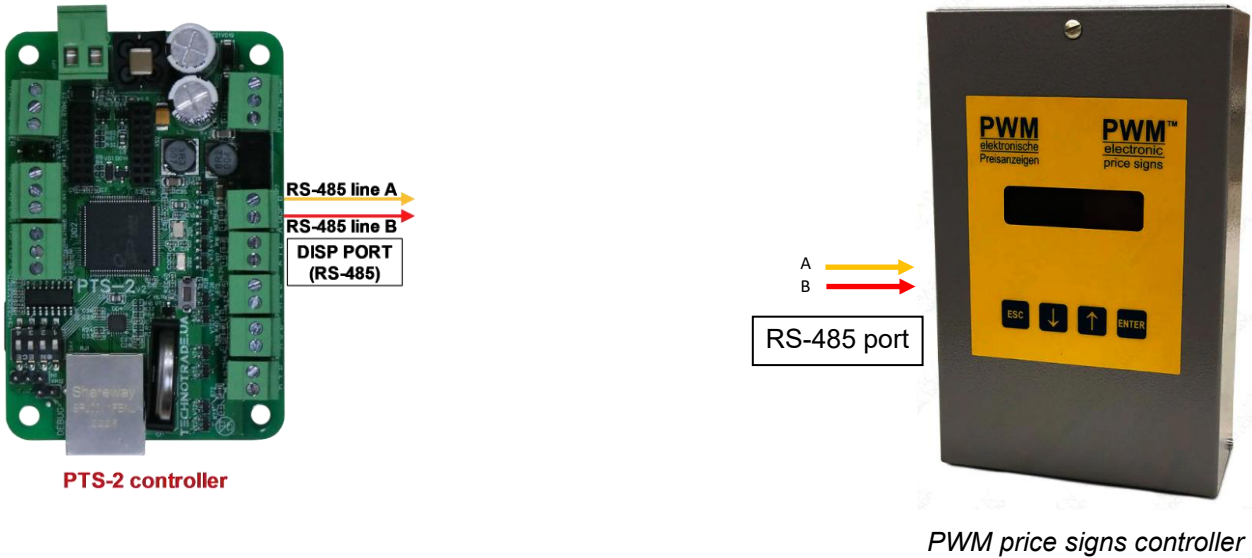

BEVER Innovations price signs connection scheme

Connection to BEVER Innovations price sign is made directly to DISP (RS-485) port of PTS-2 controller (RS-485 interface).

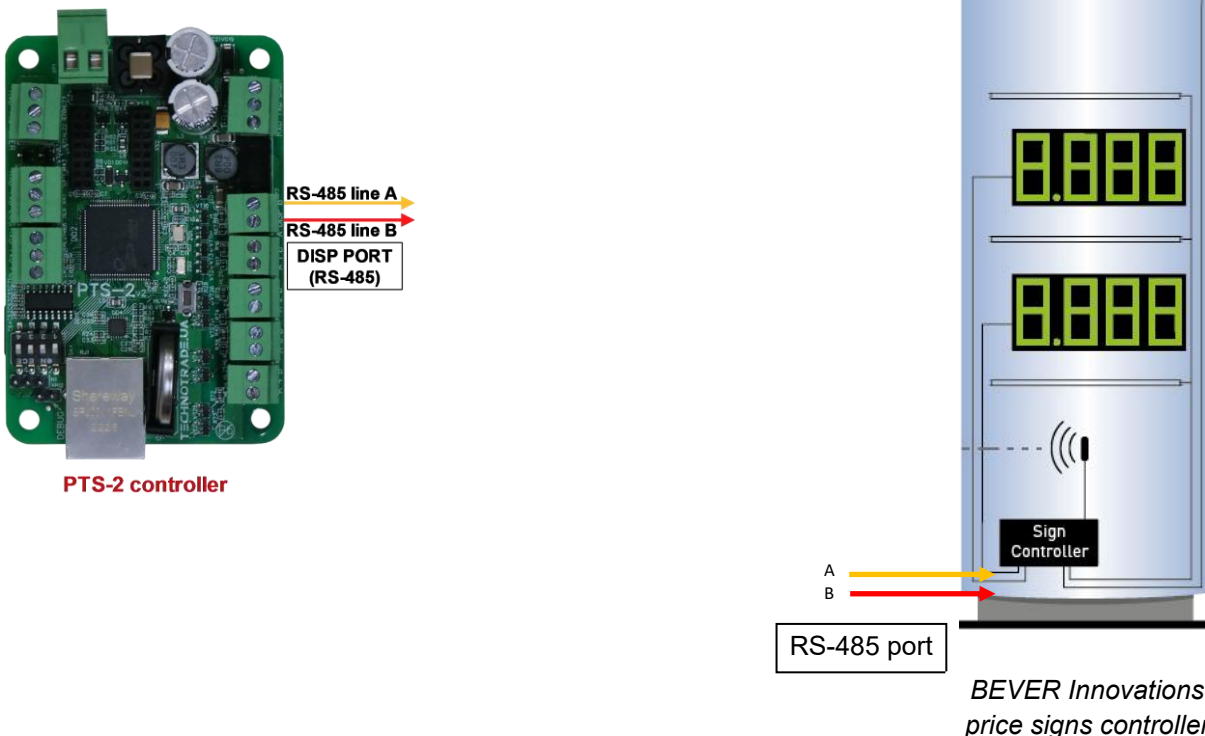

EXAMPLES OF CONNECTION TO READERS AND AVI SYSTEMS

Below sections show examples of connection to various brands of readers and AVI (automatic vehicles identification) systems. This information is provided as an example. For obtaining of detailed information on connection to various brands of readers and AVI systems, their configuration and configuration of PTS-2 controller please refer to our support page <https://www.technotrade.ua/support>.

VRD-485 RFID readers connection scheme

Connection to VRD-485 RFID readers installed on dispensers is made directly to DISP (RS-485) port of PTS-2 controller (RS-485 interface).

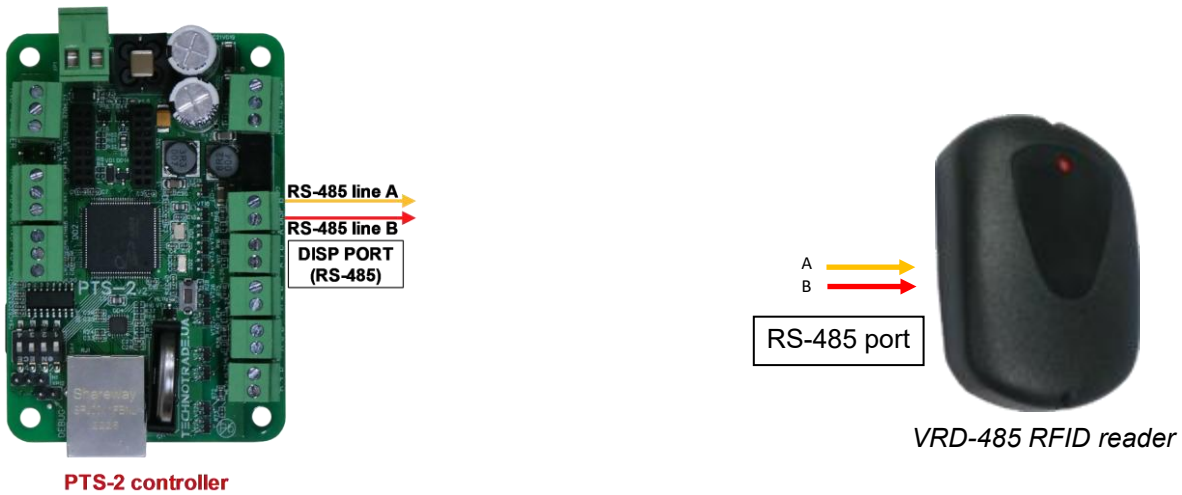

MINGTE AVI system controller connection scheme

Connection to MINGTE AVI system controller is directly to one of probe ports of PTS-2 controller (RS-232 interface).

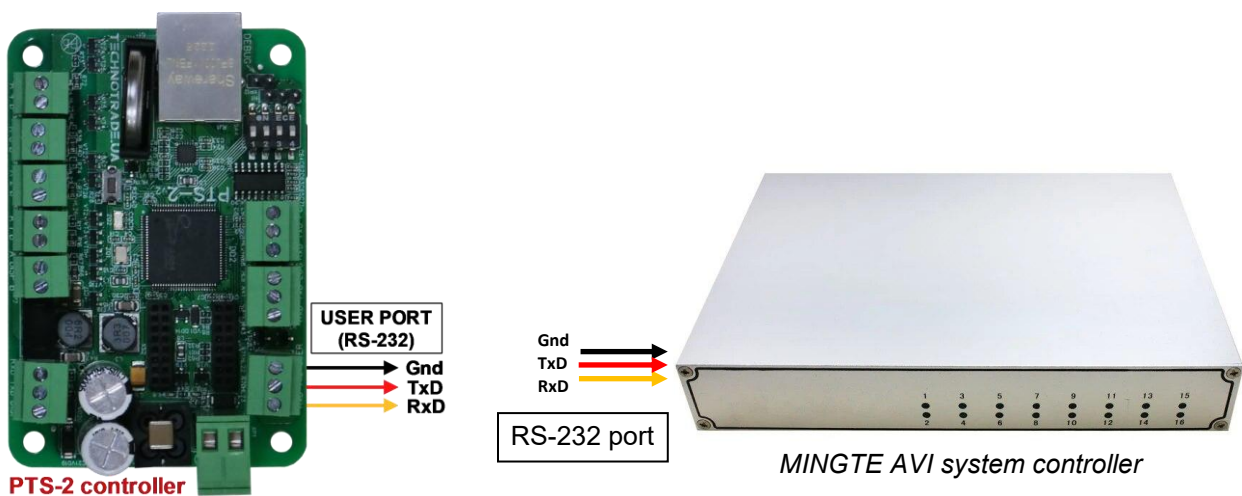

ORDER INFORMATION

Variant of PTS-2 controller supply is marked with *PTS2-y-z*, where

- U – version of PTS-2 controller electric board;
- y – type of supply:
 - “PCB” in case if PTS-2 controller is supplied in a view of electric board;
 - “BOX” in case if PTS-2 controller is supplied installed in mounting box with hermetic inputs for connection of wires and a button for power supply switching;
 - “SDK” in case of PTS-2 controller SDK is supplied installed in mounting box with hermetic inputs for connection of wires and a button for power supply switching;
- z – variant of supply:
 - 001 – variant of supply with installed terminal blocks for controller ports

Examples of order:

- order of PTS-2 controller in a view of electric board: PTS2-PCB-001
- order of PTS-2 controller installed in a mounting box: PTS2-BOX-001
- order of PTS-2 controller SDK: PTS2-SDK-001